

Gynäkologie

Gynecology

Laparoscopy, Pelviscopy

Laparoskopie, Pelviskopie

Hysterectomy

Hysterektomy

*Diagnostic and operative
Hysteroscopy*

Diagnostische und operative
Hysteroskopie

Interdisciplinary Applications

Interdisziplinäre Anwendungen



Laparoskopie

Laparoscopy

Laparoscopy

Laparoskopie

1

Basic Sets

Basis-Sets

2

Telescopes

Optiken

3

*Trocar Sleeves / Dilatation / Extraction /
Reducing Sleeves*

Trokarhülsen / Dilatation / Extraktion /
Reduzierhülsen

4

Grasping Forceps / Dissectors / Biopsy Forceps

Greifzangen / Dissektoren / PE-Zangen

5

Scissors

Scheren

6

Bipolar Forceps and Scissors

Bipolare Zangen und Scheren

7

HF Electrodes (monopolar / bipolar)

HF-Elektroden (monopolar / bipolar)

8

*Suction and Irrigation Tubes /
Multifunction Instruments*

Saug-und Spülrohre /
Multifunktions-Instrumente

9

Retractors / Holding Arm Systems

Retraktoren / Haltearm-Systeme

10

Applicators / Tissue Clamps

Applikatoren / Gewebeklemmen

11

Needle Holder / Knot Pusher / Fascia Closure

Nadelhalter / Knotenschieber / Faszienverschluss

12

Cannulas / Probes / Myoma Screw

Kanülen / Taststäbe / Myombohrer

13

Bariatric Surgery

Adipositas-Chirurgie

14

Units / Accessories

Geräte / Zubehör

15

Choledochoscopy

Choledochoskopie

16

Training models

Trainingsmodelle

Basic Set

for all laparoscopic Operations

Basis-Set

für alle laparoskopischen Eingriffe

Artikel	Article	Typen / Types	Seite / Page	Pcs
INSUFFLATOR Highflow 45 EVAC + HEAT	<i>INSUFFLATOR Highflow 45 EVAC + HEAT</i>	22350311	BDE 152	1
VERES-Kanüle	<i>VERES cannula</i>	8302.12	BDE 156	1
FLUID CONTROL LAP 2216 Set	<i>FLUID CONTROL LAP 2216 Set</i>	22160011	BDE 163	1
LED-Lichtquelle ENDOLIGHT LED 2.1 Set	<i>LED Light Source ENDOLIGHT LED 2.1 Set</i>	51630011	Imaging	1
Fiber Lichtleiter	<i>Fiber Light cable</i>		Imaging	1
ENDOCAM Logic HD	<i>ENDOCAM Logic HD</i>	5525	Imaging	1
Monitore	<i>Monitors</i>		Imaging	1
Gerätewagen	<i>Unit trolley</i>		Imaging	1

Basic Set

for laparoscopic Cholecystectomy

Basis-Set

zur laparoskopischen Cholezystektomie

Artikel	Article	Typen / Types	Seite / Page	Stk./pcs.
Optik 10 mm, 30°	Telescope 10 mm, 30°	8934.432	BDE 18	1
und/oder	and/or			
Optik 10 mm, 0°	Telescope 10 mm, 0°	8934.431	BDE 18	1
Fiber Lichtleiter	Fiber light cable	806650231	BDE 18	1
RIWO-ART-Trokarhülse 5,5 mm	RIWO-ART trocar sleeve 5.5 mm	8921.013	BDE 28	2-3
Trokar, kegelig-spitz	Trocar, conical tip	8921.113	BDE 28	2-3
und/oder	and/or			
Trokarhülse 5,5 mm, selbsthaltend	Trocar sleeve 5.5 mm, self-retaining	8919.351	BDE 32	2-3
Trokar, kegelig-spitz	Trocar, conical tip	8919.3512	BDE 32	2-3
Trokarhülse 10 mm	Trocar sleeve 10 mm	8923.013	BDE 34	2
Trokar, kegelig-spitz	Trocar, conical tip	8923.113	BDE 34	2
Führungsstab 5 mm	Guide rod 5 mm	8923.921	BDE 39	1
Dilatations- und Führungshülse 5-10 mm	Dilatation and guide sleeve 5-10 mm	8923.931	BDE 39	1
Instrumentierhülse und Extraktor 5-10 mm	Instrument sleeve and extractor 5-10 mm	8385.50	BDE 39	1
Veres-Kanüle	VERES cannula	8302.12	BDE 1156	1
Multifunktionelles Saug-Spül-System <i>Multifunction Suction-Irrigation System</i>				
Saug-Spül-Rohr 5 mm	Suction-Irrigation tube 5 mm	8383.911	BDE 90	1
Saug-Spül-Handgriff	Suction-Irrigation handle	8385.901	BDE 90	1
Verschlusskappe	Sealing cap	8385.902	BDE 90	1
ERAGONmodular <i>ERAGONmodular</i>				
Greifzange mit Zahnreihe 5 mm	Grasping forceps with teeth 5 mm	83932925	BDE 60	1
Atraumatische Greifzange 5 mm	Atraumatic grasping forceps 5 mm	83931817	BDE 65	2
Maryland Dissektor 5 mm	Maryland dissector 5 mm	83932817	BDE 53	1
Schere "Metzenbaum" 5 mm	Scissors "Metzenbaum" 5 mm	83930417	BDE 74	1
Greifzange, 2/3 krallig, 10 mm	Grasping forceps, 2/3 claws, 10 mm	83952048	BDE 70	1
Atraumatische Tellerfasszange 10 mm	Atraumatic plate-shaped grasping forceps 10 mm	83952347	BDE 70	1
Haken-Elektrode 5 mm <i>Hook electrode 5 mm</i>				
Clip-Applikator 10 mm	Clip applicator 10 mm	8389.911	BDE 105	1
Ligaclips, VE=108 Stück	Ligaclips, PACK=108 PCS	8389.915	BDE 105	1
Nadelzange	Needle-tipped grasper	8756.201	BDE 114	1
Dichtkonus, 12-15 mm	Closure cone, 12-15 mm	8943.915	BDE 114	1
HF-Anschlusskabel	HF connecting cable	8106	BDE 163	2

Basic Set

for laparoscopic Cholecystectomy

Basis-Set

zur laparoskopischen Cholezystektomie

Artikel	Article	Typen / Types	Seite / Page	Stk./pcs.
Zusätzlich auf Wunsch:	Options:			
Optik 5,3 mm, 30°	Telescope 5.3 mm, 30°	8935.442	BDE 18	1
Trokar mit Schutzhülse	Trocar with protective sleeve	8923.133	BDE 34	1
RIWO-ART Trokarhülse 5,5 mm	RIWO-ART trocar sleeve 5.5 mm	8921.013	BDE 39	1
Trokar, kegelig-spitz	Trocar, conical tip	8921.113	BDE 39	1
ERAGONmodular	ERAGONmodular			
Greifzange, stumpf, 5 mm	Grasping forceps, blunt, 5 mm	83931957	BDE 62	1
Probe-Exzisionszange 5 mm	Biopsy forceps 5 mm	83930937	BDE 66	1
Dissektionszange 10 mm	Dissection forceps 10 mm	83952268	BDE 69	1
ERAGONbipolar	ERAGONbipolar			
Greif- und Präparierzange, bipolar, 5 mm	Grasping and preparation forceps, 5 mm	839300312	BDE 83	1
Bipolar-Kabel	Bipolar cable	8108	BDE 164	1

1

Basic Set

for laparoscopic Cholecystectomy

Basis-Set

zur laparoskopischen Cholezystektomie

Artikel	Article	Typen / Types	Seite / Page	Stk. / pcs.
Zusätzlich zur laparoskopischen Choledochusrevision:		<i>Options for laparoscopic inspection of the common bile duct:</i>		
Cholangiografie-Zange	<i>Cholangiography forceps</i>	8383.311	BDE 81	1

1

Basic Set

for laparoscopic Appendectomy

Basis-Set

zur laparoskopischen Appendektomie

Artikel	Article	Typen / Types	Seite / Page	Stk. / pcs.
Optik 10 mm, 30°	Telescope 10 mm, 30°	8934.432	BDE 18	1
und/oder	and/or			
Optik 10 mm, 0°	Telescope 10 mm, 0°	8934.431	BDE 18	1
Fiber Lichtleiter	Fiber light cable	806650231	BDE 18	1
RIWO-ART-Trokarhülse 10 mm	RIWO-ART-trocar sleeve 10 mm	8923.013	BDE 28	2
Trokar, kegelig-spitz	Trocar, conical tip	8923.113	BDE 28	2
und/oder	and/or			
Trokarhülse 5,5 mm, selbsthaltend	Trocar sleeve 5.5 mm, self-retaining	8919.351	BDE 32	2-3
Trokar, kegelig-spitz	Trocar, conical tip	8919.3512	BDE 32	2-3
RIWO-ART-Trokarhülse 5,5 mm	RIWO-ART-trocar sleeve 5.5 mm	8921.013	BDE 34	2-3
Trokar, kegelig-spitz	Trocar, conical tip	8921.113	BDE 34	2-3
Führungsstab 5 mm	Guide rod 5 mm	8923.921	BDE 39	1
Instrumentierhülse und Extraktor 5-10 mm	Instrument sleeve and extractor 5-10 mm	8385.50	BDE 39	1
ERAGONmodular	ERAGONmodular			
Greif- und Koagulationszange 5 mm	Grasping and coagulation forceps 5 mm	83932877	BDE 65	1
Atraumatische Greifzange 5 mm	Atraumatic grasping forceps 5 mm	83931817	BDE 53	1
Maryland Dissektor 5 mm	Maryland dissector 5 mm	83932817	BDE 49	1
Greif- und Dissektionszange 5 mm	Grasping and dissection forceps 5 mm	83932827	BDE 52	1
Schere "Metzenbaum" 5 mm	Scissors "Metzenbaum" 5 mm	83930417	BDE 74	1
ERAGONbipolar	ERAGONbipolar			
Greif- und Präparierzange, bipolar, 5 mm	Grasping and preparation forceps, bipolar, 5 mm	839300312	BDE 83	1
Multifunktionelles Saug-Spül-System	Multifunction Suction-Irrigation System			
Saug-Spül-Rohr 5 mm	Suction-Irrigation tube 5 mm	8383.911	BDE 90	1
Saug-Spül-Handgriff	Suction-Irrigation Handle	8385.901	BDE 90	1
Verschlusskappe	Sealing cap	8385.902	BDE 90	1
Taststab 5 mm	Probe 5 mm	8383.66	BDE 119	1
VERES-Kanüle	VERES cannula	8302.12	BDE 156	1
HF-Kabel Bipolar	HF-connecting cable bipolar	8108	BDE 164	1
HF-Kabel Monopolar	HF-connecting cable monopolar	8106	BDE 163	1

Basic Set

for laparoscopic Appendectomy

Basis-Set

zur laparoskopischen Appendektomie

Artikel	Article	Typen / Types	Seite / Page	Stk./ pcs.
Zusätzlich auf Wunsch:	<i>Options:</i>			
ERAGONmodular	ERAGONmodular			
Greifzange, schlank 5 mm	Grasping forceps, tapered 5 mm	83932897	BDE 52	1
Greif- und Präparierzange 5 mm	Grasping and dissecting forceps 5 mm	83931837	BDE 54	1
Probe-Exzisionszange 5 mm	Biopsy forceps 5 mm	83930917	BDE 65	1
Greif-Dissektionszange "Maryland" 10 mm	Grasping forceps "Maryland" 10 mm	83952257	BDE 129	1
Clip-Applikator 10 mm	Clip-applicator 10 mm	8389.911	BDE 105	1
Ligaclips, VE=108 Stück	Ligaclips, PACK=108 PCS	8389.915	BDE 105	1
Einführungshülse	Insertion sleeve	8389.991	BDE 105	1
Nadelhalter 5 mm	Needle holder 5 mm	8393.502	BDE 110	1

Basic Set LEVD

Laparo-Endoscopic Varicocele Dissection in Single-Port Technique

Basis-Set LEVD

Laparoskopische Einkanal Varikozelen-Dissektion

Artikel	Article	Typen / Types	Seite / Page	Stk. / pcs.
Operations-Laparoskop 5,5 mm , 0°	<i>Operating laparoscope 5.5 mm, 0°</i>	8920.4011	BDE 14	1
Siebkorb für Optik	<i>Perforated basket for telescope</i>	38008	BDE 14	1
Fiber Lichtleiter	<i>Fiber light cable</i>	806625231	BDE 14	1
Selbsthaltende Kunststofftrokarhülse 5,5 mm	<i>Self-retaining plastic trocar sleeve 5.5 mm</i>	8919.353	BDE 32	1
hierzu:	<i>also:</i>			
Trokar, kegelig stumpf	<i>Trocar, conical with blunt tip</i>	8919.3511	BDE 32	1
Trokar, kegelig spitz	<i>Trocar, with sharp tip</i>	8919.3512	BDE 32	1
Trokar, Spitze dreikantig	<i>Trocar, with pyramid-shaped tip</i>	8919.3513	BDE 32	1
ERAGONmodular mini	<i>ERAGONmodular mini</i>			
Universal-Greifzange 3,5 mm	<i>Universal grasping forceps 3.5 mm</i>	83912097	BDE 59	1
Atraumatische Greifzange 3,5 mm	<i>Atraumatic grasping forceps 3.5 mm</i>	83912087	BDE 57	1
Greifzange "Babcock" 3,5 mm	<i>Grasping forceps "Babcock", 3.5 mm</i>	83912107	BDE 59	1
Greif- und Dissektionszange 3,5 mm	<i>Grasping and dissecting forceps 3.5 mm</i>	83912077	BDE 56	1
Hakenschere	<i>Hook scissors</i>	83912277	BDE 91	1
Schere "Metzenbaum"	<i>Scissors "Metzenbaum"</i>	83912247	BDE 91	1
HF-Kabel Bipolar	<i>HF-connecting cable bipolar</i>	8108	BDE 164	1
HF-Kabel Monopolar	<i>HF-connecting cable monopolar</i>	8106	BDE 163	1

1

Mini Fibre Telescopes 2 mm

Mini-Fiber-Optiken 2 mm

2

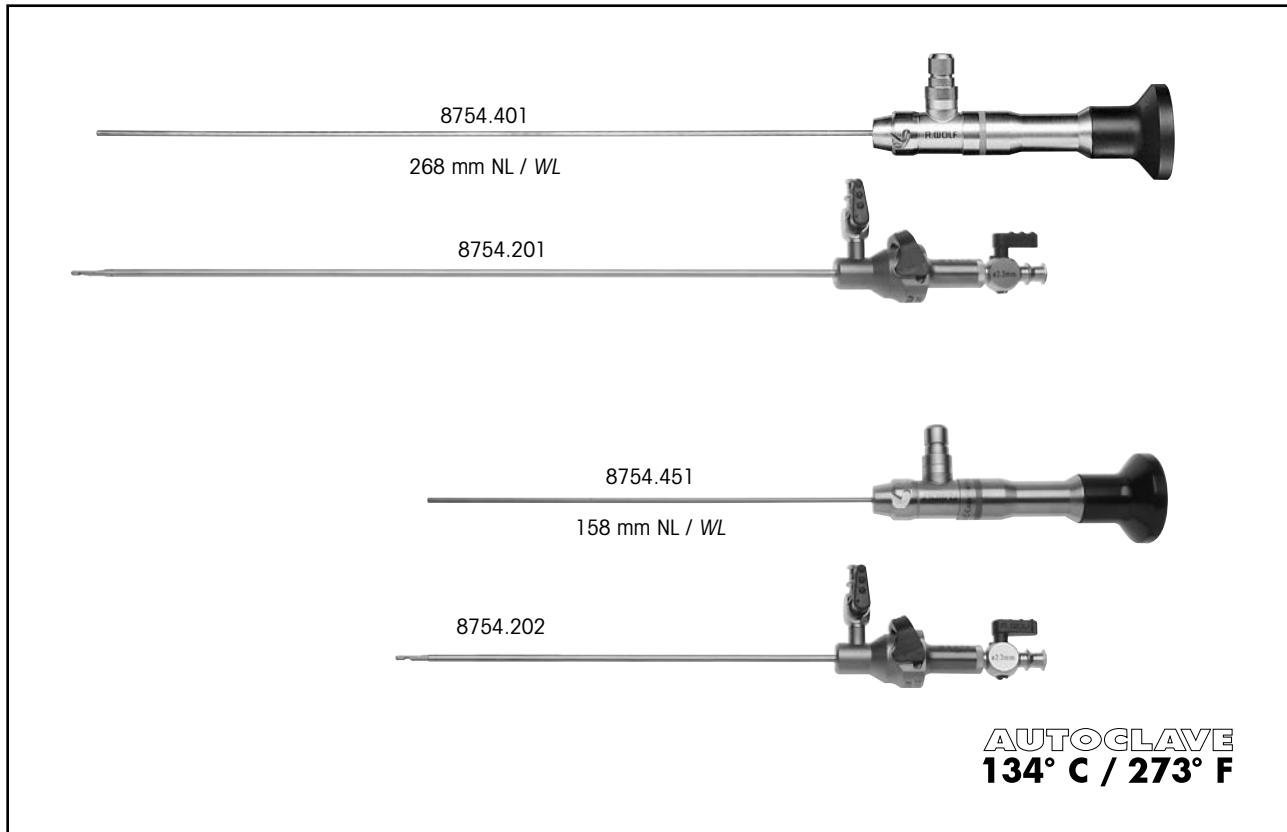

WL 268 mm standard version

- Telescope, Ø 2 mm, 0° 8754.401
- VERES needle (8754.211), Ø 2.3 mm with outer sheath (8754.221) 8754.201

WL 158 mm short version

- Telescope, Ø 2 mm, 0° 8754.451
- VERES needle (8754.212), Ø 2.3 mm with outer sheath (8754.222) 8754.202

NL 268 mm Standard-Ausführung

- Optik, Ø 2 mm, 0° 8754.401
- VERES-Kanüle (8754.211), Ø 2,3 mm mit Außenschaff (8754.221) 8754.201

NL 158 mm Kurze Ausführung

- Optik, Ø 2 mm, 0° 8754.451
- VERES-Kanüle (8754.212), Ø 2,3 mm mit Außenschaff (8754.222) 8754.202

Recommended light cable:

Fiber light cable set Ø 2.5 mm, 2.3 m long consisting of:
 Fiber light cable (80662523), adapter projector side (8095.07) and adapter endoscope side (809509) 806625231
 (for maximum light transmission)

Accessories:

- Perf. basket for standard telescope 1** (for telescope 8754.451)
 (L x W x H) 297 x 59 x 54 mm 38015
- Perf. basket for standard telescope 2** (for telescope 8754.401)
 (L x W x H) 481 x 59 x 54 mm 38016

Empfohlene Lichtleiter:

Fiber Lichtleiter Set, Ø 2,5 mm, 2,3 m lang bestehend aus:
 Fiber Lichtleiter (80662523), Adapter projektorseitig (8095.07) und Adapter endoskopseitig (809509) 806625231
 (für maximale Lichttransmission)

Zubehör:

- Siebkorb für Standardoptik 1** (für Optik 8754.451)
 (L x B x H) 297 x 59 x 54 mm 38015
- Siebkorb für Standardoptik 2** (für Optik 8754.401)
 (L x B x H) 481 x 59 x 54 mm 38016

Laparoscopes 3.5 mm

Laparoskope 3,5 mm

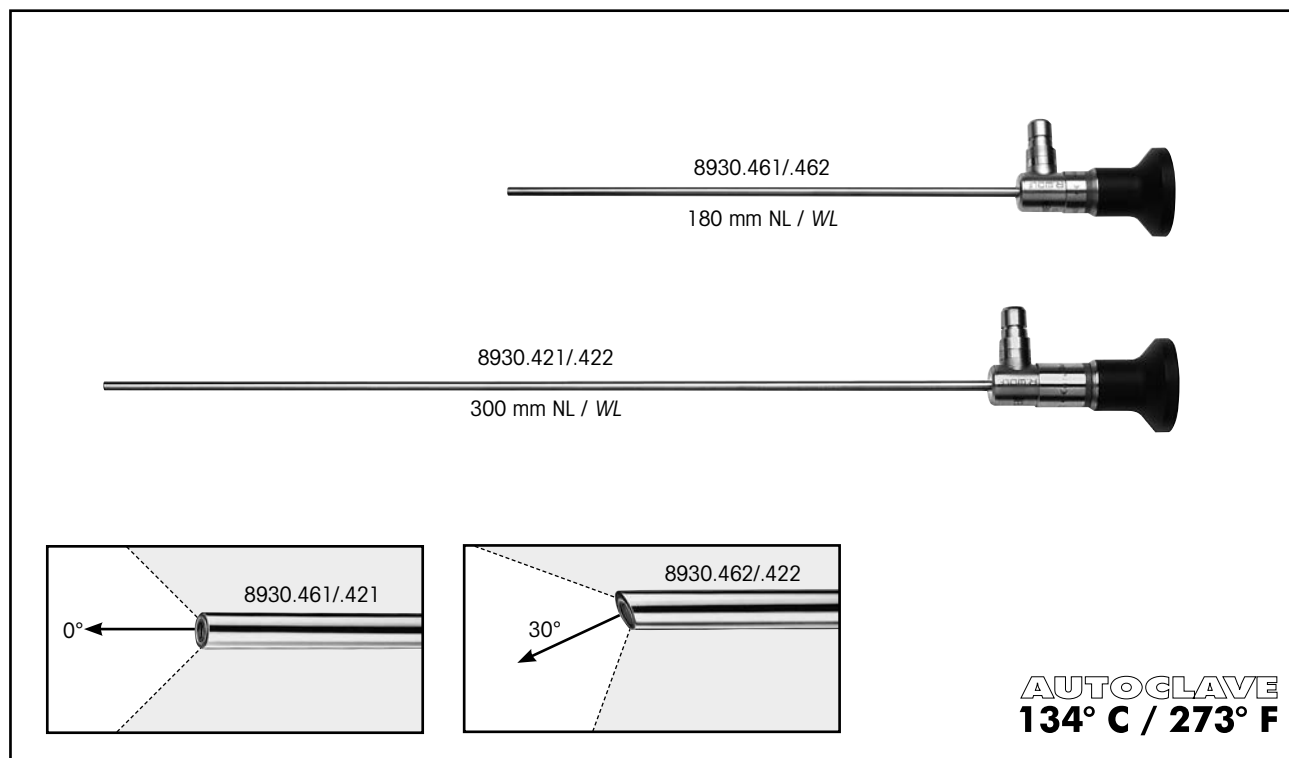

2

WL 180 mm

PANOVIEW PLUS telescope, Ø 3.5 mm,

0°	8930.461
30°	8930.462

WL 300 mm

PANOVIEW PLUS telescope, Ø 3.5 mm,

0°	8930.421
30°	8930.422

NL 180 mm

PANOVIEW PLUS-Optik, Ø 3,5 mm,

0°	8930.461
30°	8930.462

NL 300 mm

PANOVIEW PLUS-Optik, Ø 3,5 mm,

0°	8930.421
30°	8930.422

Recommended light cable:

Fiber light cable set Ø 2.5 mm, 2.3 m long consisting of:

Fiber light cable (80662523), adapter projector side (8095.07) and adapter endoscope side (809509) 806625231
(for maximum light transmission)

Accessories:

Perf. basket for standard telescope 1 (for telescope 8930.461/.462)
(L x W x H) 297 x 59 x 54 mm 38015
Perf. basket for standard telescope 2 (for telescope 8930.421/.422)
(L x W x H) 481 x 59 x 54 mm 38016

Empfohlene Lichtleiter:

Fiber Lichtleiter Set, Ø 2,5 mm, 2,3 m lang bestehend aus:

Fiber Lichtleiter (80662523), Adapter projektorseitig (8095.07) und Adapter endoskopseitig (809509) 806625231
(für maximale Lichttransmission)

Zubehör:

Siebkorb für Standardoptik 1 (für Optik 8930.461 / .462)
(L x B x H) 297 x 59 x 54 mm 38015
Siebkorb für Standardoptik 2 (für Optik 8930.421 / .422)
(L x B x H) 481 x 59 x 54 mm 38016

Laparoscopes 5.3 mm

‡ distortion-free

Laparoskope 5,3 mm

‡ verzeichnungsfrei

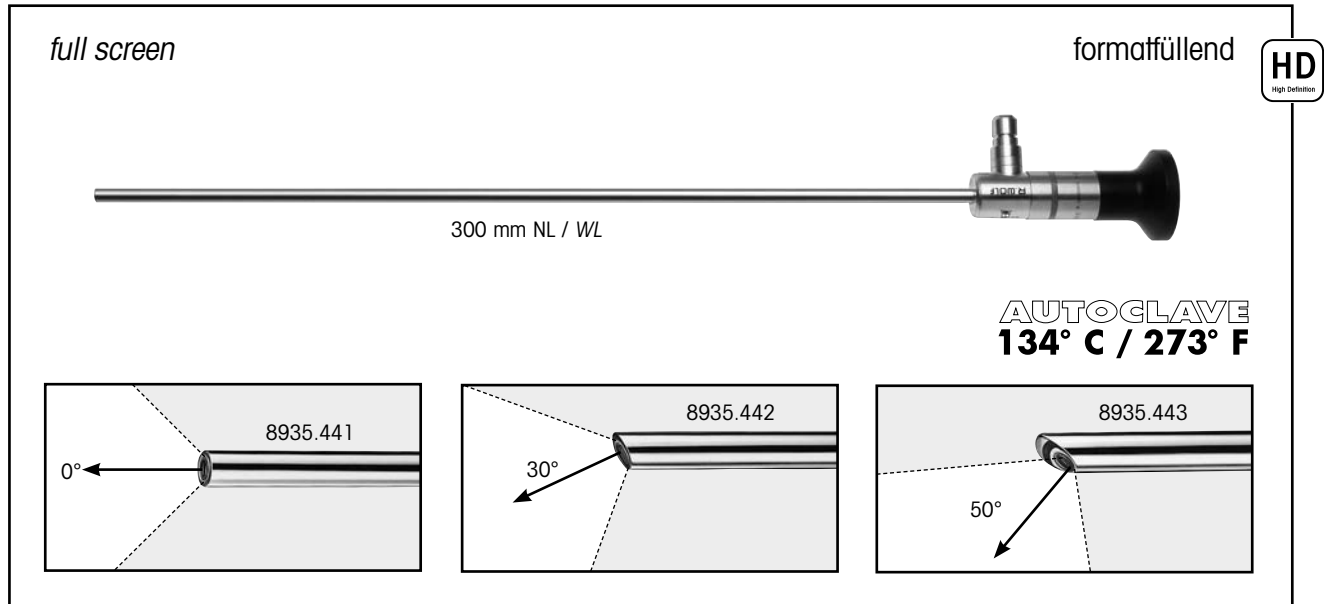

**PANOVIEW telescope, Ø 5.3 mm,
distortion-free, full screen,**

0°	8935.441
30°	8935.442
50°	8935.443

**PANOVIEW-Optik, Ø 5,3 mm,
verzeichnungsfrei, formatfüllend**

0°	8935.441
30°	8935.442
50°	8935.443

Recommended light cable:

Fiber light cable set Ø 3.5 mm, 2.3 m long consisting of:
Fiber light cable (80663523), adapter projector side (8095.07) and
adapter endoscope side (809509) 806635231
(for maximum light transmission)

Empfohlene Lichtleiter:

Fiber Lichtleiter Set, Ø 3,5 mm, 2,3 m lang bestehend aus:
Fiber Lichtleiter (80663523), Adapter projektorseitig (8095.07) und
Adapter endoskopseitig (809509) 806635231
(für maximale Lichttransmission)

Accessories:

Perf. basket for standard telescope 2
(L x W x H) 481 x 59 x 54 mm 38016

Zubehör:

Siebkorb für Standardoptik 2
(L x B x H) 481 x 59 x 54 mm 38016

Mini-Operating-Laparoscope
5.5 mm with 3.5 mm Working Channel

Mini-OP-Laparoskop
5,5 mm mit 3,5 mm Arbeitskanal

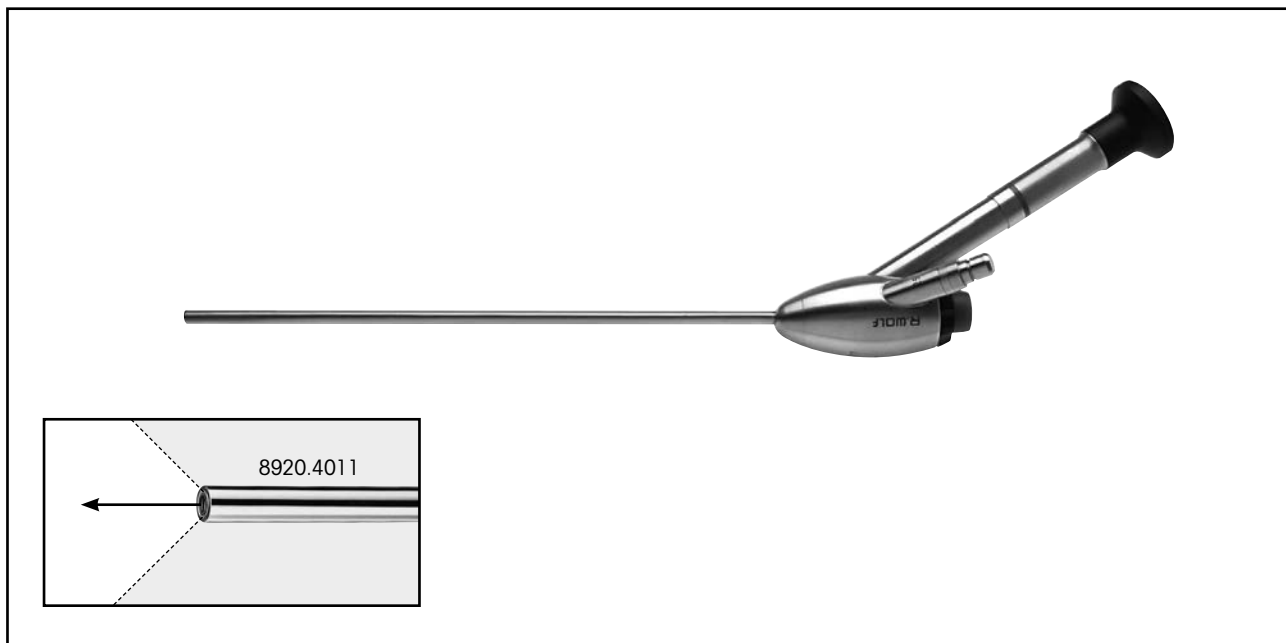

2

OP Endoscope bundle, Ø 5.3 mm, SL 215 mm
consisting of:
OP endoscope with 3.5 mm working channel, silicate image guide (8920.401), sealing element (8920.311), sealing cap (15176.020),
0° 8920.4011

Spare membrane valves, yellow, PACK=10 PCS 89.103

Recommended light cable:

Fiber light cable set Ø 2.5 mm, 2.3 m long consisting of:
Fiber light cable (80662523), adapter projector side (8095.07) and adapter endoscope side (809509) 806625231
(for maximum light transmission)

The trocar sleeves 8919.333 / .353 see page BDE 32 with optimised working length are recommended.

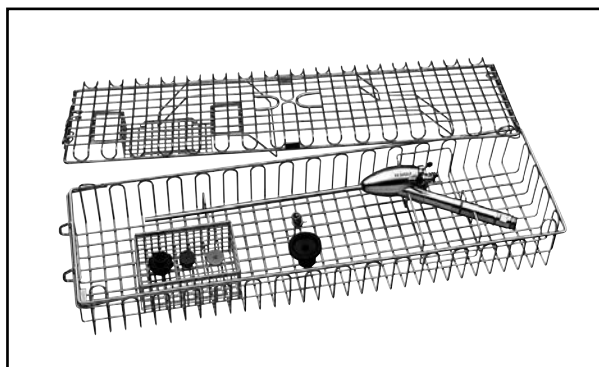

OP-Endoskop komplett, Ø 5.3 mm, SL 215 mm
bestehend aus:
OP-Endoskop mit 3,5 mm Arbeitskanal, Silikat-Bildleiter (8920.401), Dichtungsteil (8920.311), Dichtungskappe (15176.020),
0° 8920.4011

Ersatz-Membran-Ventil, gelb, VE=10 ST 89.103

Empfohlene Lichtleiter:

Fiber Lichtleiter Set, Ø 2,5 mm, 2,3 m lang bestehend aus:
Fiber Lichtleiter (80662523), Adapter projektorseitig (8095.07) und Adapter endoskopseitig (809509) 806625231
(für maximale Lichttransmission)

Empfohlen werden die in der Nutzlänge optimierten Trokarhülsen 8919.333 / .353 siehe Seite BDE 32.

Siebkorb für Optik

Abmessungen (B x L x H): 132 x 467 x 75 mm 38008

For machine reprocessing and sterilization:

Perforated basket for telescope
Dimensions (l x w x h): 132 x 467 x 75 mm 38008

Telescopes 5.5 mm
optimized for 4K UHD

Optiken 5,5 mm
optimiert für 4K UHD

2

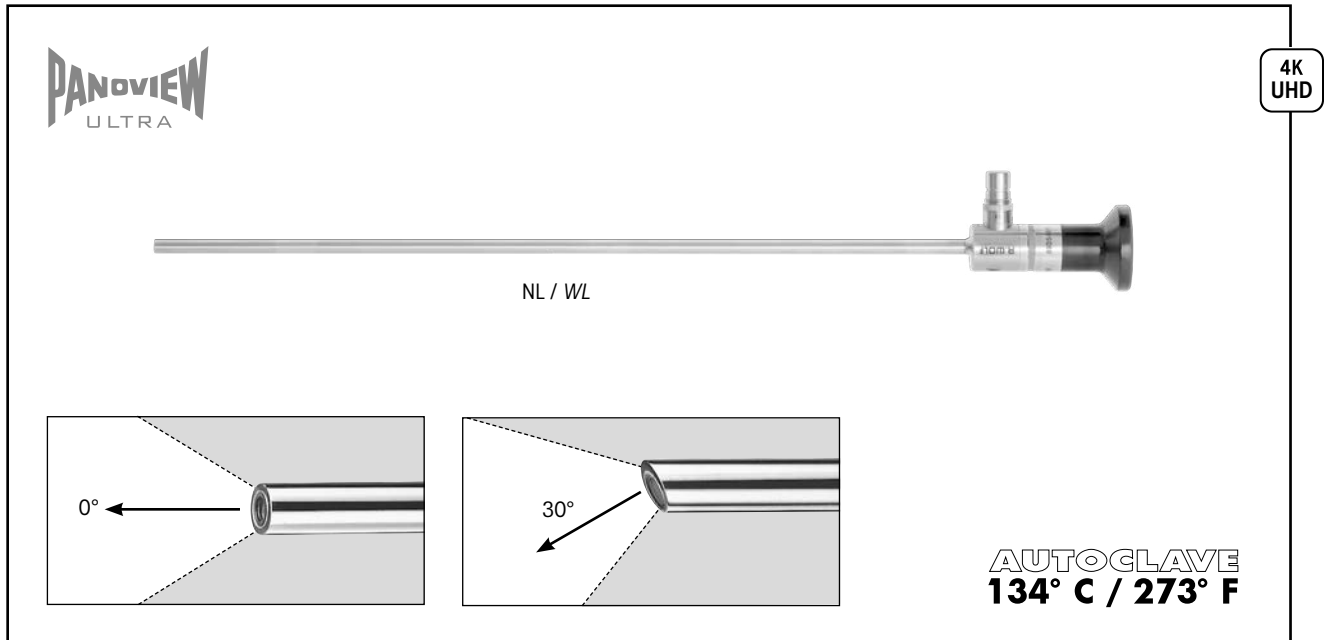

PANOVIEW ULTRA
telescope Ø 5.5mm WL 300mm

0°	8935461
30°	8935462

PANOVIEW ULTRA
Optik Ø 5,5mm NL 300mm

0°	8935461
30°	8935462

Recommended light cable:
Fiber light cable bundle,
Ø 5.0 mm, 2.3 m long consisting of:
Fiber light cable (80665023),
adapter on the projector side (8095.07) and
adapter on the endoscope side (809509) 806650231

Empfohlene Lichtleiter:
Fiber Lichtleiter komplett,
Ø 5,0 mm, 2,3 m lang bestehend aus:
Fiber Lichtleiter (80665023),
Adapter projektorseitig (8095.07) und
Adapter endoskopseitig (809509) 806650231

Fusion fiber light cable bundle,
Ø 5.0 mm, 2.3 m long consisting of:
Fusion fiber light cable (80655023),
adapter on the projector side (8095.07) and
adapter on the endoscope side (809509) 806550231

Fusion Fiber Lichtleiter komplett,
Ø 5,0 mm, 2,3 m lang bestehend aus:
Fusion Fiber Lichtleiter (80655023),
Adapter projektorseitig (8095.07) und
Adapter endoskopseitig (809509) 806550231

Accessories:
Perf. basket for standard telescope 2
(L x W x H) 481 x 59 x 54 mm 38016

Zubehör:
Siebkorb für Standardoptik 2
(L x B x H) 481 x 59 x 54 mm 38016

Telescopes 5.5 mm
optimized for 4K UHD
long version

Optiken 5,5 mm
optimiert für 4K UHD
lange Ausführung

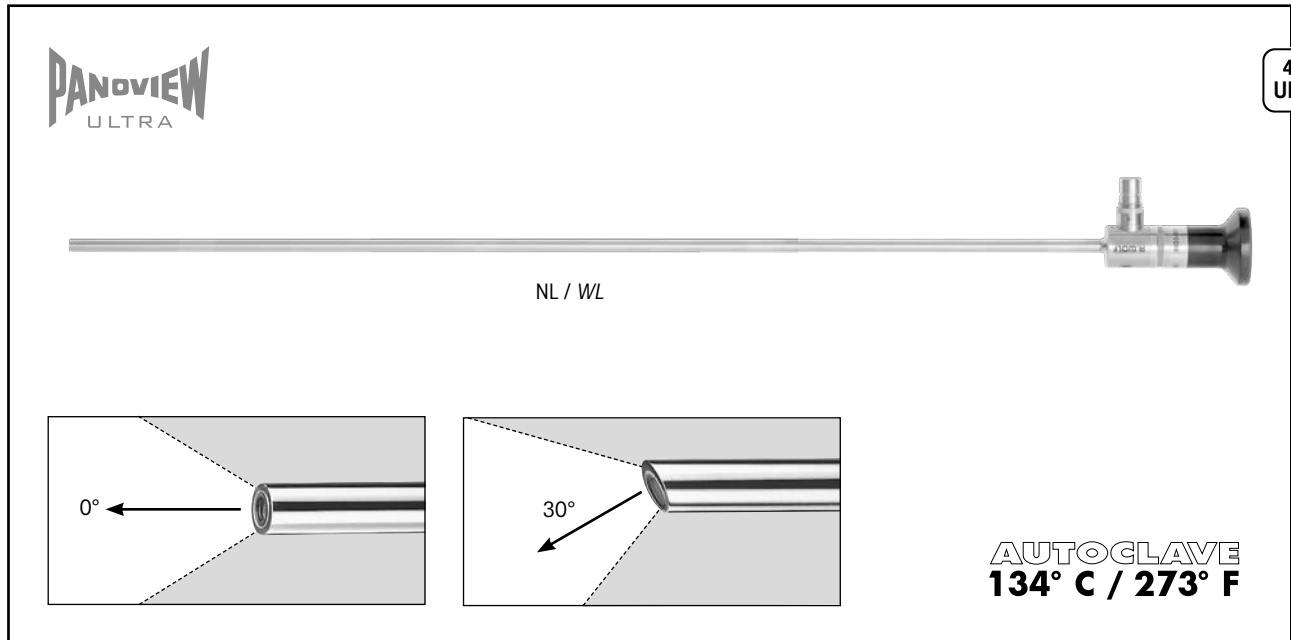

PANOVIEW ULTRA
telescope Ø 5.5mm WL 430mm

0°	89354416
30°	89354426

PANOVIEW ULTRA
Optik Ø 5,5 mm NL 430mm

0°	89354416
30°	89354426

Recommended light cable:

Fiber light cable bundle,

Ø 5.0 mm, 2.3 m long consisting of:

Fiber light cable (80665023),

adapter on the projector side (8095.07) and

adapter on the endoscope side (809509) 806650231

Fusion fiber light cable bundle, Ø 5.0 mm, 2.3 m long

consisting of:

Fusion fiber light cable (80655023),

adapter on the projector side (8095.07) and

adapter on the endoscope side (809509) 806550231

Accessories:

Perf. basket for standard telescope 3

(L x W x H) 619 x 59 x 54 mm 38017

Empfohlene Lichtleiter:

Fiber Lichtleiter komplett,

Ø 5,0 mm, 2,3 m lang bestehend aus:

Fiber Lichtleiter (80665023),

Adapter projektorseitig (8095.07) und

Adapter endoskopseitig (809509) 806650231

Fusion Fiber Lichtleiter komplett, Ø 5,0 mm, 2,3 m lang

bestehend aus:

Fusion Fiber Lichtleiter (80655023),

Adapter projektorseitig (8095.07) und

Adapter endoskopseitig (809509) 806550231

Zubehör:

Siebkorb für Standardoptik 3

(L x B x H) 619 x 59 x 54 mm 38017

Laparoscopes 10 mm

distortion-free

Laparoskope 10 mm

verzeichnungsfrei

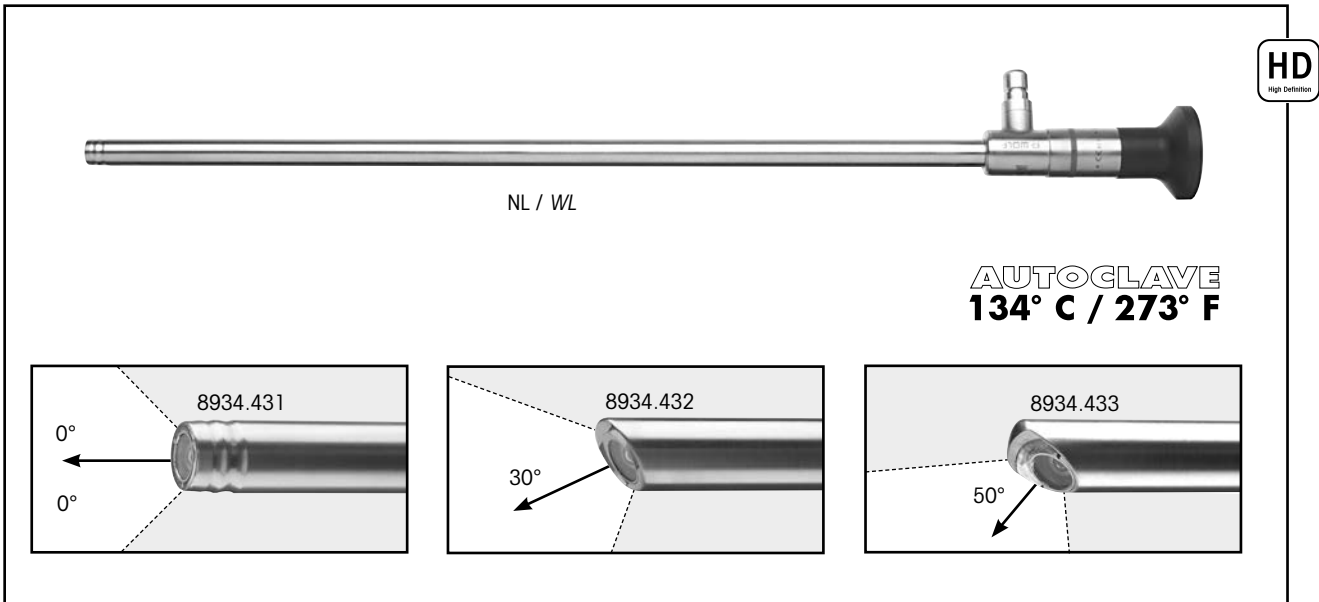

PANOVIEW

telescope 0° Ø 10mm WL 307mm	8934.431
telescope 30° Ø 10mm WL 307mm	8934.432
telescope 50° Ø 10mm WL 310mm	8934.433

PANOVIEW

Optik 0° Ø 10mm NL 307mm	8934.431
Optik 30° Ø 10mm NL 307mm	8934.432
Optik 50° Ø 10mm NL 310mm	8934.433

Recommended light cable:

Fiber light cable set Ø 5.0 mm, 2.3 m long consisting of:
Fiber light cable (80665023), adapter projector side (8095.07) and
adapter endoscope side (809509) 806650231
(for maximum light transmission)

Fiber light cable set , high-temperature resistant,
Ø 5.0 mm, 2.3 m long consisting of:
Fiber light cable (80655023), adapter projector side (8095.07) and
adapter endoscope side (809509) 806550231
(for maximum light transmission)

Accessories:

Perf. basket for standard telescope 2
Dimensions (l x w x h): 481 x 59 x 54 mm 38016

Empfohlene Lichtleiter:

Fiber Lichtleiter Set, Ø 5,0 mm, 2,3 m lang bestehend aus:
Fiber Lichtleiter (80665023), Adapter projektorseitig (8095.07) und
Adapter endoskopseitig (809509) 806650231
(für maximale Lichttransmission)

Fiber Lichtleiter Set , hochtemperaturbeständig,
Ø 5,0 mm, 2,3 m lang bestehend aus:
Fiber Lichtleiter (80655023), Adapter projektorseitig (8095.07) und
Adapter endoskopseitig (809509) 806550231
(für maximale Lichttransmission)

Zubehör:

Siebkorb für Standardoptik 2
Abmessungen (L x B x H) 481 x 59 x 54 mm 38016

Laparoscopes 10 mm
long version

Laparoskope 10 mm
Lange Ausführung

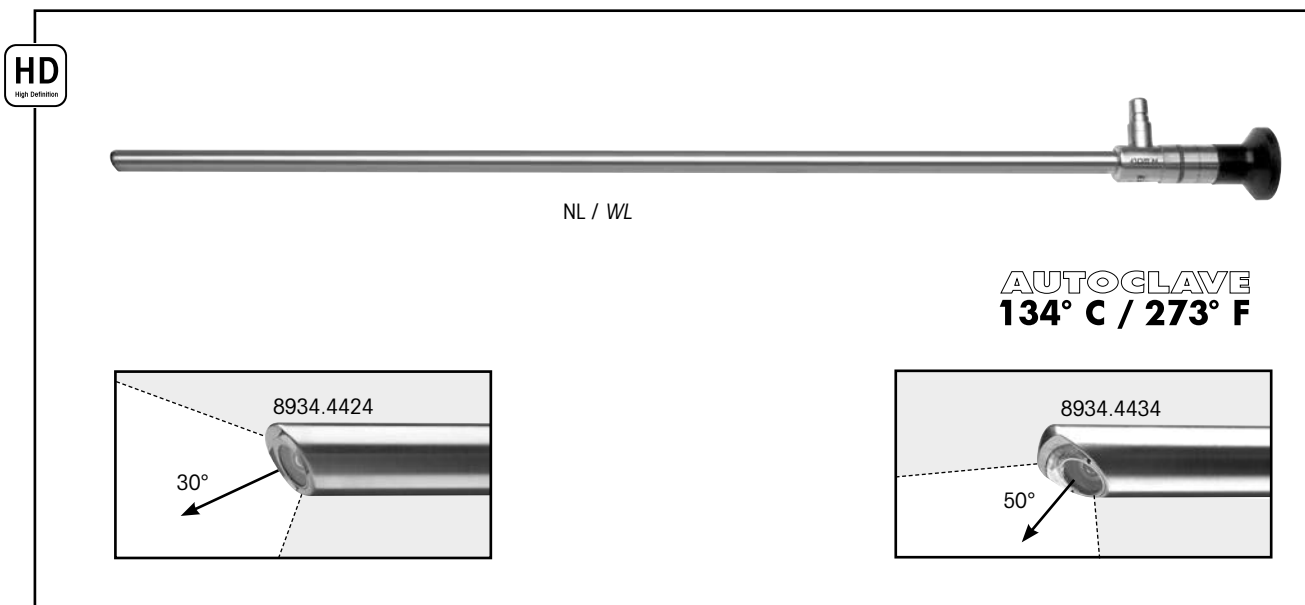

2

PANOVIEW PLUS

telescope 25° Ø 10 mm WL 438mm	8934.4424
telescope 50° Ø 10 mm WL 447mm	8934.4434

PANOVIEW PLUS

Optik 25° Ø 10mm NL 438mm	8934.4424
Optik 50° Ø 10mm NL 447mm	8934.4434

Recommended light cable:

Fiber light cable set Ø 5.0 mm, 2.3 m long consisting of:
Fiber light cable (80665023), adapter projector side (8095.07) and
adapter endoscope side (809509) 806650231
(for maximum light transmission)

Fiber light cable set *Fusion*, high-temperature resistant,
Ø 5.0 mm, 2.3 m long consisting of:
Fiber light cable (80655023), adapter projector side (8095.07) and
adapter endoscope side (809509) 806550231
(for maximum light transmission)

Accessories:

Perf. basket for standard telescope 3
(L x W x H) 619 x 59 x 54 mm 38017

Empfohlene Lichtleitkabel:

Fiber Lichtleiter Set, Ø 5,0 mm, 2,3 m lang bestehend aus:
Fiber Lichtleiter (80665023), Adapter projektorseitig (8095.07) und
Adapter endoskopseitig (809509) 806650231
(für maximale Lichttransmission)

Fiber Lichtleiter Set *Fusion*, hochtemperaturbeständig,
Ø 5,0 mm, 2,3 m lang bestehend aus:
Fiber Lichtleiter (80655023), Adapter projektorseitig (8095.07) und
Adapter endoskopseitig (809509) 806550231
(für maximale Lichttransmission)

Zubehör:

Siebkorb für Standardoptik 3
(L x B x H) 619 x 59 x 54 mm 38017

3D Endoscopes 10 mm

distortion-free

3D Endoskop 10 mm

verzeichnungsfrei

2

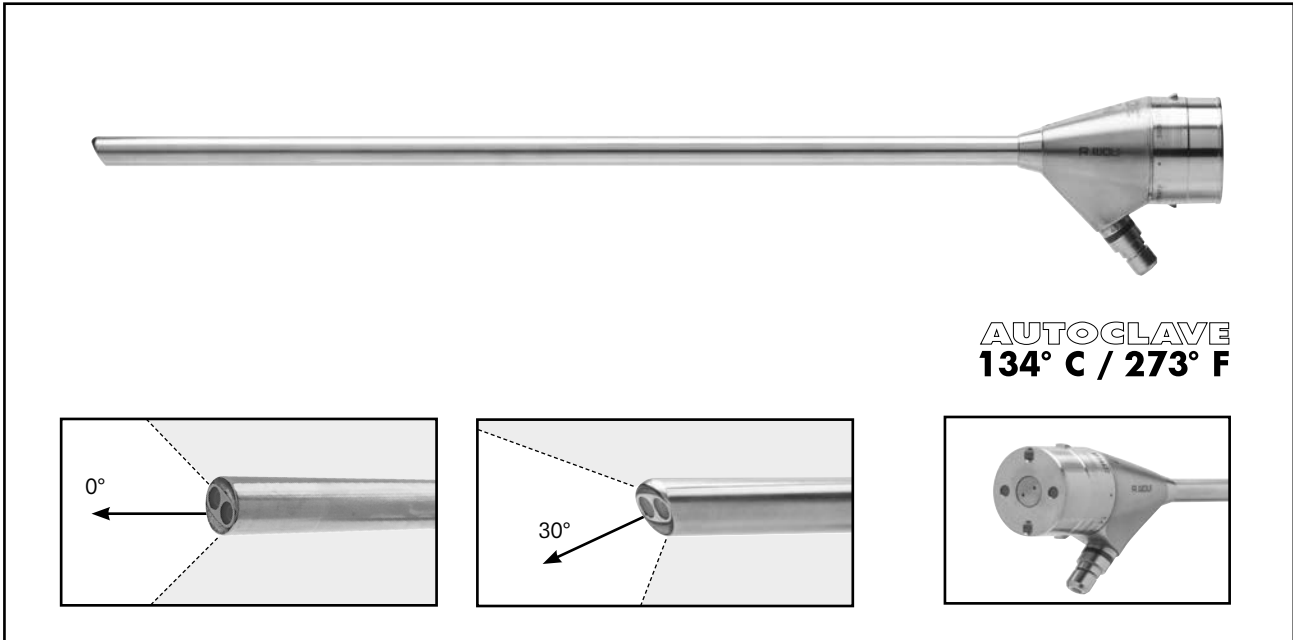

3D endoscope bundle, Ø 10 mm, 0° Set, distortion-free,
 consisting of:
 3DHD telescope (8934631), 300 mm WL
 and perforated basket (38014) 89346311
 3DHD telescope (89344631), 430 mm WL
 and perforated basket (38014) 893446311

3D endoscope bundle, Ø 10 mm, 30° Set, distortion-free,
 consisting of:
 3DHD endoscope (8934632), 300 mm WL
 and perforated basket (38014) 89346321
 3DHD telescope (89344632), 430 mm WL
 and perforated basket (38014) 893446321

Recommended light cable:
Fiber light cable set *Fusion*, high-temperature resistant,
 Ø 5.0 mm, 2.3 m long consisting of:
 Fiber light cable (80655023), adapter projector side (8095.07) and
 adapter endoscope side (809509) 806550231
 (for maximum light transmission)

3D Endoskop komplett, Ø 10 mm, 0° Set, verzeichnungsfrei,
 bestehend aus:
 3DHD Optik (8934631), 300 mm NL
 und Siebkorb (38014) 89346311
 3DHD Opik (89344631), 430 mm NL
 und Siebkorb (38014) 893446311

3D Endoskop komplett, Ø 10 mm, 30° Set, verzeichnungsfrei,
 bestehend aus:
 3D Endoskop (8934632), 300 mm NL
 und Siebkorb (38014) 89346321
 3DHD Endoskop (89344632), 430 mm NL
 und Siebkorb (38014) 893446321

Empfohlene Lichtleiter:
Fiber Lichtleiter Set *Fusion*, hochtemperaturbeständig,
 Ø 5,0 mm, 2,3 m lang bestehend aus:
 Fiber Lichtleiter (80655023), Adapter projektorseitig (8095.07) und
 Adapter endoskopseitig (809509) 806550231
 (für maximale Lichttransmission)

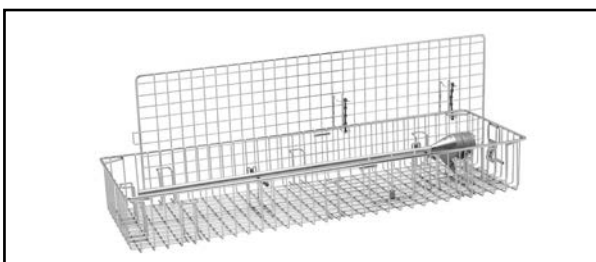

Siebkorb für 3D-Optik
 (L x B x H): 583 x 200 x 80 mm 38014

Perforated basket for 3D telescope
 (L x W x H): 583 x 200 x 80 mm 38014

*Operating
Laparoscope 10 mm*

distortion-free, with 5 mm working channel
for one hole appendectomy

Operations-
Laparoskop 10 mm

verzeichnungsfrei, mit 5 mm Arbeitskanal
für die One Hole Appendectomie

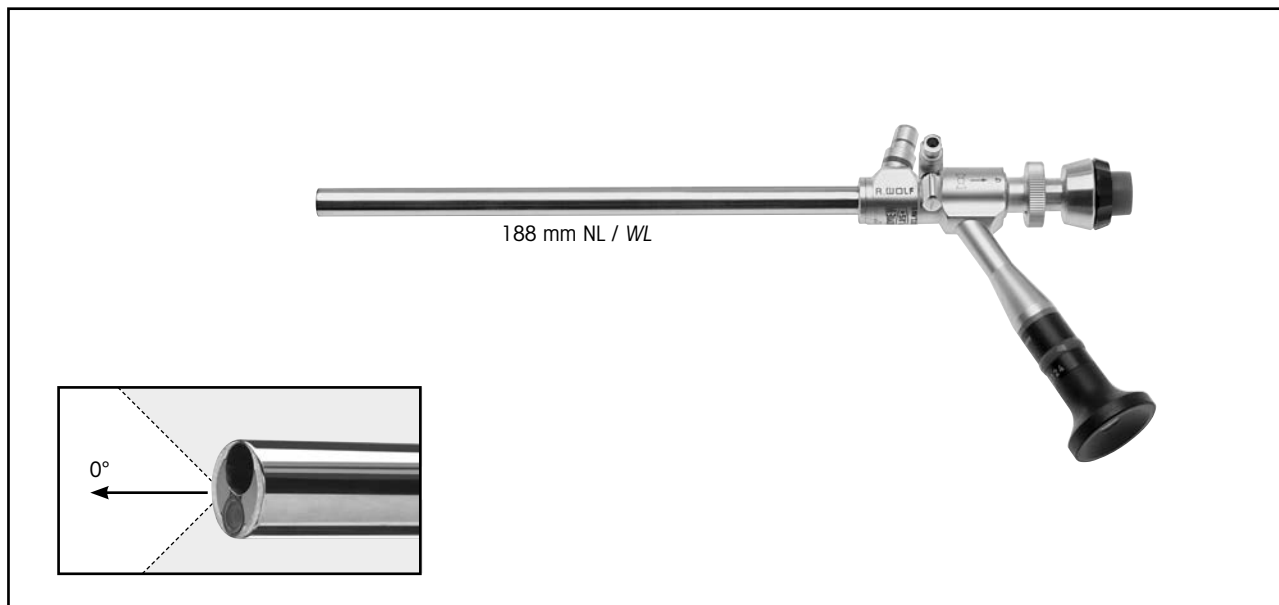

2

PANOVUE PLUS OP endoscope, Ø 10 mm,
with oblique eyepiece, working channel 5.1 mm,
0° 8915.501

PANOVUE PLUS-OP-Endoskop, Ø 10 mm,
mit schrägem Okulareinblick, Arbeitskanal 5,1 mm,
0° 8915.501

Recommended light cable:

Fiber light cable set Ø 5.0 mm, 2.3 m long consisting of:
Fiber light cable (80665023), adapter projector side (8095.07) and
adapter endoscope side (809509)..... 806650231
(for maximum light transmission)

Empfohlene Lichtleiter:

Fiber Lichtleiter Set, Ø 5,0 mm, 2,3 m lang bestehend aus:
Fiber Lichtleiter (80665023), Adapter projektorseitig (8095.07) und
Adapter endoskopseitig (809509) 806650231
(für maximale Lichttransmission)

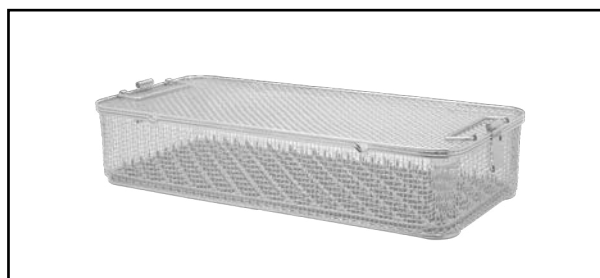

Universalsiebkorb 4
(B x H x T): 538 x 117 x 250 mm 33004
hierzu:
Instrumentenmatte für Siebkorb 33301

Universal perforated basket 4
(w x h x d): 530 x 108 x 250 mm 33004
also:
Instrument mat for perforated basket 33301

Telescopes 10 mm
optimized for 4K UHD
and NIR/ICG application

Optiken 10 mm
optimiert für 4K UHD
und NIR/ICG Anwendung

2

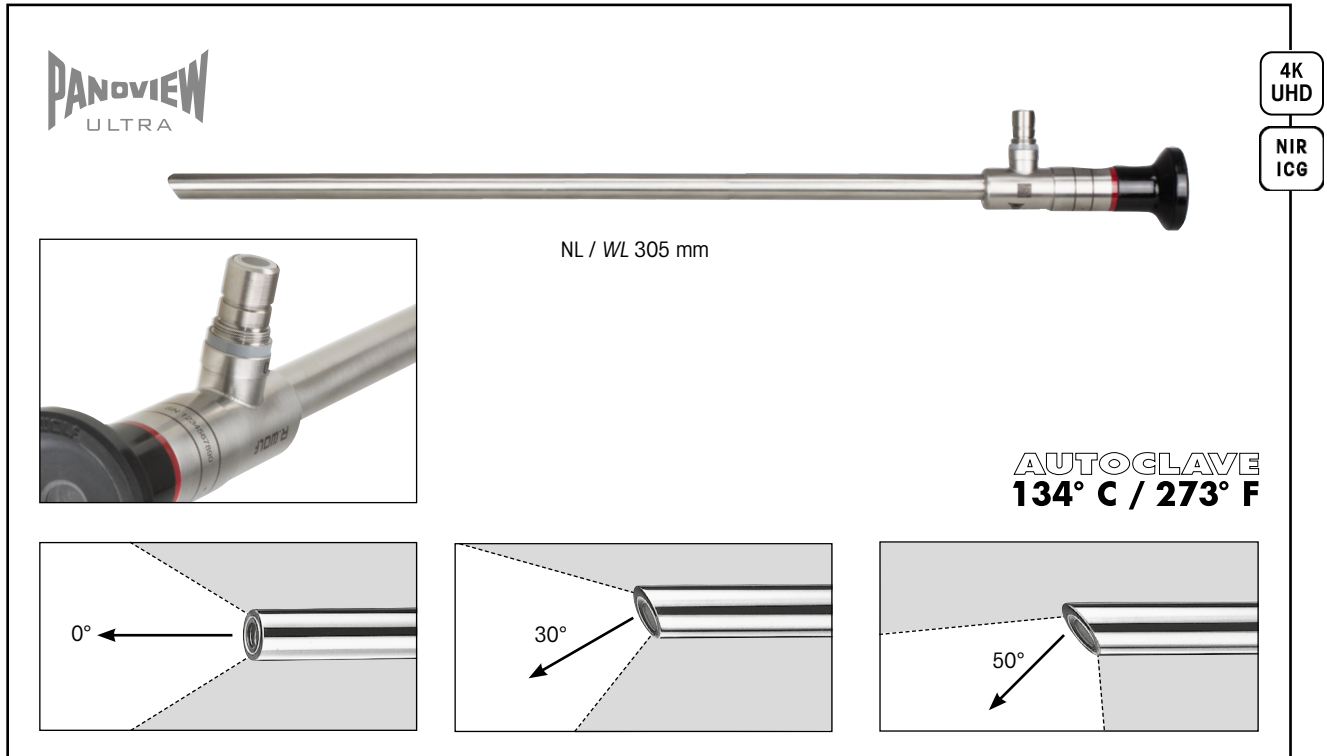

PANOVIEW ULTRA

Telescope Ø 10 mm WL 305 mm

0°	8934461
30°	8934462
50°	8934463

Recommended light cable:

Fusion fiber light cable bndl,

Ø 5.0 mm, 2.3 m long consisting of:
Fusion Fiber light cable (80655023),
adapter projector side (8095.07) and
adapter endoscope side (809509) 806550231

Fiber light cable bndl,

Ø 5.0 mm, 2.3 m long consisting of:
Fiber light cable (80665023),
adapter projector side (8095.07) and
adapter endoscope side (809509) 806650231

Accessories:

Reprocess basket

(L x W x H) 471 x 59 x 54 mm 38021.111

Note: Compatible with System green (NIR/ICG capable) and the recommended fusion fiber light cable.

PANOVIEW ULTRA

Optik Ø 10 mm NL 305 mm

0°	8934461
30°	8934462
50°	8934463

Empfohlene Lichtleiter:

Fusion Fiber Lichtleiter kpl,

Ø 5,0 mm, 2,3 m lang bestehend aus:
Fusion Fiber Lichtleiter (80655023),
Adapter projektorseitig (8095.07) und
Adapter endoskopseitig (809509) 806550231

Fiber Lichtleiter kpl,

Ø 5,0 mm, 2,3 m lang bestehend aus:
Fiber Lichtleiter (80665023),
Adapter projektorseitig (8095.07) und
Adapter endoskopseitig (809509) 806650231

Zubehör:

Aufbereitungskorb

(L x B x H) 471 x 59 x 54 mm38021.111

Hinweis: Kompatibel mit System green (NIR/ICG fähig) und dem dafür empfohlenen Fusion Fiber Lichtleiter.

*Telescopes 10 mm
optimized for 4K UHD
and NIR/ICG application*

Optiken 10 mm
optimiert für 4K UHD
und NIR/ICG Anwendung

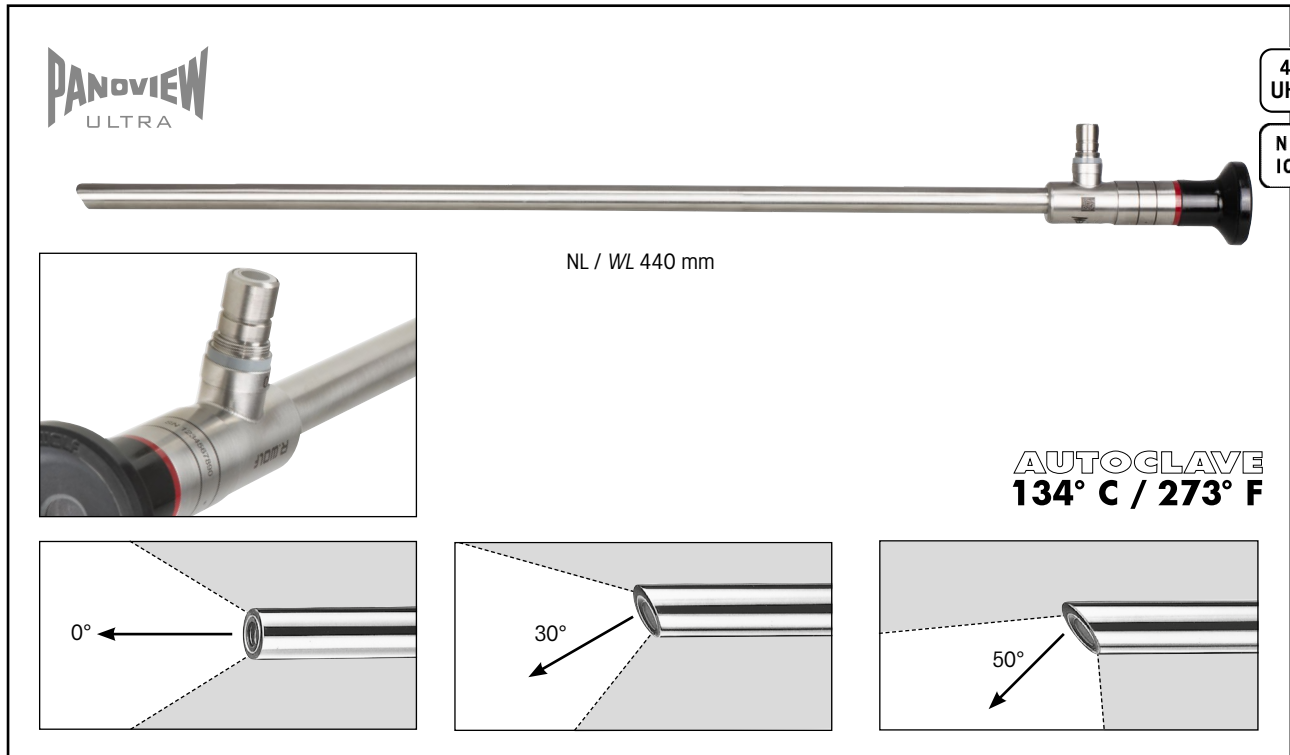

PANOVIEW ULTRA

Telescope Ø 10 mm WL 440 mm

0°	89344416
30°	89344426
50°	89344436

Recommended light cable:

Fusion fiber light cable bndl,

Ø 5.0 mm, 2.3 m long consisting of:
Fusion fiber light cable (80655023),
adapter projector side (8095.07) and
adapter endoscope side (809509) 806550231

Fiber light cable bndl,

Ø 5.0 mm, 2.3 m long consisting of:
Fiber light cable (80665023),
adapter projector side (8095.07) and
adapter endoscope side (809509) 806650231

Accessories:

Reprocessing basket

(L x W x H) 610 x 59 x 54 mm 38022.111

Note: Compatible with System green (NIR/ICG capable) and the recommended fusion fiber light cable.

PANOVIEW ULTRA

Optik Ø 10 mm NL 440 mm

0°	89344416
30°	89344426
50°	89344436

Empfohlene Lichtleiter:

Fusion Fiber Lichtleiter kpl,

Ø 5,0 mm, 2,3 m lang bestehend aus:
Fusion Fiber Lichtleiter (80655023),
Adapter projektorseitig (8095.07) und
Adapter endoskopseitig (809509) 806550231

Fiber Lichtleiter kpl,

Ø 5,0 mm, 2,3 m lang bestehend aus:
Fiber Lichtleiter (80665023),
Adapter projektorseitig (8095.07) und
Adapter endoskopseitig (809509) 806650231

Zubehör:

Aufbereitungskorb

(L x B x H) 610 x 59 x 54 mm 38022.111

Hinweis: Kompatibel mit System green (NIR/ICG fähig) und dem dafür empfohlenen Fusion Fiber Lichtleiter.

Endo TORCH

*Light Tube for the MILOS Technique
(Mini Less Open Sublay Technique)*

Endo TORCH

Lichtrohr zur MILOS-Technik
(Mini Less Open Sublay-Technik)

2



	Instrumentenkanal <i>Instrument channel</i>	Ø	GL / TL	Type / Type
 Lichtrohr zur MILOS-Technik <i>Light tube for the MILOS technique</i>	5 mm	10 mm	200 mm	893420

The **light tube** for the **MILOS technique** (Mini Less Open Sublay technique) has been developed in cooperation with Dr. Reinpold, Head of the Department of Surgery at the Wilhelmsburger Hospital Groß-Sand, Hamburg, Germany, especially for the treatment of abdominal-wall/incisional hernias (open, laparoscopic assisted operation).

The **light tube** offers a 5 mm instrument channel to allow for the introduction of a grasping instrument (e.g. a 5 mm ERAGONmodular instrument) in order to position the appropriate mesh (e.g. DynaMesh CICAT). The light tube is connected to a light source and it completely illuminates the surgical area.

Das **Lichtrohr** zur **MILOS-Technik** (Mini Less Open Sublay-Technik) wurde mit Hr. Dr. Wolfgang Reinpold, Chefarzt am Wilhelmsburger Krankenhaus Groß-Sand, Hamburg speziell für die laparoskopisch-assistierte Behandlung der Bauchwand/Narbenhernie entwickelt.

Das **Lichtrohr** besitzt einen 5 mm Instrumentenkanal in welchen ein entsprechendes Instrument (ERAGONmodular, 5 mm) eingeführt werden kann, um das Netz (z.B. DynaMesh CICAT) zu platzieren.

Das Lichtrohr wird an eine Lichtquelle angeschlossen und leuchtet dann das Operationsgebiet vollständig aus.

Fusion fiber light cable bundle,

Ø 5.0 mm, 2.3 m long, consisting of:

Fusion fiber light cable (80655023),

adapter on the projector side (8095.07) and

adapter on the endoscope side (809509) 806550231

Fiber Lichtleiter komplett,

Ø 5,0 mm, 2,3 m lang bestehend aus:

Fiber Lichtleiter (80665023),

Adapter projektorseitig (8095.07) und

Adapter endoskopseitig (809509) 806650231

Laparoscopes

Accessories



Laparoskope

Zubehör

Steriladapter,

Okulartrichter für Endoskop-Wechsel unter sterilen Bedingungen,
Spannverschluss 8580.91

Sterile adapter,

plug-eyepiece for endoscope exchange under sterile conditions,
lock mechanism 8580.91

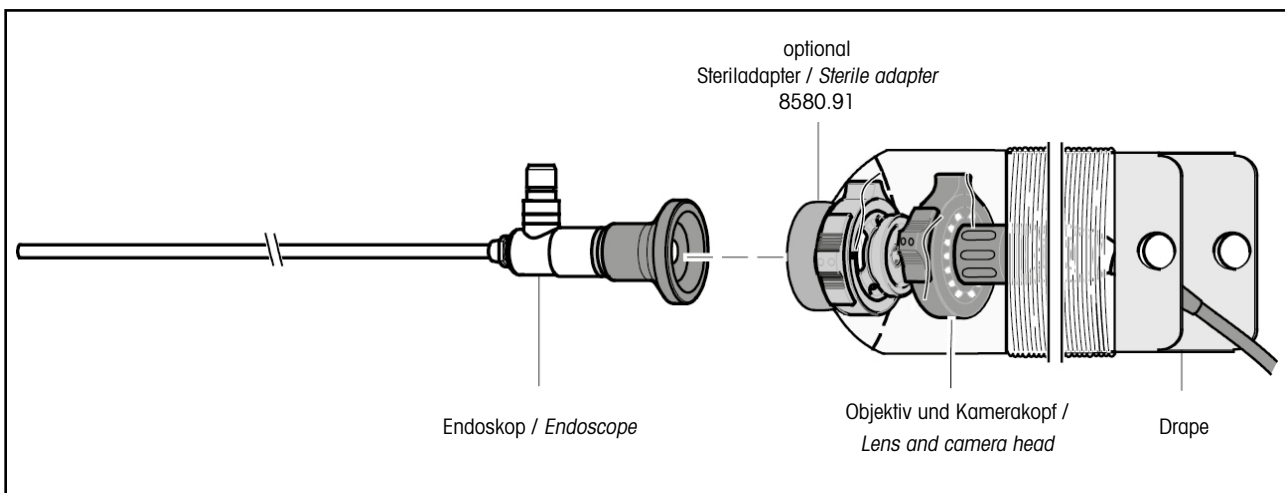

2





Trocar Sleeves 2 mm

Trocarhülsen 2 mm

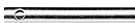
3

Trocarhülse mit Insufflations-Anschluss					Trokar, Spitze dreikantig 
<i>Trocar sleeve with insufflation connector</i>		Durchlass / Capacity	Typen / Types	<i>Trocar, pyramidal tip</i>	
Metallrohr, glatt, distal gerade					8309.121
					
<i>Metal sleeve, standard, straight distal tip</i>	NL / WL 100 mm	2 mm	8309.014		8309.123







Trocarhülse					Trokar, Spitze dreikantig 
<i>Trocar sleeve</i>		Durchlass / Capacity	Typen / Types	<i>Trocar, pyramidal tip</i>	
Kunststoffrohr mit Gewinde, distal gerade					
					
<i>Plastic sleeve with retaining thread, straight distal tip</i>	NL / WL 60 mm	2 mm	8309.072		8309.121

Spare sealing caps, PACK=10 PCS 88.01

Ersatz-Dichtungskappen, VE=10 ST 88.01

Trocar Sleeves 3.5 mm

Trocarhülsen 3,5 mm

<p>RIWO-ART-Trocarhülsen mit Magnet-Kugel-Ventil mit Insufflationshahn</p>  <p><i>RIWO-ART trocar sleeves with magnetic-ball-valve with insufflation tap</i></p>		<p>Durchlass / Capacity</p> <p>Typen / Types</p>		<p>Trocar, Spitze kegelig-stumpf</p>  <p><i>Trocar, blunt conical tip</i></p>	<p>Trocar, Spitze dreieckig</p>  <p><i>Trocar, pyramidal tip</i></p>
<p>Metallrohr, glatt, distal gerade</p>  <p><i>Metal sleeve, standard, straight distal tip</i></p>	<p>NL / WL 100 mm</p>	<p>3.5 mm</p>	<p>8903.014</p>	<p>8903.103</p>	<p>8903.123</p>
<p>Kunststoffrohr mit Gewinde, distal gerade</p>  <p><i>Plastic sleeve with retaining thread, straight distal tip</i></p>	<p>NL / WL 60 mm</p>	<p>3.5 mm</p>	<p>8903.072</p>	<p>8903.101</p>	<p>8903.121</p>
<p>Kunststoffrohr mit Gewinde, distal gerade</p>  <p><i>Plastic sleeve with retaining thread, straight distal tip</i></p>	<p>NL / WL 100 mm</p>	<p>3.5 mm</p>	<p>8903.034</p>	<p>8903.103</p>	<p>8903.123</p>

3

Spare ball, 1 piece, capacity Ø 3.5 mm - 5.5 mm 8921.901
 Spare o-rings, PACK=10 PCS,
 capacity Ø 3.5 mm - 5.5 mm 8921.951
 Spare sealing caps, PACK=10 PCS,
 capacity 3.5 mm, red 89.01
 Spare plug, PACK=5 PCS 896.0002







Ersatzkugel, 1 Stück, Durchlass Ø 3,5 mm - 5,5 mm 8921.901
 Ersatz-O-Ringe, VE=10 ST,
 Durchlass Ø 3,5 mm - 5,5 mm 8921.951
 Ersatz-Dichtungskappen, VE=10 ST,
 Durchlass 3,5 mm, rot 89.01
 Ersatz-Hahnkükten, VE=5 ST 896.0002

<p>Kunststoff-Trocarhülse</p>  <p><i>Plastic trocar sleeve</i></p>		<p>Durchlass / Capacity</p> <p>Type / Type</p>		<p>Trocar, kugelig</p>  <p><i>Trocar, ball shaped</i></p>
<p>Schaft mit distalem Schraubanker</p>  <p><i>Distal straight with anchor</i></p>	<p>NL / WL 40 mm</p>	<p>3.5 mm</p>	<p>8929.223</p>	<p>8929.2215</p>

Trocar Sleeves 5.5 mm

Trocarhülsen 5,5 mm

3









RIWO-ART-Trocarhülsen mit Magnet-Kugel-Ventil mit Insufflationshahn 		Durchlass / Capacity	Typen / Types	Trocar, Spitze kegelig-stumpf	Trocar, Spitze kegelig-spitz	Trocar, Spitze dreikantig
RIWO-ART trocar sleeves with magnetic-ball-valve with insufflation tap				Trocar, blunt conical tip	Trocar, conical tip	Trocar, pyramidal tip
Metallrohr, glatt, distal gerade 	NL / WL 100 mm	5.5 mm	8921.014	8921.103	8921.113	8921.123
Metal sleeve, standard, straight distal tip	NL / WL 150 mm	5.5 mm	8921.016	8921.105	8921.115	8921.125
Metallrohr, glatt, distal abgeschrägt 	NL / WL 100 mm	5.5 mm	8921.013	8921.103	8921.113	8921.123
Metal sleeve, standard, oblique distal tip						
Metallrohr mit Gewinde, distal gerade 	NL / WL 100 mm	5.5 mm	8921.024	8921.103	8921.113	8921.123
Metal with retaining thread, straight distal tip	NL / WL 150 mm	5.5 mm	8921.026	8921.105	8921.115	8921.125
Metallrohr mit Gewinde, distal abgeschrägt 	NL / WL 100 mm	5.5 mm	8921.023	8921.103	8921.113	8921.123
Metal sleeve with retaining thread, oblique distal tip						
Kunststoffrohr mit Gewinde, distal gerade 	NL / WL 100 mm	5.5 mm	8921.034	8921.103	8921.113	8921.123
Plastic sleeve with retaining thread, straight distal tip						

Spare ball, 1 piece, capacity Ø 3.5 mm - 5.5 mm 8921.901
 Spare o-rings, PACK=10 PCS, capacity Ø 3.5 mm - 5.5 mm. 8921.951
 Spare sealing caps, PACK=10 PCS,
 capacity 5.5 mm, blue 89.02
 Spare plug 896.0002

Ersatzkugel, 1 Stück, Durchlass Ø 3,5 mm - 5,5 mm..... 8921.901
 Ersatz-O-Ringe, VE=10 ST, Durchlass Ø 3,5 mm - 5,5 mm .. 8921.951
 Ersatz-Dichtungskappen, VE=10 ST,
 Durchlass 5,5 mm, blau..... 89.02
 Ersatz-Hahnküken 896.0002

Trocar Sleeves 5.5 mm

Trokarhülsen 5,5 mm

RIWO-ART-Trokarhülsen mit Magnet-Kugel-Ventil				Trokar, Spitze kegelig-stumpf	Trokar, Spitze kegelig-spitz	Trokar, Spitze dreikantig
						
<i>RIWO-ART trocar sleeves with magnetic-ball-valve</i>		Durchlass / Capacity	Typen / Types	<i>Trocar, blunt conical tip</i>	<i>Trocar, conical tip</i>	<i>Trocar, pyramidal tip</i>
Metallrohr, glatt, distal gerade	NL / WL 60 mm	5.5 mm	8921.052	8921.101	8921.111	8921.121
	NL / WL 100 mm	5.5 mm	8921.054	8921.103	8921.113	8921.123
Metallrohr, glatt, distal abgeschrägt	NL / WL 60 mm	5.5 mm	8921.051	8921.101	8921.111	8921.121
	NL / WL 100 mm	5.5 mm	8921.053	8921.103	8921.113	8921.123
Metallrohr mit Gewinde, distal gerade	NL / WL 60 mm	5.5 mm	8921.062	8921.101	8921.111	8921.121
	NL / WL 60 mm	5.5 mm	8921.061	8921.101	8921.111	8921.121
Metallrohr mit Gewinde, distal abgeschrägt	NL / WL 60 mm	5.5 mm	8921.061	8921.101	8921.111	8921.121
	NL / WL 60 mm	5.5 mm	8921.072	8921.101	8921.111	8921.121
Kunststoffrohr mit Gewinde, distal gerade	NL / WL 60 mm	5.5 mm	8921.072	8921.101	8921.111	8921.121
						

Spare ball, 1 piece, capacity Ø 3.5 mm - 5.5 mm.....8921.901
 Spare o-rings, PACK=10 PCS, capacity Ø 3.5 mm - 5.5 mm.8921.951
 Spare sealing caps, PACK=10 PCS,
 capacity 5.5 mm, blue 89.02

Ersatzkugel, 1 Stück, Durchlass Ø 3,5 mm - 5,5 mm..... 8921.901
 Ersatz-O-Ringe, VE=10 ST, Durchlass Ø 3,5 mm - 5,5 mm..8921.951
 Ersatz-Dichtungskappen, VE=10 ST,
 Durchlass 5,5 mm, blau..... 89.02

TROTEC Protective Trocars
for 5.5 mm trocar sleeves

TROTEC Schutztrokare
für Trokarhülsen 5,5 mm

3

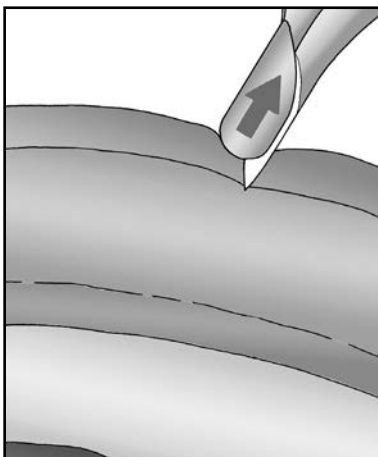
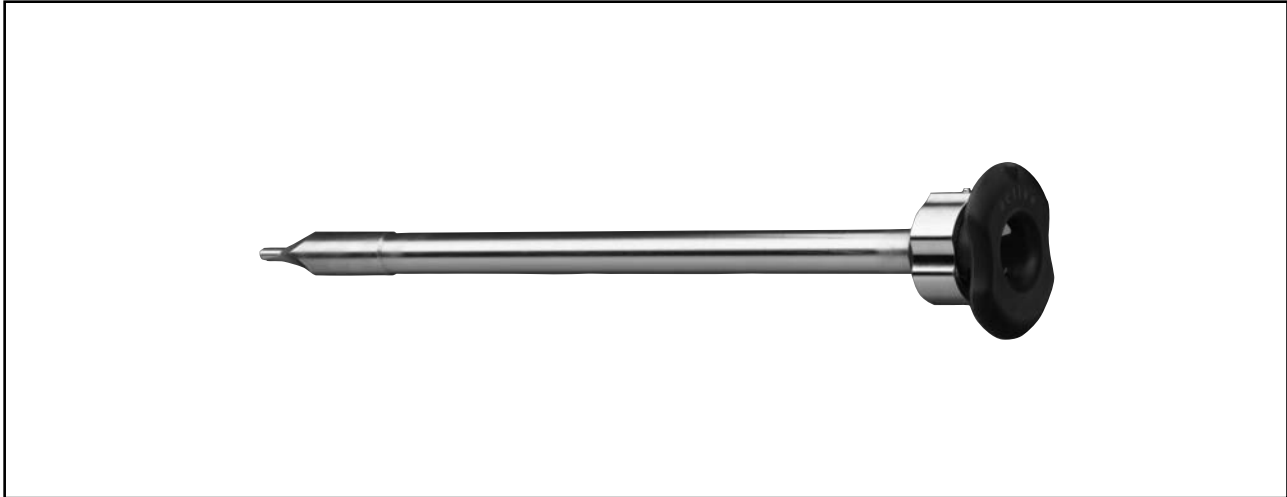

Schutzdorn schiebt sich automatisch durch Kontakt mit der Bauchdecke in die Kanüle zurück.

The protective rod retracts automatically into the cannula when it makes contact with the abdominal wall.

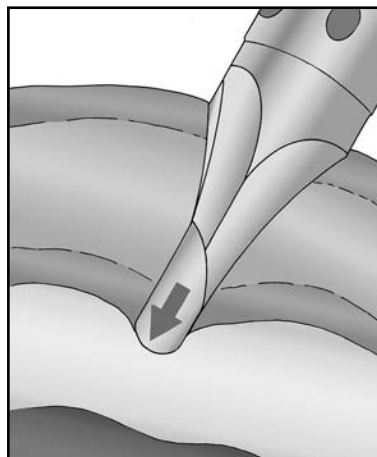

Unmittelbar nach Durchdringen des Peritoneums schnell der Schutzdorn in das freie Abdomen.

Immediately after penetrating the peritoneum, the protective rod snaps back into the free abdominal cavity.

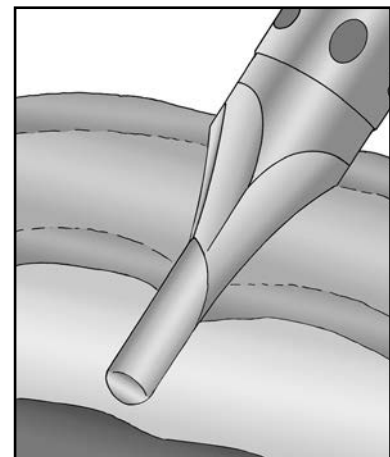





Der weit nach distal positionierte atraumatische Schutzdorn verhindert die Perforation von Organen und Gefäßen.

The extreme distal position of the atraumatic protective rod prevents perforation of organs and vessels.

TROTEC-Trokar bestehend aus: TROTEC trocar consisting of:			TROTEC-Trokar komplett TROTEC trocar complete	Für RIWO ART-Trokarhülse mit: For RIWO ART trocar sleeves: (BDE 34+35)	
Schaft mit Kanülen- spitze, kegelig / Sheath with conical cannula tip	Schaft mit Lanzetten- spitze, zweikantig / Sheath with two- edged lancet tip	Griff mit federndem Schutzstab / Handle with spring- mounted protective rod		NL mm WL mm	Ø mm
8921.132		8923.135	8921.131	100 mm	5.5 mm
	8921.134	8923.135	8921.133	100 mm	5.5 mm

*Flexible Trocar Sleeves 5.5 mm
for curved instruments*

*Flexible Trokarhülsen 5,5 mm
für gebogene Instrumente*

 <p>AUTOCLAVE 134° C / 273° F</p>				<p>Trokar, kegelig stumpf</p> 	<p>Trokar, kegelig spitz</p> 	<p>Trokar, dreikantig</p> 	<p>Trokar, kugelig</p> 
	NL / WL	Durchlass / Capacity	Typen / Types	<i>Trocar,</i> blunt conical tip	<i>Trocar,</i> conical tip	<i>Trocar,</i> pyramidal tip	<i>Trocar,</i> ball shaped
<p>Kunststoffschaft mit Gewinde, distal gerade, inkl. Membranventil 89.103 (VE=10 ST)</p>	62 mm	5.8 mm	8905.331	8905.3311	8905.3312	8905.3313	8905.3315
	102 mm	5.8 mm	8905.351	8905.3511	8905.3512	8905.3513	8905.3515
	178 mm	5.8 mm	8905371	89053711	-	-	-
<p>Plastic sheath with retaining thread, straight distal tip, incl. membrane valves 89.103 (PACK=10 PCS)</p>							

3

Membrane valves, yellow, PACK=10 PCS.....89.103

Membran-Ventil, gelb, VE=10 ST89.103

Trocar Sleeves 5.5 mm

plastic with membrane seal

Trokarhülsen 5,5 mm

Kunststoff mit Dichtmembrane



AUTOCLAVE
134° C / 273° F

Trokar,
kegelig stumpf



Trokar,
kegelig spitz



Trokar,
Spitze dreikantig



	NL / WL	Durchlass / Capacity	mit Hahn / with cock	Typen / Types	Trocar, blunt conical tip	Trocar, conical tip	Trocar, pyramidal tip
Selbsthaltende Kunststofftrokarhülse, autoklavierbar, inkl. Membranventil 89.103 (VE=10 ST) Self retaining plastic trocar sleeve, autoclavable, incl. membrane valve 89.103 (PACK=10 PCS)	65 mm	5.5 mm	•	8919.333	8919.3311	8919.3312	8919.3313
		5.5 mm		8919.331			
	105 mm	5.5 mm	•	8919.353	8919.3511	8919.3512	8919.3513
		5.5 mm		8919.351			

Membrane valves, yellow, PACK=10 PCS..... 89.103



Spare plug, PACK= 5 896.0002

Membran-Ventil, gelb, VE=10 ST 89.103

Ersatz-Hahnküken, VE=5 ST 896.0002

Trocar Sleeves 5.5 mm





Trokarhülsen 5,5 mm

<p>Flexible Trokarhülse, Kunststoff</p> 			<p>Trokar, Spitze stumpf, kegelig</p> 	
Flexible trocar sleeve, plastic	NL / WL	Durchlass / Capacity	Type / Type	Trocar, blunt, conical tip
<p>distal abgechrägt</p>  <p>oblique distal tip</p>	75 mm	5.5 mm	8906.051	8906.151

3

Trocar Sleeves 10 mm with insufflation tap

Trocarhülsen 10 mm mit Insufflationshahn





RIWO-ART-Trocarhülsen mit Magnet-Kugel-Ventil				Trocar, Spitze kegelig-stumpf	Trocar, Spitze kegelig-spitz	Trocar, Spitze dreikantig	
<i>RIWO-ART trocar sleeves with magnetic-ball-valve</i>		Durchlass / Capacity	Typen / Types	<i>Trocar, blunt conical tip</i>	<i>Trocar, conical tip</i>	<i>Trocar, pyramidal tip</i>	
Metallrohr, glatt, distal gerade		NL / WL 100 mm	10 mm	8923.014	8923.103	8923.113	8923.123
<i>Metal sleeve, standard, straight distal tip</i>		NL / WL 150 mm	10 mm	8923.016	-	8923.115	8923.125
Metallrohr, glatt, distal abgeschrägt		NL / WL 100 mm	10 mm	8923.013	8923.103	8923.113	8923.123
<i>Metal sleeve, standard, oblique distal tip</i>							
Metallrohr mit Gewinde, distal gerade		NL / WL 100 mm	10 mm	8923.024	8923.103	8923.113	8923.123
<i>Metal with retaining thread, straight distal tip</i>		NL / WL 150 mm	10 mm	8923.026	-	8923.115	8923.125
Metallrohr mit Gewinde, distal abgeschrägt		NL / WL 100 mm	10 mm	8923.023	8923.103	8923.113	8923.123
<i>Metal sleeve with retaining thread, oblique distal tip</i>							

Spare ball, 1 piece, capacity Ø 7 mm - 12.5 mm 8923.901
 Spare o-rings, PACK=10, capacity Ø 7 mm - 12.5 mm 8923.951
 Spare sealing caps, PACK=10 PCS,
 capacity 10 mm, red 89.08
 Spare plug, PACK=5 PCS 896.0002

Ersatzkugel, 1 Stück, Durchlass Ø 7 mm - 12,5 mm 8923.901
 Ersatz-O-Ringe, VE=10 ST, Durchlass Ø 7 mm - 12,5 mm ... 8923.951
 Ersatz-Dichtungskappen, VE=10 ST,
 Durchlass 10 mm, rot 89.08
 Ersatz-Hahnküken, VE=5 ST 896.0002

TROTEC protective trocars

TROTEC Schutztrokare



TROTEC-Trocar bestehend aus: TROTEC trocar consisting of:				Für RIWO ART-Trocarhülse mit: For RIWO ART trocar sleeves:	
			TROTEC-Trocar komplett TROTEC trocar complete		
Schaft mit Kanülen- spitze, kegelig / Sheath with conical cannula tip	Schaft mit Lanzetten- spitze, zweikantig / Sheath with two- edged lancet tip	Griff mit federndem Schutzstab / Handle with spring- mounted protective rod		NL WL	Ø
8923.132		8923.135	8923.131	100 mm	10 mm
	8923.134	8923.135	8923.133	100 mm	10 mm

High-Flow Trocar Sleeves

with high flow hose connection
10 mm

High-Flow-Trokarhülsen

mit High-Flow-Insufflationsschlauch-Anschluss
10 mm

RIWO-ART-Trokarhülsen mit Magnet-Kugel-Ventil,				Trokar, Spitze kegelig-stumpf	Trokar, Spitze kegelig-spitz	Trokar, Spitze dreikantig
<i>RIWO-ART trocar sleeves with magnetic-ball-valve</i>				<i>Trocar, blunt conical tip</i>	<i>Trocar, conical tip</i>	<i>Trocar, pyramidal tip</i>
	Durchlass / Capacity	Typen / Types				
 Metallrohr, glatt, distal gerade  Metal sleeve, standard, straight distal tip	NL / WL 100 mm	10 mm	8923.042	8923.103	8923.113	8923.123

VARIO-PORT reducing adapter, PACK=5 PCS
for reduction from
Ø 10 mm to Ø 5.5 mm and
Ø 12.5 mm to Ø 5.5 mm 8923.802



VARIO-PORT-Reduzieradapter, VE=5 ST
zur Reduktion von
Ø 10 mm auf Ø 5,5 mm und
Ø 12,5 mm auf Ø 5,5 mm 8923.802



Spare ball, 1 piece, capacity Ø 7 mm - 12.5 mm 8923.901
Spare o-rings, PACK=10 PCS, capacity Ø 7 mm - 12.5 mm .8923.951
Spare sealing caps, PACK=10 PCS,
capacity 10 mm, red..... 89.08

Ersatzkugel, 1 Stück, Durchlass Ø 7 mm - 12,5 mm 8923.901
Ersatz-O-Ringe, VE=10 ST, Ø 7 mm - 12,5 mm 8923.951
Ersatz-Dichtungskappen, VE=10 ST,
Durchlass 10 mm,rot 89.08

Trocar Sleeves 10 mm







Trokarhülsen 10 mm

3

<p>Flexible Trokarhülse, Kunststoff</p> 				<p>Trokar, Spitze stumpf, kegelig</p> 
<p>Flexible trocar sleeve, plastic</p>	NL / WL	Durchlass / Capacity	Type / Type	<p>Trocar, blunt, conical tip</p>
<p>distal gerade</p>  <p>straight distal tip</p>	60 mm	10 mm	8906.011	8906.111

Trocar Sleeves 12.5 mm
with insufflation tap

Trocarhülsen 12,5 mm
mit Insufflationshahn



RIWO-ART-Trocarhülsen mit Magnet-Kugel-Ventil				Trocar, Spitze kegelig-stumpf	Trocar, Spitze kegelig-spitz	Trocar, Spitze dreikantig
						
<i>RIWO-ART trocar sleeves with magnetic-ball-valve</i>		Durchlass / Capacity	Typen / Types	<i>Trocar, blunt conical tip</i>	<i>Trocar, conical tip</i>	<i>Trocar, pyramidal tip</i>
Metallrohr, glatt, distal gerade 	NL / WL 100 mm	12.5 mm	8924.014	8924.103	8924.113	8924.123
Metal sleeve, standard, straight distal tip	NL / WL 150 mm	12.5 mm	8924.016	-	8924.115	8924.125
Metallrohr, glatt, distal abgeschrägt 	NL / WL 100 mm	12.5 mm	8924.013	8924.103	8924.113	8924.123
Metal sleeve, standard, oblique distal tip						
Metallrohr mit Gewinde, distal gerade 	NL / WL 150 mm	12.5 mm	8924.026	-	8924.115	8924.125
Metal with retaining thread, straight distal tip						

3

VARIO-PORT reducing adapter, PACK=5 PCS
for reduction from
Ø 10 mm to Ø 5.5 mm and
Ø 12.5 mm to Ø 5.5 mm 8923.802
Ø 12.5 mm to Ø 10 mm 8924.802





VARIO-PORT-Reduzieradapter, VE=5 ST
zur Reduktion von
Ø 10 mm auf Ø 5,5 mm und
Ø 12,5 mm auf Ø 5,5 mm..... 8923.802
Ø 12,5 mm auf Ø 10 mm..... 8924.802

TROTEC-Trocar bestehend aus: <i>TROTEC trocar consisting of:</i>			Für RIWO ART-Trocarhülse mit: <i>For RIWO ART trocar sleeves:</i>	
 Schaft mit Lanzettenspitze, zweikantig / <i>Sheath with two-edged lancet tip</i>	 Griff mit federndem Schutzstab / <i>Handle with spring-mounted protective rod</i>	TROTEC-Trocar komplett <i>TROTEC trocar complete</i>		
8924.134	8923.135	8924.133	NL WL 100 mm	Ø 12.5 mm

Trocar Sleeve 12.5 mm

Trokarhülse 12,5 mm

<p>Flexible Trokarhülse, Kunststoff</p> 				<p>Trokar, Spitze stumpf, kegelig</p> 
<p>Flexible trocar sleeve, plastic</p>	NL / WL	Durchlass / Capacity	Type / Type	<p>Trocar, blunt, conical tip</p>
<p>distal gerade</p>  <p>straight distal tip</p>	60 mm	12.5 mm	8906.031	8906.131

3

*Dilatation
and Extraction Instruments*
5.5 to 10 / 10 to 12.5 mm

Dilatations-
und Extraktions-Instrumente
5,5 bis 10 / 10 bis 12,5 mm

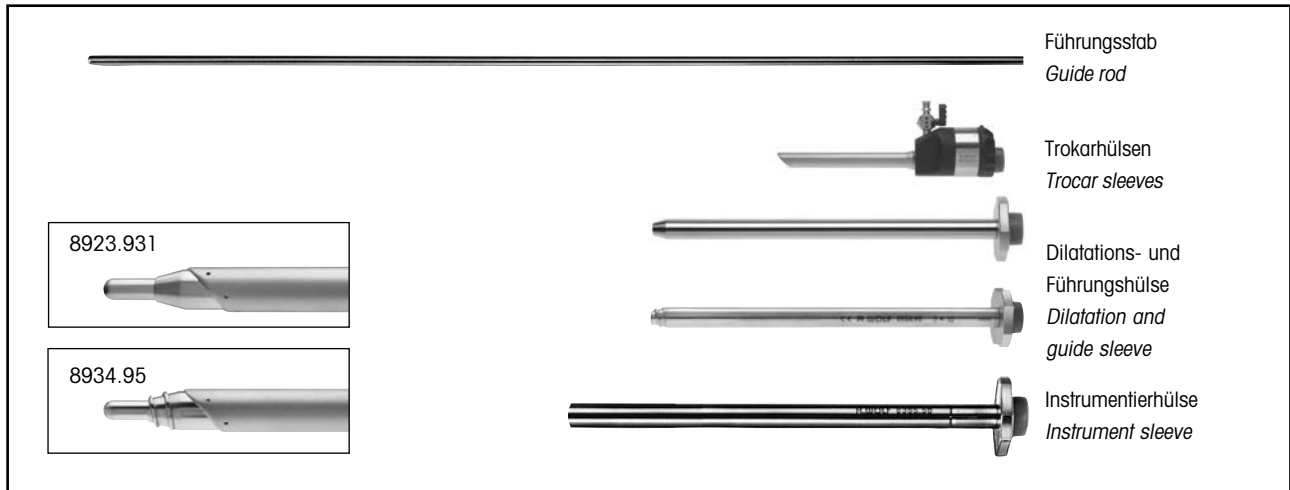

Zur Erweiterung einer Inzision <i>To extend an incision</i>	Führungsstab <i>Guide rod</i>	Trokarhülse <i>Trocar sleeve</i>	Dilatations- und Führungshülse <i>Dilatation and guide sleeve</i>
3.5 mm bis / to 5.5 mm	-	8921.013	-
5.5 mm bis / to 10 mm <i>(5.0 mm bis / to 10 mm)</i>	8923.921 (8934.951)	8923.013	8923.931 (8934.95)
10 mm bis / to 12.5 mm <i>5 mm bis / to 12.5 mm</i>	8943.901	8924.013	-

Instrumentierhülse, Extraktor und Reduzierhülse <i>Instrument sleeve, extractor and reducing sleeve</i>
8383.78*
8385.50**
8941.901*** 8941.951****

for sealed application of

- * 3,5 mm instruments in the 5.5 mm trocar sleeve
- ** 5 mm instruments in the 12.5 mm trocar sleeve
- *** 10 mm instruments in the 12.5 mm trocar sleeve
- **** 5 mm instruments in the 12.5 mm trocar sleeve and for extraction of the appendix.

zur abgedichteten Anwendung von

- * 3,5-mm-Instrumenten in der 5,5-mm-Trokarhülse .
- ** 5-mm-Instrumenten in der 12,5-mm-Trokarhülse
- *** 10-mm-Instrumenten in der 12,5-mm-Trokarhülse
- **** 5-mm-Instrumenten in der 12,5-mm-Trokarhülse sowie zur Appendixextraktion.

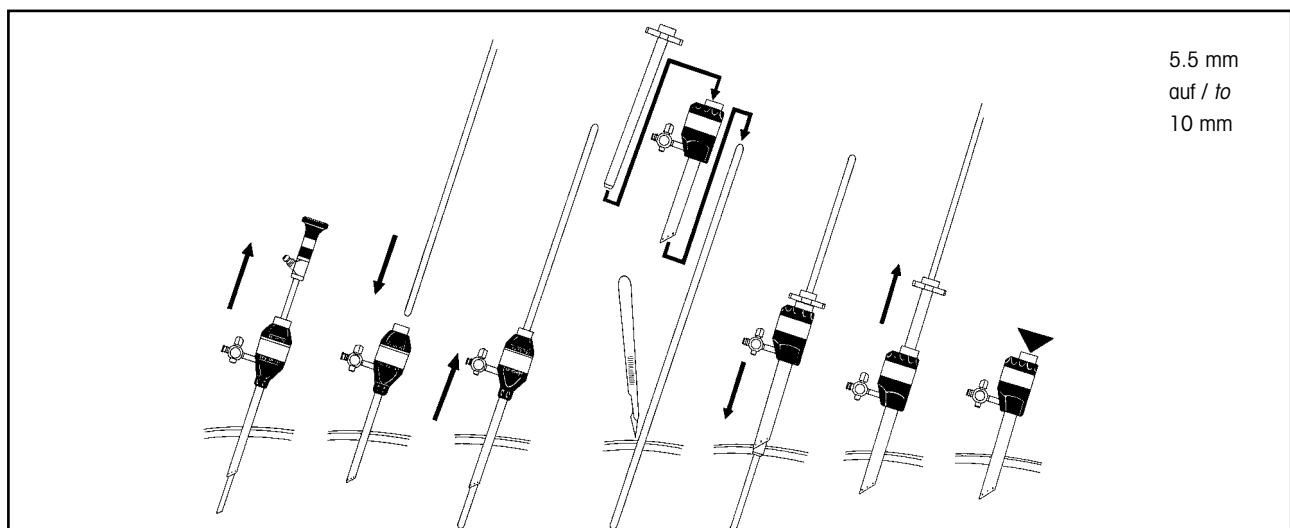

Reducing Sleeves

for RIWO-ART trocar sleeves

Reduzierhülsen

für RIWO-ART-Trokarhülsen

3

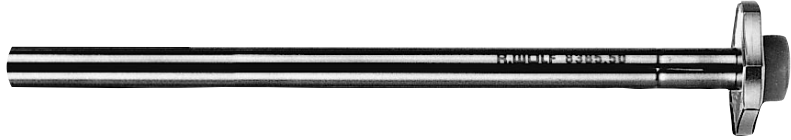

	Außen-Ø Outer Ø	NL / WL	für Instrumente for instrument sizes	Typen / Types
5.5 / 3.5 mm Reduzierhülse* Reducing sleeve*	5.5 mm	160 mm	3.5 mm	8383.78
10.0 / 5.5 mm Instrumentierhülse und Extraktor* Instrument sleeve and extractor*	10 mm	170 mm	5.5 mm	8385.50
12.5 / 10.0 mm Reduzierhülse** Reducing sleeve**	12.5 mm	180 mm	10 mm	8941.901
12.5 / 5.5 mm Reduzierhülse* Reducing sleeve*	12.5 mm	180 mm	5.5 mm	8941.951

* Spare sealing caps, PACK=10 PCS 89.02
 ** Spare sealing caps, PACK=10 PCS 89.08





* Ersatz-Dichtungskappen, VE=10 ST 89.02
 ** Ersatz-Dichtungskappen, VE=10 ST 89.08







	Reduktion von Reduction from	auf / to	Typen / Types
VARIO-PORT-Reduzier- adapter, 5 ST VARIO-PORT reducing adapter, PACK=5 PCS	Ø 7 mm Ø 10 mm Ø 12.5 mm	Ø 5.5 mm	8923.802
	Ø 12.5 mm	Ø 10 mm	8924.802

ERAGON modular
micro
modular instruments 2 mm

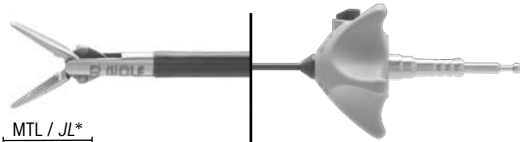
ERAGON modular
micro
modulare Instrumente 2 mm

<p>ERAGON axial</p> <p>Alle Innenteile und Schaftröhre sind ebenfalls mit ERAGONaxial kombinierbar. <i>All jaw inserts and sheaths can also be combined with ERAGONaxial.</i></p>	Griffvarianten / Handle type				<p>Drehradaufsatz, ERAGONaxial Knob attachment, ERAGONaxial</p>  <p>autoklavierbar / autoclavable</p>
	 <p>mit Sperre, drehbar with locking mechanism, rotatable</p>	 <p>HF / mono ohne Sperre, drehbar without locking mechanism, rotatable</p>	 <p>HF / mono mit Sperre, drehbar with locking mechanism, rotatable</p>	 <p>mit Sperre, nicht drehbar with locking mechanism, not rotatable</p>	
Typen / Types	83930082	83930083	83930084	83930085	8988

<p>Innenteil mit isoliertem Schaftröhr <i>Jaw insert with insulated sheath tube</i></p>  <p>MTL / JL*</p>	 <p>HF / mono</p>	<p>Griffvarianten / Handle type</p> <p>mit Sperre, drehbar with locking mechanism, rotatable</p>	<p>Komplett-Instrument</p> <ul style="list-style-type: none"> • Innenteil mit Schaftröhr • Handgriff <p>Complete instrument</p> <ul style="list-style-type: none"> • Jaw insert with sheath tube • Handle 	
				<p>NL / WL 240 mm</p>
 <p>Dissektor, gerade, doppelbeweglich MTL= 7 mm Dissector, straight, double jaw action, JL= 7 mm</p>	8388201	●	●	83882017
 <p>Atraumatische Greifzange, gefensternt, doppelbeweglich MTL= 7 mm Atraumatic grasping forceps, fenestrated, double jaw action JL= 7 mm</p>	8388202	●	●	83882027
 <p>Universal-Fasszange, doppelbeweglich MTL= 7 mm Universal grasping forceps, double jaw action JL= 7 mm</p>	8388203	●	●	83882037

* JL = Jaw length when jaws closed (approximate measurements)





* MTL = Maulteillänge bei geschlossenem Maulteil (gerundete Angaben)







also: Irrigation adapter see overleaf.
HF connecting cable see page BDE 163.

hierzu: Spüladapter siehe Rückseite.
HF-Anschlusskabel siehe Blatt BDE 163.

ERAGON modular mini
modular instruments 3.5 mm

ERAGON modular mini
modulare Instrumente 3,5 mm

<p>ERAGON axial</p> <p>Alle Innenteile und Schaffrohre sind ebenfalls mit ERAGONaxial kombinierbar. <i>All jaw inserts and sheaths can also be combined with ERAGONaxial.</i></p>	Griffvarianten / Handle type				Drehradaufsatz, ERAGONaxial Knob attachment, ERAGONaxial
					
Typen / Types	83930082	83930083	83930084	83930085	8988

<p>Innenteil Jaw insert</p>  <p>MTL / JL*</p>	Schaffrohr, isoliert Sheath tube, insulated		Griffvarianten / Handle type		<p>Komplett-Instrument</p> <ul style="list-style-type: none"> • Innenteil • Schaffrohr • Handgriff <p>Complete instrument</p> <ul style="list-style-type: none"> • Jaw insert • Sheath • Handle
				mit Sperre, drehbar with locking mechanism, rotatable	
Typen / Types	8390933	8391933	83930074		Typen / Types
	8390221	●		●	83902217
<p>Greif- und Dissektionszange, lang, feine Spitze, doppelbeweglich, MTL= 18 mm Grasping and dissecting forceps, long, fine tip, double jaw action JL= 18 mm</p>	8391221		●	●	83912217
	8390222	●		●	83902227
<p>Greif- und Dissektionszange, kurz, feine Spitze, doppelbeweglich, MTL= 14 mm Grasping and dissecting forceps, short, fine tip, double jaw action JL= 14 mm</p>	8391222		●	●	83912227
	8390223	●		●	83902237
<p>Greif- und Dissektionszange, rechts abgewinkelt, doppelbeweglich, MTL= 14 mm Grasping and dissecting forceps, curved right, double jaw action JL= 14 mm</p>	8391223		●	●	83912237

* JL = Jaw length when jaws closed (approximate measurements)





* MTL = Maulteillänge bei geschlossenem Maulteil (gerundete Angaben)





HF connecting cable see page BDE 163.

HF-Anschlusskabel siehe Blatt BDE 163.

ERAGON modular
mini
modular instruments 3.5 mm

ERAGON modular
mini
modulare Instrumente 3,5 mm

<p>ERAGONaxial</p> <p>Alle Innenteile und Schaffrohre sind ebenfalls mit ERAGONaxial kombinierbar. <i>All jaw inserts and sheaths can also be combined with ERAGONaxial.</i></p>	Griffvarianten / Handle type				<p>Drehradaufsatz, ERAGONaxial Knob attachment, ERAGONaxial</p>  <p>autoklavierbar / autoclavable</p>
	 <p>mit Sperre, drehbar with locking mechanism, rotatable</p>	 <p>HF / mono ohne Sperre, drehbar without locking mechanism, rotatable</p>	 <p>HF / mono mit Sperre, drehbar with locking mechanism, rotatable</p>	 <p>mit Sperre, nicht drehbar with locking mechanism, not rotatable</p>	
Typen / Types	83930082	83930083	83930084	83930085	8988

<p>Innenteil Jaw insert</p>  <p>MTL / JL*</p>	Schaffrohr, isoliert Sheath tube, insulated		Griffvarianten / Handle type		<p>Komplett-Instrument</p> <ul style="list-style-type: none"> • Innenteil • Schaffrohr • Handgriff <p>Complete instrument</p> <ul style="list-style-type: none"> • Jaw insert • Sheath • Handle
	NL / WL 240 mm	NL / WL 330 mm	HF / mono	mit Sperre, drehbar with locking mechanism, rotatable	
Typen / Types	8390933	8391933	83930074		Typen / Types
 <p>8390207</p>	●				83902077
<p>Greif- und Dissektionszange, links gebogen, doppelbeweglich, MTL= 15 mm <i>Grasping and dissecting forceps, long, fine tip, double jaw action, JL= 15mm</i></p> <p>8391207</p>		●			83912077
 <p>8390216</p>	●				83902167
<p>Doppellöffelzange, nach Hürtsen MTL= 12 mm <i>Double-spoon forceps, by Hürtsen, JL= 12 mm</i></p> <p>8391216</p>		●			83912167
 <p>8390217</p>	●				83902177
<p>Stanze nach Friedel, MTL= 10 mm <i>Punch by Friedel, JL= 10 mm</i></p> <p>8391217</p>		●			83912177

* JL = Jaw length when jaws closed (approximate measurements)

* MTL = Maulteillänge bei geschlossenem Maulteil (gerundete Angaben)

HF connecting cable see page BDE 163.



HF-Anschlusskabel siehe Blatt BDE 163.

ERAGON modular
mini







modular instruments 3.5 mm

ERAGON modular
mini

modulare Instrumente 3,5 mm

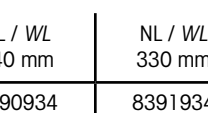
<p>ERAGON axial</p> <p>Alle Innenteile und Schaftröhre sind ebenfalls mit ERAGONaxial kombinierbar. <i>All jaw inserts and sheaths can also be combined with ERAGONaxial.</i></p>	Griffvarianten / Handle type		<p>Drehradaufsatz, ERAGONaxial Knob attachment, ERAGONaxial</p>  <p>autoklavierbar / autoclavable</p>
	 <p>mit Sperre, drehbar <i>without locking mechanism, rotatable</i></p>	 <p>mit Sperre, nicht drehbar <i>with locking mechanism, not rotatable</i></p>	
Typen / Types	83930082	83930085	8988

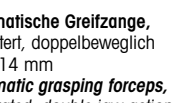
4

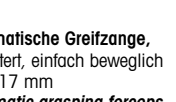
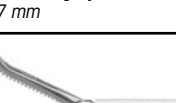
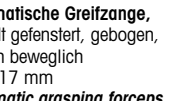



<p>Innenteil Jaw insert</p>  <p>MTL / JL*</p>	Schaftröhre, unisoliert Sheath tube, uninsulated		Griffvarianten / Handle type		<p>Komplett-Instrument</p> <ul style="list-style-type: none"> • Innenteil • Schaftröhre • Handgriff <p>Complete instrument</p> <ul style="list-style-type: none"> • Jaw insert • Sheath • Handle
	 <p>NL / WL 240 mm</p>	 <p>NL / WL 330 mm</p>	 <p>mit Sperre, drehbar <i>with locking mechanism, rotatable</i></p>		
Typen / Types	8390934	8391934	83930072		Typen / Types
 <p>Atraumatische Greifzange, gefenestert, doppelbeweglich MTL= 14 mm Atraumatic grasping forceps, fenestrated, double jaw action JL= 14 mm</p>	8390208	●	●	●	83902087
 <p>Atraumatische Greifzange, gefenestert, einfach beweglich MTL= 17 mm Atraumatic grasping forceps, fenestrated, single jaw action JL= 17 mm</p>	8391208	●	●	●	83912087
 <p>Atraumatische Greifzange, gefenestert, einfach beweglich MTL= 17 mm Atraumatic grasping forceps, fenestrated, single jaw action JL= 17 mm</p>	8390218	●	●	●	83902187
 <p>Atraumatische Greifzange, doppelt gefenestert, gebogen, einfach beweglich MTL= 17 mm Atraumatic grasping forceps, double fenestrated, curved, single jaw action JL= 17 mm</p>	8391218	●	●	●	83912187
 <p>Atraumatische Greifzange, doppelt gefenestert, gebogen, einfach beweglich MTL= 17 mm Atraumatic grasping forceps, double fenestrated, curved, single jaw action JL= 17 mm</p>	8390225	●	●	●	83902257
 <p>Atraumatische Greifzange, doppelt gefenestert, gebogen, einfach beweglich MTL= 17 mm Atraumatic grasping forceps, double fenestrated, curved, single jaw action JL= 17 mm</p>	8391225	●	●	●	83912257





* JL = Jaw length when jaws closed (approximate measurements)

* MTL = Maulteillänge bei geschlossenem Maulteil (gerundete Angaben)

ERAGON modular mini
modular instruments 3.5 mm

ERAGON modular mini
modulare Instrumente 3,5 mm

 Alle Innenteile und Schaftröhre sind ebenfalls mit ERAGONaxial kombinierbar. <i>All jaw inserts and sheaths can also be combined with ERAGONaxial.</i>	Griffvarianten / Handle type		Drehradaufsatz, ERAGONaxial <i>Knob attachment, ERAGONaxial</i>  autoklavierbar / autoclavable
	 mit Sperre, drehbar <i>without locking mechanism, rotatable</i>	 mit Sperre, nicht drehbar <i>with locking mechanism, not rotatable</i>	
Typen / Types	83930082	83930085	8988

Innenteil <i>Jaw insert</i>  MTL / JL	Schaftröhre, unisoliert <i>Sheath tube, uninsulated</i>		Griffvarianten / Handle type		Komplett-Instrument • Innenteil • Schaftröhre • Handgriff Complete instrument • Jaw insert • Sheath • Handle
	NL / WL 240 mm	NL / WL 330 mm	mit Sperre, drehbar <i>with locking mechanism, rotatable</i>		
Typen / Types	8390934	8391934	83930072		Typen / Types
 Atraumatische Greifzange, gefensternt, doppelbeweglich MTL= 19 mm Atraumatic grasping forceps, fenestrated, double jaw action JL= 19 mm	8390226	●		●	83902267
	8391226		●	●	83912267
 Greif- und Dissektionszange, doppelbeweglich MTL= 13 mm Grasping and dissecting forceps, double jaw action JL= 13 mm	8390219	●		●	83902197
	8391219		●	●	83912197
 Greif- und Dissektionszange, 2x4 Zähne, doppelbeweglich MTL= 14 mm Grasping and dissecting forceps, 2x4 teeth, double jaw action JL= 14 mm	8390220	●		●	83902207
	8391220		●	●	83912207

* JL = Jaw length when jaws closed (approximate measurements)

* MTL = Maulteillänge bei geschlossenem Maulteil (gerundete Angaben)

HF connecting cable see page BDE 163.



HF-Anschlusskabel siehe Blatt BDE 163.







ERAGON modular
mini

modular instruments 3.5 mm

ERAGON modular
mini

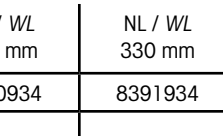
modulare Instrumente 3,5 mm

<p>ERAGON axial</p> <p>Alle Innenteile und Schaffrohre sind ebenfalls mit ERAGONaxial kombinierbar. <i>All jaw inserts and sheaths can also be combined with ERAGONaxial.</i></p>	Griffvarianten / Handle type		<p>Drehradaufsatz, ERAGONaxial Knob attachment, ERAGONaxial</p>  <p>autoklavierbar / autoclavable</p>
	 <p>mit Sperre, drehbar <i>without locking mechanism, rotatable</i></p>	 <p>mit Sperre, nicht drehbar <i>with locking mechanism, not rotatable</i></p>	
Typen / Types	83930082	83930085	8988



<p>Innenteil <i>Jaw insert</i></p>  <p>MTL / JL*</p>	Schaffrohr, unisoliert <i>Sheath tube, uninsulated</i>		Griffvarianten / Handle type	<p>Komplett-Instrument</p> <ul style="list-style-type: none"> • Innenteil • Schaffrohr • Handgriff <p>Complete instrument</p> <ul style="list-style-type: none"> • Jaw insert • Sheath • Handle
	 <p>NL / WL 240 mm</p>	 <p>NL / WL 330 mm</p>	 <p>mit Sperre, drehbar <i>with locking mechanism, rotatable</i></p>	
Typen / Types	8390934	8391934	83930072	Typen / Types
 <p>8390209</p>	●		●	83902097
<p>Universal-Greifzange, doppelbeweglich MTL= 14 mm Universal grasping forceps, double jaw action JL= 14 mm</p>	8391209		●	83912097
 <p>8390210</p>	●		●	83902107
<p>Greifzange "Babcock", doppelbeweglich MTL= 19 mm Grasping forceps "Babcock", double jaw action JL= 19 mm</p>	8391210		●	83912107

* JL = Jaw length when jaws closed (approximate measurements)

* MTL = Maulteillänge bei geschlossenem Maulteil (gerundete Angaben)

ERAGON modular
mini
modular instruments 3.5 mm

ERAGON modular
mini
modulare Instrumente 3,5 mm

Innenteil <i>Jaw insert</i>  MTL / JL*	Schaffrohr, isoliert <i>Sheath tube, insulated</i> NL / WL 240 mm NL / WL 330 mm		Griffvarianten / <i>Handle type</i> HF / mono 	Komplett- Instrument • Innenteil • Schaffrohr • Handgriff Complete instrument • Jaw insert • Sheath • Handle Typen / Types	
	Typen / Types	8390933	8391933		83930083
 SAXENA Pylorus-Spreizer , doppelbeweglich MTL= 14 mm SAXENA Pyloric spreader , double jaw action JL= 14 mm	8390228	●		●	83902287
	8391228		●	●	83912287

* JL = Jaw length when jaws closed (approximate measurements)

* MTL = Maulteillänge bei geschlossenem Maulteil (gerundete Angaben)



Optional:
Drehradaufsatz ERAGON axial, autoklavierbar 8988





Optional:
Knob attachment, ERAGON axial autoclavable 8988







HF connecting cable see page BDE 163.

HF-Anschlusskabel siehe Blatt BDE 163.

ERAGON modular
modular instruments 5 mm

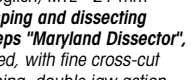
ERAGON modular
modulare Instrumente 5 mm

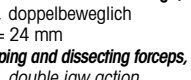
<p>ERAGON axial</p> <p>Alle Innenteile und Schaffrohre sind ebenfalls mit ERAGONaxial kombinierbar. <i>All jaw inserts and sheaths can also be combined with ERAGONaxial.</i></p>	Griffvarianten / Handle type				Drehradaufsatz, ERAGONaxial Knob attachment, ERAGONaxial
					
Typen / Types	83930082	83930083	83930084	83930085	8988

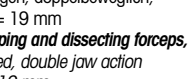
<p>Innenteil Jaw insert</p> 	Schaffrohr, isoliert Sheath tube, insulated		Griffvarianten / Handle type		<p>Komplett-Instrument</p> <ul style="list-style-type: none"> • Innenteil • Schaffrohr • Handgriff <p>Complete instrument</p> <ul style="list-style-type: none"> • Jaw insert • Sheath • Handle
	NL / WL 330 mm	NL / WL 450 mm			
Typen / Types	8393933	8394933	83930074		Typen / Types
 <p>Greif- und Dissektionszange "Maryland Dissektor", gebogen, mit feiner Verzahnung, doppelbeweglich, MTL= 21 mm <i>Grasping and dissecting forceps "Maryland Dissector", curved, with fine cross-cut toothing, double jaw action JL= 21 mm</i></p>	8393.281	●		●	83932817
 <p>Greif- und Dissektionszange "Maryland Dissektor", gebogen, mit feiner Verzahnung, doppelbeweglich, MTL= 21 mm <i>Grasping and dissecting forceps "Maryland Dissector", curved, with fine cross-cut toothing, double jaw action JL= 21 mm</i></p>	8394.281		●	●	83942817
 <p>Greif- und Dissektionszange, lang, doppelbeweglich MTL= 24 mm <i>Grasping and dissecting forceps, long, double jaw action JL= 24 mm</i></p>	8393194	●		●	83931947
 <p>Greif- und Dissektionszange, lang, doppelbeweglich MTL= 24 mm <i>Grasping and dissecting forceps, long, double jaw action JL= 24 mm</i></p>	8394194		●	●	83941947
 <p>Greif- und Dissektionszange, gebogen, doppelbeweglich, MTL= 19 mm <i>Grasping and dissecting forceps, curved, double jaw action JL= 19 mm</i></p>	8393240	●		●	83932407
 <p>Greif- und Dissektionszange, gebogen, doppelbeweglich, MTL= 19 mm <i>Grasping and dissecting forceps, curved, double jaw action JL= 19 mm</i></p>	8394240		●	●	83942407

* JL = Jaw length when jaws closed (approximate measurements)





* MTL = Maulteillänge bei geschlossenem Maulteil (gerundete Angaben)









HF connecting cable see page BDE 163.

HF-Anschlusskabel siehe Blatt BDE 163.

ERAGON modular
modular instruments 5 mm

ERAGON modular
modulare Instrumente 5 mm

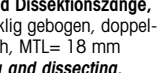
<p>ERAGON axial</p> <p>Alle Innenteile und Schaftrohre sind ebenfalls mit ERAGONaxial kombinierbar. <i>All jaw inserts and sheaths can also be combined with ERAGONaxial.</i></p>	Griffvarianten / Handle type				<p>Drehradaufsatz, ERAGONaxial Knob attachment, ERAGONaxial</p>  <p>autoklavierbar / autoclavable</p>
					
Typen / Types	83930082	83930083	83930084	83930085	8988

<p>Innenteil Jaw insert</p>  <p>MTL / JL*</p>	Schaftrohr, isoliert Sheath tube, insulated		Griffvarianten / Handle type		<p>Komplett-Instrument</p> <ul style="list-style-type: none"> • Innenteil • Schaftrohr • Handgriff <p>Complete instrument</p> <ul style="list-style-type: none"> • Jaw insert • Sheath • Handle
					
Typen / Types	NL / WL 330 mm	NL / WL 450 mm	mit Sperre, drehbar with locking mechanism, rotatable		Typen / Types
 <p>Greif- und Dissektionszange "Mixer", abgewinkelt, feine pyramidenförmige Verzahnung, doppelbeweglich, MTL= 22 mm <i>Grasping and dissecting forceps "Mixer", angled, fine pyramidal-shaped teeth, double jaw action, JL= 22 mm</i></p>	8393.283	●		●	83932837
 <p>Greif- und Dissektionszange, rechtwinklig gebogen, doppelbeweglich, MTL= 18 mm <i>Grasping and dissecting forceps, right-angled, double jaw action, JL= 18 mm</i></p>	8393192	●		●	83931927
 <p>Greif- und Dissektionszange, kurz, feine Spitze, doppelbeweglich, MTL= 19 mm <i>Grasping and dissecting forceps, short, fine tip, double jaw action, JL= 19 mm</i></p>	8394192		●	●	83941927
 <p>Greif- und Dissektionszange, kurz, feine Spitze, doppelbeweglich, MTL= 19 mm <i>Grasping and dissecting forceps, short, fine tip, double jaw action, JL= 19 mm</i></p>	8393200	●		●	83932007
	8394200		●	●	83942007

* JL = Jaw length when jaws closed (approximate measurements)





* MTL = Maulteillänge bei geschlossenem Maulteil (gerundete Angaben)







HF connecting cable see page BDE 163.

HF-Anschlusskabel siehe Blatt BDE 163.

ERAGON modular
modular instruments 5 mm

ERAGON modular
modulare Instrumente 5 mm

<p>ERAGONaxial</p> <p>Alle Innenteile und Schaffrohre sind ebenfalls mit ERAGONaxial kombinierbar. <i>All jaw inserts and sheaths can also be combined with ERAGONaxial.</i></p>	Griffvarianten / Handle type				Drehradaufsatz, ERAGONaxial Knob attachment, ERAGONaxial
					
Typen / Types	83930082	83930083	83930084	83930085	8988





<p>Innenteil Jaw insert</p> 	Schaffrohr, isoliert Sheath tube, insulated		Griffvarianten / Handle type		<p>Komplett-Instrument</p> <ul style="list-style-type: none"> • Innenteil • Schaffrohr • Handgriff <p>Complete instrument</p> <ul style="list-style-type: none"> • Jaw insert • Sheath • Handle 	
		NL / WL 330 mm	NL / WL 450 mm			mit Sperre, drehbar with locking mechanism, rotatable
Typen / Types	8393933	8394933	83930074		Typen / Types	
	8393197	●			●	83931977
<p>Greif- und Dissektionszange, lang, doppelbeweglich, MTL= 30 mm Grasping and dissecting, long, double jaw action JL= 30 mm</p>	8394197		●		●	83941977
	8393198	●			●	83931987
<p>Greifzange, gebogen, feine Spitze, doppelbeweglich, MTL= 33 mm Grasping forceps, curved, fine tip, double jaw action, JL= 33 mm</p>	8394198		●		●	83941987
	8393199	●			●	83931997
<p>Greif- und Dissektionszange lang, feine Spitze, doppelbeweglich, MTL= 32 mm Grasping and dissecting forceps long, fine tip, double jaw action, JL= 32 mm</p>	8394199		●		●	83941997







* JL = Jaw length when jaws closed (approximate measurements)

* MTL = Maulteillänge bei geschlossenem Maulteil (gerundete Angaben)

ERAGON modular
modular instruments 5 mm

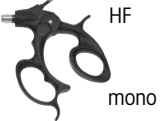
ERAGON modular
modulare Instrumente 5 mm

<p>ERAGON axial</p> <p>Alle Innenteile und Schaffrohre sind ebenfalls mit ERAGONaxial kombinierbar. <i>All jaw inserts and sheaths can also be combined with ERAGONaxial.</i></p>	Griffvarianten / Handle type				<p>Drehradaufsatz, ERAGONaxial Knob attachment, ERAGONaxial</p>  <p>autoklavierbar / autoclavable</p>
	 <p>mit Sperre, drehbar with locking mechanism, rotatable</p>	 <p>HF / mono ohne Sperre, drehbar without locking mechanism, rotatable</p>	 <p>HF / mono mit Sperre, drehbar with locking mechanism, rotatable</p>	 <p>mit Sperre, nicht drehbar with locking mechanism, not rotatable</p>	
Typen / Types	83930082	83930083	83930084	83930085	8988

<p>Innenteil Jaw insert</p>  <p>MTL / JL*</p>	<p>Schaffrohr, isoliert Sheath tube, insulated</p>  <p>NL / WL 330 mm</p>	Griffvarianten / Handle type		<p>Komplett-Instrument</p> <ul style="list-style-type: none"> • Innenteil • Schaffrohr • Handgriff <p>Complete instrument</p> <ul style="list-style-type: none"> • Jaw insert • Sheath • Handle
		 <p>HF mono ohne Sperre, drehbar without locking mechanism, rotatable</p>	 <p>HF mono mit Sperre, drehbar with locking mechanism, rotatable</p>	
Typen / Types	8393933	83930073	83930074	Typen / Types
 <p>Greif- und Dissektionszange, feine pyramidenförmige Verzahnung, schlank, doppel- beweglich, MTL= 23 mm Grasping and dissecting forceps, fine pyramid-shaped toothing, slimline, double jaw action, JL= 23 mm</p>	8393.289	●	●	83932897
 <p>Dissektionszange "Petelin", 30° links abgewinkelt, mit Querverzahnung, einseitig beweglich, MTL= 17 mm Dissecting forceps "Petelin", angled 30° left, with horizon- tal serration, single jaw action, JL= 17 mm</p>	8393.282	●	●	83932827
 <p>Greif- und Dissektionszange "Dolphin", abgewinkelt, feine Querverzahnung, mit Maulkehle, schlank, MTL= 17 mm Grasping and dissecting forceps, "Dolphin", angled, fine cross-cut toothing, with jaw throat, slimline, double jaw action, JL= 17 mm</p>	8393.285	●	●	83932857

* JL = Jaw length when jaws closed (approximate measurements)





* MTL = Maulteillänge bei geschlossenem Maulteil (gerundete Angaben)









HF connecting cable see page BDE 163.

HF-Anschlusskabel siehe Blatt BDE 163.

ERAGON modular
modular instruments 5 mm

ERAGON modular
modulare Instrumente 5 mm

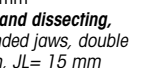
<p>ERAGONaxial</p> <p>Alle Innenteile und Schaftröhre sind ebenfalls mit ERAGONaxial kombinierbar. All jaw inserts and sheaths can also be combined with ERAGONaxial.</p>	Griffvarianten / Handle type				<p>Drehradaufsatz, ERAGONaxial Knob attachment, ERAGONaxial</p>  <p>autoklavierbar / autoclavable</p>
	 <p>mit Sperre, drehbar with locking mechanism, rotatable</p>	 <p>HF / mono ohne Sperre, drehbar without locking mechanism, rotatable</p>	 <p>HF / mono mit Sperre, drehbar with locking mechanism, rotatable</p>	 <p>mit Sperre, nicht drehbar with locking mechanism, not rotatable</p>	
Typen / Types	83930082	83930083	83930084	83930085	8988

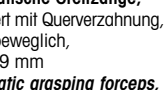
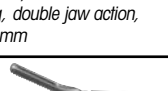
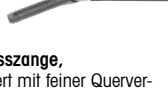
<p>Innenteil Jaw insert</p>  <p>MTL / JL*</p>	Schaftröhr, isoliert Sheath tube, insulated			Griffvarianten / Handle type		<p>Komplett-Instrument</p> <ul style="list-style-type: none"> • Innenteil • Schaftröhr • Handgriff <p>Complete instrument</p> <ul style="list-style-type: none"> • Jaw insert • Sheath • Handle
	 <p>NL / WL 260 mm</p>	 <p>NL / WL 330 mm</p>	 <p>NL / WL 450 mm</p>	 <p>mit Sperre, drehbar with locking mechanism, rotatable</p>	 <p>HF mono mit Sperre, drehbar with locking mechanism, rotatable</p>	
 <p>8393230</p> <p>Greif- und Dissektionszange, kurzes abgerundetes Maulteil, doppelbeweglich, MTL= 15 mm Grasping and dissecting, short rounded jaws, double jaw action, JL= 15 mm</p>						83932307
 <p>8394230</p> <p>Greif- und Dissektionszange, kurzes abgerundetes Maulteil, doppelbeweglich, MTL= 15 mm Grasping and dissecting, short rounded jaws, double jaw action, JL= 15 mm</p>						83942307
 <p>8392.181</p> <p>Atraumatische Greifzange, gefenestert mit Querverzahnung, doppelbeweglich, MTL= 19 mm Atraumatic grasping forceps, fenestrated, with cross-cut toothing, double jaw action, JL= 19 mm</p>						83921817
 <p>8393.181</p> <p>Atraumatische Greifzange, gefenestert mit Querverzahnung, doppelbeweglich, MTL= 19 mm Atraumatic grasping forceps, fenestrated, with cross-cut toothing, double jaw action, JL= 19 mm</p>						83931817
 <p>8394.181</p> <p>Atraumatische Greifzange, gefenestert mit Querverzahnung, doppelbeweglich, MTL= 19 mm Atraumatic grasping forceps, fenestrated, with cross-cut toothing, double jaw action, JL= 19 mm</p>						83941817
 <p>8393.182</p> <p>Tellerfazzange, gefenestert mit feiner Querverzahnung, doppelbeweglich, MTL= 18 mm Plate-shaped grasping forceps, fenestrated with fine cross-cut toothing, double jaw action, JL= 18 mm</p>						83931827

* JL = Jaw length when jaws closed (approximate measurements)





* MTL = Maulteillänge bei geschlossenem Maulteil (gerundete Angaben)







HF connecting cable see page BDE 163.

HF-Anschlusskabel siehe Blatt BDE 163.

ERAGON modular
modular instruments 5 mm

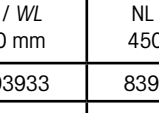
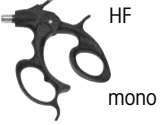
ERAGON modular
modulare Instrumente 5 mm

<p>ERAGON axial</p> <p>Alle Innenteile und Schaftrohre sind ebenfalls mit ERAGONaxial kombinierbar. <i>All jaw inserts and sheaths can also be combined with ERAGONaxial.</i></p>	Griffvarianten / Handle type				<p>Drehradaufsatz, ERAGONaxial Knob attachment, ERAGONaxial</p>  <p>autoklavierbar / autoclavable</p>
	 <p>mit Sperre, drehbar with locking mechanism, rotatable</p>	 <p>HF / mono ohne Sperre, drehbar without locking mechanism, rotatable</p>	 <p>HF / mono mit Sperre, drehbar with locking mechanism, rotatable</p>	 <p>mit Sperre, nicht drehbar with locking mechanism, not rotatable</p>	
Typen / Types	83930082	83930083	83930084	83930085	

<p>Innenteil Jaw insert</p>  <p>MTL / JL*</p>	Schaftrohr, isoliert Sheath tube, insulated		Griffvarianten / Handle type		<p>Komplett-Instrument</p> <ul style="list-style-type: none"> • Innenteil • Schaftrohr • Handgriff <p>Complete instrument</p> <ul style="list-style-type: none"> • Jaw insert • Sheath • Handle
	 <p>NL / WL 330 mm</p>	 <p>NL / WL 450 mm</p>	 <p>HF mono ohne Sperre, drehbar without locking mechanism, rotatable</p>	 <p>HF mono mit Sperre, drehbar with locking mechanism, rotatable</p>	
Typen / Types	8393933	8394933	83930073	83930074	
 <p>Greif- und Präparierzange, feine Querverzahnung, doppelbeweglich, MTL= 21 mm Grasping and dissecting forceps, fine cross-cut toothing, double jaw action, JL= 21 mm</p>	8393.183	●		●	83931837
 <p>Greif- und Dissektionszange, gefenstert mit feiner Querverzahnung, einseitig beweglich MTL= 21 mm Grasping and dissecting forceps, perforated, fine horizontal serrations, single jaw action, JL= 21 mm</p>	8393.185	●		●	83931857
 <p>Greif- und Dissektionszange, gefenstert mit feiner Querverzahnung, einseitig beweglich, MTL= 26 mm Grasping and dissecting forceps, perforated, fine horizontal serrations, single jaw action, JL= 26 mm</p>	8393.184	●		●	83931847
	8394.184		●	●	83941847

* JL = Jaw length when jaws closed (approximate measurements)





* MTL = Maulteillänge bei geschlossenem Maulteil (gerundete Angaben)







HF connecting cable see page BDE 163.

HF-Anschlusskabel siehe Blatt BDE 163.

ERAGON modular
modular instruments 5 mm

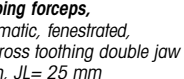
ERAGON modular
modulare Instrumente 5 mm

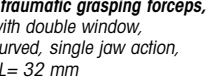
ERAGON axial Alle Innenteile und Schaffrohre sind ebenfalls mit ERAGONaxial kombinierbar. <i>All jaw inserts and sheaths can also be combined with ERAGONaxial.</i>	Griffvarianten / Handle type				Drehradaufsatz, ERAGONaxial Knob attachment, ERAGONaxial
		 mit Sperre, drehbar with locking mechanism, rotatable	 HF / mono ohne Sperre, drehbar without locking mechanism, rotatable	 HF / mono mit Sperre, drehbar with locking mechanism, rotatable	 mit Sperre, nicht drehbar with locking mechanism, not rotatable
Typen / Types	83930082	83930083	83930084	83930085	8988

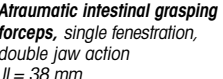
Innenteil <i>Jaw insert</i>	Schaffrohr, isoliert <i>Sheath tube, insulated</i>		Griffvarianten / Handle type		Komplett-Instrument • Innenteil • Schaffrohr • Handgriff Complete instrument • Jaw insert • Sheath • Handle
	 MTL / JL*	NL / WL 330 mm	NL / WL 450 mm	 mit Sperre, drehbar with locking mechanism, rotatable	
Typen / Types	8393933	8394933	83930072		
 Greifzange, atraumatisch, gefenestert, feine Querverzahnung, doppelbe- weglich, MTL= 25 mm Grasping forceps, atraumatic, fenestrated, fine cross toothing double jaw action, JL= 25 mm	8393250	●		●	83932507
 Greifzange, atraumatisch, gefenestert, feine Querverzahnung, doppelbe- weglich, MTL= 25 mm Grasping forceps, atraumatic, fenestrated, fine cross toothing double jaw action, JL= 25 mm	8394250		●	●	83942507
 Atraumatische Greifzange, doppelt gefenestert, gebogen, einfach beweglich- MTL= 32 mm Atraumatic grasping forceps, with double window, curved, single jaw action, JL= 32 mm	8393229	●		●	83932297
 Atraumatische Greifzange, doppelt gefenestert, gebogen, einfach beweglich- MTL= 32 mm Atraumatic grasping forceps, with double window, curved, single jaw action, JL= 32 mm	8394229		●	●	83942297
 Atraumatische Darmfasszange, einfach gefenestert, doppeltbeweglich, MTL= 38 mm Atraumatic intestinal grasping forceps, single fenestration, double jaw action JL= 38 mm	8393249	●		●	83932497
 Atraumatische Darmfasszange, einfach gefenestert, doppeltbeweglich, MTL= 38 mm Atraumatic intestinal grasping forceps, single fenestration, double jaw action JL= 38 mm	8394249		●	●	83942497

* JL = Jaw length when jaws closed (approximate measurements)

* MTL = Maulteillänge bei geschlossenem Maulteil (gerundete Angaben)

HF connecting cable see page BDE 163.





HF-Anschlusskabel siehe Blatt BDE 163.







ERAGON modular

modular instruments 5 mm

ERAGON modular

modulare Instrumente 5 mm

<p>ERAGON axial</p> <p>Alle Innenteile und Schaftröhre sind ebenfalls mit ERAGONaxial kombinierbar. All jaw inserts and sheaths can also be combined with ERAGONaxial.</p>	Griffvarianten / Handle type				<p>Drehradaufsatz, ERAGONaxial Knob attachment, ERAGONaxial</p>  <p>autoklavierbar / autoclavable</p>
	 <p>mit Sperre, drehbar with locking mechanism, rotatable</p>	 <p>HF / mono ohne Sperre, drehbar without locking mechanism, rotatable</p>	 <p>HF / mono mit Sperre, drehbar with locking mechanism, rotatable</p>	 <p>mit Sperre, nicht drehbar with locking mechanism, not rotatable</p>	
Typen / Types	83930082	83930083	83930084	83930085	8988

<p>Innenteil Jaw insert</p>  <p>MTL / JL*</p>	Schaftröhre, isoliert Sheath tube, insulated		Griffvarianten / Handle type		<p>Komplett-Instrument</p> <ul style="list-style-type: none"> • Innenteil • Schaftröhre • Handgriff <p>Complete instrument</p> <ul style="list-style-type: none"> • Jaw insert • Sheath • Handle 	
	NL / WL 330 mm	NL / WL 450 mm	 <p>mit Sperre, drehbar with locking mechanism, rotatable</p>	 <p>HF mono mit Sperre, drehbar with locking mechanism, rotatable</p>		Typen / Types
Typen / Types	8393933	8394933	83930072	83930074	Typen / Types	
 <p>Greifzange "Debaquey", gebogen, doppelbeweglich MTL= 35 mm Grasping forceps "Debaquey", curved, double jaw action, JL= 35 mm</p>	8393256	●			●	83932567
 <p>Greifzange "Debaquey", doppelbeweglich, MTL= 47 mm Grasping forceps "Debaquey", double jaw action, JL= 47 mm</p>	8393258	●			●	83932587
	8394258		●		●	83942587
 <p>Greif- und Präparierzange, feine Querverzahnung, gefensterter, doppelbeweglich, mit federnden Maulteilen, MTL= 47 mm Grasping and dissecting forceps, fine cross-cut toothing, fenestrated, double jaw action, with spring jaws, JL= 47 mm</p>	8393.189	●			●	83931897
	8394.189		●		●	83941897

* JL = Jaw length when jaws closed (approximate measurements)





* MTL = Maulteillänge bei geschlossenem Maulteil (gerundete Angaben)



HF connecting cable see page BDE 163.

HF-Anschlusskabel siehe Blatt BDE 163.

ERAGON modular
modular instruments 5 mm

ERAGON modular
modulare Instrumente 5 mm

<p>ERAGON axial</p> <p>Alle Innenteile und Schaffrohre sind ebenfalls mit ERAGONaxial kombinierbar. <i>All jaw inserts and sheaths can also be combined with ERAGONaxial.</i></p>	Griffvarianten / Handle type				<p>Drehradaufsatz, ERAGONaxial Knob attachment, ERAGONaxial</p>  <p>autoklavierbar / autoclavable</p>
	 <p>mit Sperre, drehbar with locking mechanism, rotatable</p>	 <p>HF / mono ohne Sperre, drehbar without locking mechanism, rotatable</p>	 <p>HF / mono mit Sperre, drehbar with locking mechanism, rotatable</p>	 <p>mit Sperre, nicht drehbar with locking mechanism, not rotatable</p>	
	83930082	83930083	83930084	83930085	8988





<p>Innenteil <i>Jaw insert</i></p>  <p>MTL / JL*</p>	<p>Schaffrohr, isoliert <i>Sheath tube, insulated</i></p>  <p>NL / WL 330 mm</p>	Griffvarianten / Handle type		<p>Komplett-Instrument</p> <ul style="list-style-type: none"> • Innenteil • Schaffrohr • Handgriff <p>Complete instrument</p> <ul style="list-style-type: none"> • Jaw insert • Sheath • Handle
		 <p>mit Sperre, drehbar with locking mechanism, rotatable</p>	<p>Typen / Types</p>	
<p>8393.291</p> <p>Greif- und Dissektionszange, atraumatische Klemme "Debakey", Längsillen mit feiner Querverzahnung, doppelbeweglich, mit federnden Maulteilen, MTL= 47 mm <i>Grasping and dissecting forceps, atraumatic clip "Debakey", longitudinal grooves with fine cross-cut toothing, double jaw action, with spring jaws, JL= 47 mm</i></p>	●	●	83932917	
<p>8393190</p> <p>Greif- und Dissektionszange "Debakey", atraumatische Klemme, doppelbeweglich, MTL= 39 mm <i>Grasping and dissecting forceps "Debakey", atraumatic clip, double jaw action, JL= 39 mm</i></p>	●	●	83931907	
<p>8393191</p> <p>Greif- und Dissektionszange "Debakey", atraumatische Klemme, doppelbeweglich, MTL= 48 mm <i>Grasping and dissecting forceps "Debakey", atraumatic clip, double jaw action, JL= 48 mm</i></p>	●	●	83931917	





* JL = Jaw length when jaws closed (approximate measurements)

* MTL = Maulteillänge bei geschlossenem Maulteil (gerundete Angaben)

ERAGON modular
modular instruments 5 mm

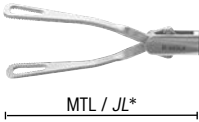
ERAGON modular
modulare Instrumente 5 mm

<p>ERAGON axial</p> <p>Alle Innenteile und Schaftrohre sind ebenfalls mit ERAGONaxial kombinierbar. <i>All jaw inserts and sheaths can also be combined with ERAGONaxial.</i></p>	Griffvarianten / Handle type				<p>Drehradaufsatz, ERAGONaxial Knob attachment, ERAGONaxial</p>  <p>autoklavierbar / autoclavable</p>
	 <p>mit Sperre, drehbar with locking mechanism, rotatable</p>	 <p>HF / mono ohne Sperre, drehbar without locking mechanism, rotatable</p>	 <p>HF / mono mit Sperre, drehbar with locking mechanism, rotatable</p>	 <p>mit Sperre, nicht drehbar with locking mechanism, not rotatable</p>	
Typen / Types	83930082	83930083	83930084	83930085	

<p>Innenteil Jaw insert</p>  <p>MTL / JL*</p>	Schaftrohr, isoliert Sheath tube, insulated		Griffvarianten / Handle type		<p>Komplett-Instrument</p> <ul style="list-style-type: none"> • Innenteil • Schaftrohr • Handgriff <p>Complete instrument</p> <ul style="list-style-type: none"> • Jaw insert • Sheath • Handle
	NL / WL 330 mm	NL / WL 450 mm	mit Sperre, drehbar with locking mechanism, rotatable		
Typen / Types	8393933	8394933	83930072		
 <p>Greif- und Extraktionszange, dreiecksförmig, gefensternt, mit feiner Querverzahnung, doppelbeweglich, mit federnden Maulteilen, MTL= 37 mm <i>Grasping and extraction forceps, triangular, fenestrated, with finecross-cut toothing, double jaw action, with spring jaws, JL= 37 mm</i></p>	8393.188	●		●	83931887
 <p>Greifzange "Babcock", Greiffläche mit feiner Querverzahnung, doppelbeweglich, MTL= 24 mm <i>Grasping forceps "Babcock", grasping surface with fine cross-cut toothing, double jaw action, JL= 24 mm</i></p>	8393.186	●		●	83931867
 <p>Greifzange "Babcock", große distale Greiffläche mit feiner Querverzahnung, doppelbeweglich, MTL= 26 mm <i>Grasping forceps "Babcock", grasping surface with fine cross-cut toothing, double jaw action, JL= 26 mm</i></p>	8393.187	●		●	83931877
	8394.187		●	●	83941877

* JL = Jaw length when jaws closed (approximate measurements)





* MTL = Maulteillänge bei geschlossenem Maulteil (gerundete Angaben)









HF connecting cable see page BDE 163.

HF-Anschlusskabel siehe Blatt BDE 163.

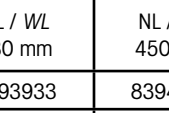
ERAGON modular
modular instruments 5 mm

ERAGON modular
modulare Instrumente 5 mm

<p>ERAGONaxial</p> <p>Alle Innenteile und Schaffrohre sind ebenfalls mit ERAGONaxial kombinierbar. All jaw inserts and sheaths can also be combined with ERAGONaxial.</p>	Griffvarianten / Handle type				<p>Drehradaufsatz, ERAGONaxial Knob attachment, ERAGONaxial</p>  <p>autoklavierbar / autoclavable</p>
	 mit Sperre, drehbar with locking mechanism, rotatable	 HF / mono ohne Sperre, drehbar without locking mechanism, rotatable	 HF / mono mit Sperre, drehbar with locking mechanism, rotatable	 mit Sperre, nicht drehbar with locking mechanism, not rotatable	

<p>Innenteil Jaw insert</p>  <p>MTL / JL*</p>	Schaffrohr, isoliert Sheath tube, insulated		Griffvarianten / Handle type			<p>Komplett-Instrument</p> <ul style="list-style-type: none"> • Innenteil • Schaffrohr • Handgriff <p>Complete instrument</p> <ul style="list-style-type: none"> • Jaw insert • Sheath • Handle 	
	 NL / WL 330 mm	 NL / WL 450 mm	 mit Sperre, drehbar with locking mechanism, rotatable	 ohne Sperre, drehbar without locking mechanism, rotatable	 mit Sperre, drehbar with locking mechanism, rotatable		<p>Typen / Types</p>
 <p>Greifzange "Babcock", gefensternt, einfach beweglich, MTL= 17 mm Grasping forceps "Babcock", fenestrated, single jaw action JL= 17 mm</p>	8393242	●		●			83932427
	8394242		●	●			83942427
 <p>Universal-Greifzange, pyramidenförmige Verzahnung und Querverzahnung, doppelbeweglich, MTL= 18 mm Universal grasping forceps, pyramid-shaped toothing and cross-cut toothing, double jaw action, JL= 18 mm</p>	8393.481	●				●	83934817
 <p>Universal-Greifzange, pyramidenförmige Verzahnung und Querverzahnung, doppelbeweglich, MTL= 26 mm Universal holding forceps, Pyramid-shaped toothing and cross-cut toothing, double jaw action JL= 26 mm</p>	8394.482		●		●		83944827

* JL = Jaw length when jaws closed (approximate measurements)





* MTL = Maulteillänge bei geschlossenem Maulteil (gerundete Angaben)





ERAGON modular

modular instruments 5 mm

ERAGON modular

modulare Instrumente 5 mm

<p>ERAGON axial</p> <p>Alle Innenteile und Schaftrohre sind ebenfalls mit ERAGONaxial kombinierbar. <i>All jaw inserts and sheaths can also be combined with ERAGONaxial.</i></p>	Griffvarianten / Handle type				<p>Drehradaufsatz, ERAGONaxial Knob attachment, ERAGONaxial</p>  <p>autoklavierbar / autoclavable</p>
	 <p>mit Sperre, drehbar with locking mechanism, rotatable</p>	 <p>HF / mono ohne Sperre, drehbar without locking mechanism, rotatable</p>	 <p>HF / mono mit Sperre, drehbar with locking mechanism, rotatable</p>	 <p>mit Sperre, nicht drehbar with locking mechanism, not rotatable</p>	
Typen / Types	83930082	83930083	83930084	83930085	

<p>Innenteil Jaw insert</p>  <p>MTL / JL*</p>	Schaftrohr, isoliert Sheath tube, insulated		Griffvarianten / Handle type		<p>Komplett-Instrument</p> <ul style="list-style-type: none"> • Innenteil • Schaftrohr • Handgriff <p>Complete instrument</p> <ul style="list-style-type: none"> • Jaw insert • Sheath • Handle
	NL / WL 330 mm	NL / WL 450 mm	mit Sperre, drehbar with locking mechanism, rotatable		
Typen / Types	8393933	8394933	83930072		
 <p>Greifzange, atraumatisch, feine Querverzahnung, doppelbeweglich, MTL= 29 mm Grasping forceps, atraumatic, fine cross toothing, double jaw action, JL= 29 mm</p>	8393223	●		●	83932237
	8394223		●	●	83942237
 <p>Atraumatische Greifzange, Maulkehle mit gewelltem Zahnrand, einfach beweglich, MTL= 26 mm Atraumatic grasping forceps, jaw throat with wavy tooth edge, single jaw action, JL= 26 mm</p>	8393.292	●		●	83932925
	8394.292		●	●	83942925
 <p>Atraumatische Greifzange, Maulkehle mit gewelltem Zahnrand, doppelbeweglich, MTL= 26 mm Atraumatic grasping forceps, jaw throat with wavy tooth edge, double jaw action, JL= 26 mm</p>	8393.293	●		●	83932935
	8394.293		●	●	83942935

* JL = Jaw length when jaws closed (approximate measurements)





* MTL = Maulteillänge bei geschlossenem Maulteil (gerundete Angaben)







HF connecting cable see page BDE 163.

HF-Anschlusskabel siehe Blatt BDE 163.

ERAGON modular
modular instruments 5 mm

ERAGON modular
modulare Instrumente 5 mm

<p>ERAGONaxial</p> <p>Alle Innenteile und Schaffrohre sind ebenfalls mit ERAGONaxial kombinierbar. <i>All jaw inserts and sheaths can also be combined with ERAGONaxial.</i></p>	Griffvarianten / Handle type				<p>Drehradaufsatz, ERAGONaxial Knob attachment, ERAGONaxial</p>  <p>autoklavierbar / autoclavable</p>
	 <p>mit Sperre, drehbar with locking mechanism, rotatable</p>	 <p>HF / mono ohne Sperre, drehbar without locking mechanism, rotatable</p>	 <p>HF / mono mit Sperre, drehbar with locking mechanism, rotatable</p>	 <p>mit Sperre, nicht drehbar with locking mechanism, not rotatable</p>	

<p>Innenteil Jaw insert</p>  <p>MTL / JL*</p>	<p>Schaffrohr, isoliert Sheath tube, insulated</p>  <p>NL / WL 330 mm</p>	Griffvarianten / Handle type		<p>Komplett-Instrument</p> <ul style="list-style-type: none"> • Innenteil • Schaffrohr • Handgriff <p>Complete instrument</p> <ul style="list-style-type: none"> • Jaw insert • Sheath • Handle
		<p>HF / mono</p> 	<p>mit Sperre, drehbar with locking mechanism, rotatable</p>	
 <p>Greif- und Dissektionszange, feine pyramidenförmige Verzahnung, schlank, doppelbeweglich, MTL= 19 mm Grasping and dissecting forceps, fine pyramid-shaped toothing, slimline, double jaw action, JL= 19 mm</p>	8393.288	●	●	83932887
 <p>Greifzange, mit Zahnreihe, doppelbeweg- lich, MTL= 17 mm Grasping forceps with row of teeth, double jaw action, JL= 17 mm</p>	8393.485	●	●	83934857
 <p>Greif- und Präparierzange, atraumatisch, feine Querver- zahnung, doppelbeweglich, MTL= 16 mm Grasping and dissecting forceps, atraumatic, fine cross toothing, double jaw action, JL= 16 mm</p>	8393210	●	●	83932107

* JL = Jaw length when jaws closed (approximate measurements)





* MTL = Maulteillänge bei geschlossenem Maulteil (gerundete Angaben)









ERAGON modular

modular instruments 5 mm

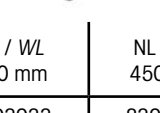
ERAGON modular

modulare Instrumente 5 mm

<p>ERAGON axial</p> <p>Alle Innenteile und Schaftrohre sind ebenfalls mit ERAGONaxial kombinierbar. All jaw inserts and sheaths can also be combined with ERAGONaxial.</p>	Griffvarianten / Handle type				<p>Drehradaufsatz, ERAGONaxial Knob attachment, ERAGONaxial</p>  <p>autoklavierbar / autoclavable</p>
	 <p>mit Sperre, drehbar with locking mechanism, rotatable</p>	 <p>ohne Sperre, drehbar without locking mechanism, rotatable</p>	 <p>mit Sperre, drehbar with locking mechanism, rotatable</p>	 <p>mit Sperre, nicht drehbar with locking mechanism, not rotatable</p>	
Typen / Types	83930082	83930083	83930084	83930085	8988

<p>Innenteil Jaw insert</p>  <p>MTL / JL*</p>	Schaftrohr, isoliert Sheath tube, insulated		Griffvarianten / Handle type			<p>Komplett-Instrument</p> <ul style="list-style-type: none"> • Innenteil • Schaftrohr • Handgriff <p>Complete instrument</p> <ul style="list-style-type: none"> • Jaw insert • Sheath • Handle
	 <p>NL / WL 330 mm</p>	 <p>NL / WL 450 mm</p>	 <p>mit Sperre, drehbar with locking mechanism, rotatable</p>	 <p>ohne Sperre, drehbar without locking mechanism, rotatable</p>	 <p>mit Sperre, drehbar with locking mechanism, rotatable</p>	
Typen / Types	8393933	8394933	83930072	83930073	83930074	Typen / Types
 <p>Greif- und Dissektionszange, doppelbeweglich, MTL= 16 mm Grasping and dissecting forceps, double jaw action, JL= 16 mm</p>	8393193	●	●	●	●	83931937
	8394193	●	●	●	●	83941937
 <p>Greif- und Präparierzange, atraumatisch, doppelbeweglich, MTL= 19 mm Grasping and dissecting forceps, atraumatic, double jaw action, JL= 19 mm</p>	8393220	●	●	●	●	83932207
	8394220	●	●	●	●	83942207
 <p>Atraumatische Greifzange, glatt, doppelbeweglich, MTL= 18 mm Atraumatic grasping forceps, smooth, double jaw action, JL= 18 mm</p>	8393.195	●	●	●	●	83931957
	8394.195	●	●	●	●	83941957

* JL = Jaw length when jaws closed (approximate measurements)





* MTL = Maulteillänge bei geschlossenem Maulteil (gerundete Angaben)







HF connecting cable see page BDE 163.

HF-Anschlusskabel siehe Blatt BDE 163.

ERAGON modular
modular instruments 5 mm

ERAGON modular
modulare Instrumente 5 mm

<p>ERAGONaxial</p> <p>Alle Innenteile und Schaffrohre sind ebenfalls mit ERAGONaxial kombinierbar. <i>All jaw inserts and sheaths can also be combined with ERAGONaxial.</i></p>	Griffvarianten / Handle type				<p>Drehradaufsatz, ERAGONaxial Knob attachment, ERAGONaxial</p>  <p>autoklavierbar / autoclavable</p>
	 <p>mit Sperre, drehbar with locking mechanism, rotatable</p>	 <p>HF / mono ohne Sperre, drehbar without locking mechanism, rotatable</p>	 <p>HF / mono mit Sperre, drehbar with locking mechanism, rotatable</p>	 <p>mit Sperre, nicht drehbar with locking mechanism, not rotatable</p>	
	83930082	83930083	83930084	83930085	8988





<p>Innenteil Jaw insert</p>  <p>MTL / JL*</p>	<p>Schaffrohr, isoliert Sheath tube, insulated</p>  <p>NL / WL 330 mm</p>	Griffvarianten / Handle type		<p>Komplett-Instrument</p> <ul style="list-style-type: none"> • Innenteil • Schaffrohr • Handgriff <p>Complete instrument</p> <ul style="list-style-type: none"> • Jaw insert • Sheath • Handle
		<p>HF / mono</p> 	<p>mit Sperre, drehbar with locking mechanism, rotatable</p>	
Typen / Types	8393933	83930074		Typen / Types
 <p>Greifzange, mit einem Zahn, feine Querverzahnung, schlank, doppelbeweglich, MTL= 19 mm Grasping forceps, with one tooth, fine cross-cut toothing, slimline, double jaw action, JL= 19 mm</p>	8393.486	●	●	83934867
 <p>Greifzange, mit zwei Zähnen, feine Querverzahnung, einfach beweglich, MTL= 17 mm Grasping forceps, with two teeth, fine cross-cut toothing, single jaw action, JL= 17 mm</p>	8393.487	●	●	83934877
 <p>Greif- und Extraktionszange, "Hechtmaul" doppelbeweglich, MTL= 20 mm Grasping and extraction forceps, "pike-mouth" double jaw action, JL= 20 mm</p>	8393.483	●	●	83934837









* JL = Jaw length when jaws closed (approximate measurements)

* MTL = Maulteillänge bei geschlossenem Maulteil (gerundete Angaben)

ERAGON modular
modular instruments 5 mm

ERAGON modular
modulare Instrumente 5 mm

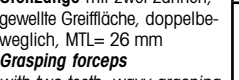
<p>ERAGON axial</p> <p>Alle Innenteile und Schaftrohre sind ebenfalls mit ERAGONaxial kombinierbar. <i>All jaw inserts and sheaths can also be combined with ERAGONaxial.</i></p>	Griffvarianten / Handle type				<p>Drehradaufsatz, ERAGONaxial Knob attachment, ERAGONaxial</p>  <p>autoklavierbar / autoclavable</p>
	 <p>mit Sperre, drehbar with locking mechanism, rotatable</p>	 <p>HF / mono ohne Sperre, drehbar without locking mechanism, rotatable</p>	 <p>HF / mono mit Sperre, drehbar with locking mechanism, rotatable</p>	 <p>mit Sperre, nicht drehbar with locking mechanism, not rotatable</p>	
Typen / Types	83930082	83930083	83930084	83930085	8988

<p>Innenteil Jaw insert</p>  <p>MTL / JL*</p>	Schaftrohr, isoliert Sheath tube, insulated		Griffvarianten / Handle type		<p>Komplett-Instrument</p> <ul style="list-style-type: none"> • Innenteil • Schaftrohr • Handgriff <p>Complete instrument</p> <ul style="list-style-type: none"> • Jaw insert • Sheath • Handle
	 <p>NL / WL 330 mm</p>	 <p>NL / WL 450 mm</p>	 <p>mit Sperre, drehbar with locking mechanism, rotatable</p>	 <p>HF mono mit Sperre, drehbar with locking mechanism, rotatable</p>	
Typen / Types	8393933	8394933	83930072	83930074	Typen / Types
 <p>Greif- und Extraktionszange, Myomfazzzange, 2/3-krallig, einfach beweglich, MTL= 29 mm <i>Grasping and extraction forceps, myoma grasping forceps, 2/3-claw, single jaw action, JL= 29 mm</i></p>	8393.488	●	●	●	83934887
 <p>Greifzange mit zwei Zähnen, gewellte Greiffläche, doppelbeweglich, MTL= 26 mm <i>Grasping forceps with two teeth, wavy grasping surface atraumatic, double jaw action, JL= 26 mm</i></p>	8393.490	●	●	●	83934907
 <p>Greifzange mit zwei Zähnen, gewellte Greiffläche, doppelbeweglich, MTL= 26 mm <i>Grasping forceps with two teeth, wavy grasping surface atraumatic, double jaw action, JL= 26 mm</i></p>	8394.490	●	●	●	83944907
 <p>Krallengreifzange, doppelbeweglich, MTL= 27 mm <i>Claw grasping forceps, double jaw action, JL= 27 mm</i></p>	8393.494	●	●	●	83934945

* JL = Jaw length when jaws closed (approximate measurements)





* MTL = Maulteillänge bei geschlossenem Maulteil (gerundete Angaben)





HF connecting cable see page BDE 163.

HF-Anschlusskabel siehe Blatt BDE 163.

ERAGON modular
modular instruments 5 mm

ERAGON modular
modulare Instrumente 5 mm

<p>ERAGON axial</p> <p>Alle Innenteile und Schaffrohre sind ebenfalls mit ERAGONaxial kombinierbar. All jaw inserts and sheaths can also be combined with ERAGONaxial.</p>	Griffvarianten / Handle type				<p>Drehradaufsatz, ERAGONaxial Knob attachment, ERAGONaxial</p>  <p>autoklavierbar / autoclavable</p>
	 <p>mit Sperre, drehbar with locking mechanism, rotatable</p>	 <p>HF / mono ohne Sperre, drehbar without locking mechanism, rotatable</p>	 <p>HF / mono mit Sperre, drehbar with locking mechanism, rotatable</p>	 <p>mit Sperre, nicht drehbar with locking mechanism, not rotatable</p>	
Typen / Types	83930082	83930083	83930084	83930085	





<p>Innenteil Jaw insert</p>  <p>MTL / JL*</p>	Schaffrohr, isoliert Sheath tube, insulated		Griffvarianten / Handle type		<p>Komplett-Instrument</p> <ul style="list-style-type: none"> • Innenteil • Schaffrohr • Handgriff <p>Complete instrument</p> <ul style="list-style-type: none"> • Jaw insert • Sheath • Handle
	NL / WL 330 mm	NL / WL 450 mm	HF / mono	ohne Sperre, drehbar without locking mechanism, rotatable	
Typen / Types	8393933	8394933	83930073		
 <p>Greif- und Koagulationszange, distale Querverzahnung mit Maulkehle, doppelbeweglich, MTL= 15 mm Grasping and coagulating forceps, distal cross-cut toothing with jaw throat, double jaw action, JL= 15 mm</p>	8393.287	●		●	83932877
 <p>Probe-Exzisionszange, mit Dornen, doppelbeweglich MTL= 13 mm Biopsy forceps, with pins, double jaw action JL= 13 mm</p>	8393.091	●		●	83930917
	8394.091		●	●	83940917
 <p>Probe-Exzisionszange, durchschneidend, einfach beweglich, MTL= 14 mm Biopsy forceps, severing, single jaw action JL= 14 mm</p>	8393.092	●		●	83930927
	8394.092		●	●	83940927



* JL = Jaw length when jaws closed (approximate measurements)

* MTL = Maulteillänge bei geschlossenem Maulteil (gerundete Angaben)

ERAGON modular
modular instruments 5 mm

ERAGON modular
modulare Instrumente 5 mm

<p>ERAGON axial</p> <p>Alle Innenteile und Schaftrohre sind ebenfalls mit ERAGONaxial kombinierbar. All jaw inserts and sheaths can also be combined with ERAGONaxial.</p>	Griffvarianten / Handle type				<p>Drehradaufsatz, ERAGONaxial Knob attachment, ERAGONaxial</p>  <p>autoklavierbar / autoclavable</p>
	 <p>mit Sperre, drehbar with locking mechanism, rotatable</p>	 <p>HF / mono ohne Sperre, drehbar without locking mechanism, rotatable</p>	 <p>HF / mono mit Sperre, drehbar with locking mechanism, rotatable</p>	 <p>mit Sperre, nicht drehbar with locking mechanism, not rotatable</p>	
Typen / Types	83930082	83930083	83930084	83930085	8988

<p>Innenteil Jaw insert</p>  <p>MTL / JL*</p>	<p>Schaftrohr, isoliert Sheath tube, insulated</p>  <p>NL / WL 330 mm</p>	Griffvarianten / Handle type		<p>Komplett-Instrument</p> <ul style="list-style-type: none"> • Innenteil • Schaftrohr • Handgriff <p>Complete instrument</p> <ul style="list-style-type: none"> • Jaw insert • Sheath • Handle
		<p>HF / mono</p> 		
Typen / Types	8393933	83930073		Typen / Types
<p>Probe-Exzisionszange, spitze Löffelzange, einfach beweglich, MTL= 20 mm Biopsy forceps, pointed spoon forceps, single jaw action, JL= 20 mm</p>	8393.093	●	●	83930937

* JL = Jaw length when jaws closed (approximate measurements)

* MTL = Maulteillänge bei geschlossenem Maulteil (gerundete Angaben)

Grasping Forceps 5 mm

Greifzangen 5 mm

with spring handle and cleaning channel

mit Federgriff und Spülanschluss

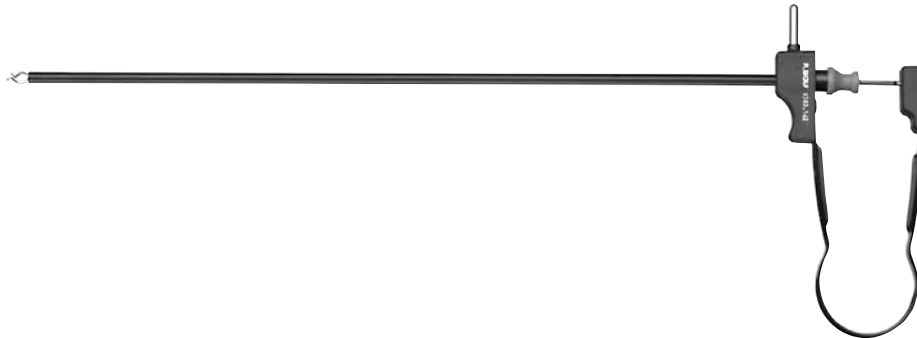

NL / WL
320 mm

Typen / Types



Greifzange monopolar, flach
Grasping forceps monopolar, flat

8383.141

HF connecting cable see page BDE 163.

HF-Anschlusskabel siehe Blatt BDE 163.

with spring handle and cleaning channel

mit Federgriff und Spülanschluss



NL / WL
310 mm

Type / Type





Greifzange mit gerieften Greifplättchen
Grasping forceps with grooved plates

8383.41

*Cholangiography Catheter
Grasping Forceps 5 mm*

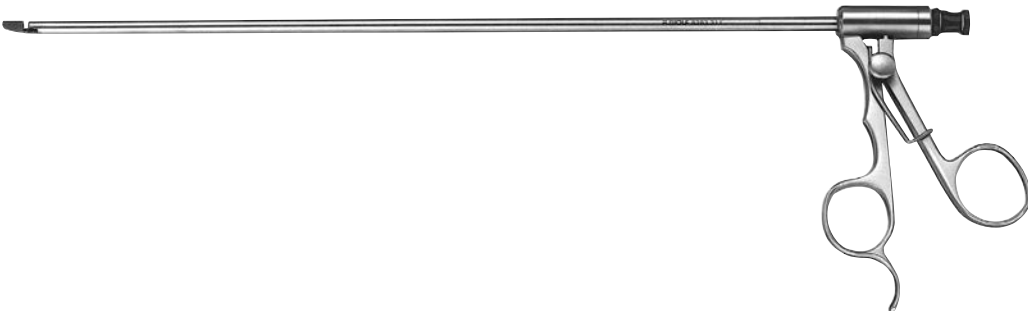
*Cholangiografie-Katheter-
Greifzange 5 mm*



		
	NL / WL 295 mm	Type / Type
 <p>Greifzange für Cholangiografie-Katheter Grasping forceps for cholangiography catheter</p>	●	8383.311







For introducing a cholangiography catheter to 7 Fr. into the cystic duct.

Zum Einbringen eines Cholangiografie-Katheters bis 7 Charr. in den Ductus cysticus.

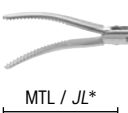
ERAGON modular
modular Instruments 10 mm

ERAGON modular
modulare Instrumente 10 mm

ERAGON axial	Griffvarianten / Handle type		Drehradaufsatz, ERAGONaxial Knob attachment, ERAGONaxial
	Alle Innenteile und Schaffrohre sind ebenfalls mit ERAGONaxial kombinierbar. <i>All jaw inserts and sheaths can also be combined with ERAGONaxial.</i>	 mit Sperre, drehbar <i>with locking mechanism, rotatable</i>	 mit Sperre, nicht drehbar <i>with locking mechanism, not rotatable</i>
Typen / Types	83930082	83930085	8988





Innenteil / Jaw insert	Schaffrohr, unisoliert Sheath tube, uninsulated		Griffvarianten / Handle type		Komplett-Instrument • Innenteil • Schaffrohr • Handgriff Complete instrument • Jaw insert • Sheath tube • Handle
	 MTL / JL*	NL / WL 330 mm	NL / WL 450 mm	 mit Sperre, ohne HF-Anschluss <i>with locking mechanism, without RF connector</i>	
	Typen / Types	8395902	8396902	83930072	Typen / Types
 Greif- / Dissektionszange "Maryland", doppelbeweglich MTL= 36 mm <i>Grasping and dissecting forceps, "Maryland", double jaw action, JL= 36mm</i>	8395.225	●		●	83952257
	8396225		●	●	83962257
 Dissektionszange, rechtwinkelig gebogen, doppelbeweglich, MTL= 35 mm <i>Dissecting forceps, right angled, both jaw action, JL= 35 mm</i>	8395.226	●		●	83952268
	8396226		●	●	83962267
 Atraumatische Greifzange "Babcock", große distale Greif- fläche mit feiner Querverzahnung, doppelbeweglich, MTL= 42 mm <i>Atraumatic grasping forceps, "Babcock", large distal grasping surface with fine horizontal serration, double jaw action, JL= 42 mm</i>	8395.187	●		●	83951877
	8396187		●	●	83961877
 Atraumatische Greifzange, "Babcock", doppelbeweglich MTL= 38 mm <i>Atraumatic grasping forceps, "Babcock", doppel jaw action JL= 38 mm</i>	8395.214	●		●	83952148





* JL = Jaw length when jaws closed (approximate measurements)

* MTL = Maulteillänge bei geschlossenem Maulteil (gerundete Angaben)

ERAGON modular
modular Instruments 10 mm

ERAGON modular
modulare Instrumente 10 mm

 <p>Alle Innenteile und Schaffrohre sind ebenfalls mit ERAGONaxial kombinierbar. <i>All jaw inserts and sheaths can also be combined with ERAGONaxial.</i></p>	Griffvarianten / Handle type		Drehradaufsatz, ERAGONaxial Knob attachment, ERAGONaxial
			
Typen / Types	83930082	83930085	8988



Innenteil / Jaw insert	Schaffrohr, unisoliert Sheath tube, uninsulated		Griffvarianten / Handle type		Komplett-Instrument • Innenteil • Schaffrohr • Handgriff Complete instrument • Jaw insert • Sheath tube • Handle
	Typen / Types	NL / WL 330 mm	NL / WL 450 mm	83930072	
 MTL / JL*	8395.234	●		●	83952347
Tellerfazzange, doppelbeweglich, MTL= 50 mm <i>Plate-shaped grasping forceps, double jaw action, JL= 50 mm</i>	8396234		●	●	83962347
	8395.236	●		●	83952368
Greifzange mit Hechtmaul, doppelbeweglich, MTL= 20 mm <i>Grasping forceps with alligator jaws, double jaw action, JL= 20 mm</i>	8396236		●	●	83962367
	8395.204	●		●	83952048
Greifzange, 2/3 krallig, MTL= 49 mm <i>Grasping forceps, 2/3 claws, JL= 49 mm</i>	8396204		●	●	83962047
	8395490	●		●	83954907
Krallengreifzange, mit zusätzlicher Zahnreihe, doppelbeweglich, MTL= 38 mm <i>Claw-type grasping forceps, with an additional row of teeth, double jaw action, JL= 38 mm</i>					

* JL = Jaw length when jaws closed (approximate measurements)





* MTL = Maulteillänge bei geschlossenem Maulteil (gerundete Angaben)

ERAGON_{modular}
modular instruments 10 mm

ERAGON_{modular}
modulare Instrumente 10 mm

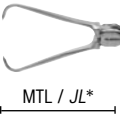
<p>ERAGON_{axial}</p> <p>Alle Innenteile und Schaffrohre sind ebenfalls mit ERAGONaxial kombinierbar. <i>All jaw inserts and sheaths can also be combined with ERAGONaxial.</i></p>	Griffvarianten / Handle type		Drehradaufsatz, ERAGONaxial Knob attachment, ERAGONaxial
			
Typen / Types	mit Sperre, drehbar <i>with locking mechanism, rotatable</i>	mit Sperre, nicht drehbar <i>with locking mechanism, not rotatable</i>	autoklavierbar / autoclavable
	83930082	83930085	8988

4

<p>Innenteil / Jaw insert</p> 	<p>Schaffrohr, unisoliert <i>Sheath tube, uninsulated</i></p> 	Griffvarianten / Handle type	<p>Komplett-Instrument</p> <ul style="list-style-type: none"> • Innenteil • Schaffrohr • Handgriff <p>Complete instrument</p> <ul style="list-style-type: none"> • Jaw insert • Sheath tube • Handle
			
Typen / Types	NL / WL 330 mm	83930072	Typen / Types
	8395.489	●	●
Krallegreifzange, doppelbeweglich, MTL = 38 mm <i>Claw grasping forceps, double jaw action, JL= 38 mm</i>			83954897
	8395.244	●	●
Löffelzange, MTL= 31 mm <i>Spoon forceps, JL= 31 mm</i>			83952448

* JL = Jaw length when jaws closed (approximate measurements)



* MTL = Maulteillänge bei geschlossenem Maulteil (gerundete Angaben)



ERAGON modular *micro*

modular scissors 2 mm

ERAGON modular *micro*

modulare Schere 2 mm

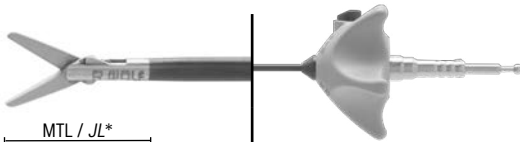
<p>Alle Innenteile und Schaftrohre sind ebenfalls mit ERAGONaxial kombinierbar. <i>All jaw inserts and sheaths can also be combined with ERAGONaxial.</i></p>	<p>Griffvarianten / <i>Handle type</i></p>  <p>ohne Sperre, drehbar <i>without locking mechanism, rotatable</i></p>	<p>Drehradaufsatz, ERAGONaxial Knob attachment, ERAGONaxial</p>  <p>autoklavierbar / <i>autoclavable</i></p>
	<p>Type / <i>Type</i></p>	<p>83930083</p>

<p>Innenteil mit isoliertem Schaftrohr <i>Jaw insert with insulated sheath tube</i></p>  <p>MTL / <i>JL*</i></p>	<p>Griffvarianten / <i>Handle type</i></p> <p>HF / mono </p> <p>ohne Sperre, drehbar <i>without locking mechanism, rotatable</i></p>	<p>Komplett-Instrument</p> <ul style="list-style-type: none"> • Innenteil mit Schaftrohr • Handgriff <p>Complete instrument</p> <ul style="list-style-type: none"> • <i>Jaw insert with sheath tube</i> • <i>Handle</i> 		
			<p>NL / <i>WL</i> 240 mm</p>	<p>Type / <i>Type</i></p>
<p></p> <p>Schere, gerade, doppelbeweglich, MTL= 7 mm Scissors, <i>straight, double jaw action</i> JL= 7 mm</p>	<p>8388200</p>	<p>●</p>	<p>●</p>	<p>83882007</p>

* JL = *Jaw length when jaws closed (approximate measurements)*



* MTL = *Maulteillänge bei geschlossenem Maulteil (gerundete Angaben)*







ERAGON modular mini

modular scissors 3.5 mm

ERAGON modular mini

modulare Scheren 3,5 mm

<p>ERAGON axial</p> <p>Alle Innenteile und Schaffrohre sind ebenfalls mit ERAGONaxial kombinierbar. All jaw inserts and sheaths can also be combined with ERAGONaxial.</p>	<p>Griffvarianten / Handle type</p>  <p>HF / mono</p> <p>ohne Sperre, drehbar without locking mechanism, rotatable</p>		<p>Drehradaufsatz, ERAGONaxial Knob attachment, ERAGONaxial</p>  <p>autoklavierbar / autoclavable</p>
	Typen / Types	83930083	8988

<p>Innenteil Jaw insert</p>  <p>MTL / JL*</p>	<p>Schaffrohr, isoliert Sheath tube, insulated</p> 		<p>Griffvarianten / Handle type</p>  <p>HF / mono</p> <p>ohne Sperre, drehbar without locking mechanism, rotatable</p>		<p>Komplett-Instrument</p> <ul style="list-style-type: none"> • Innenteil • Schaffrohr • Handgriff <p>Complete instrument</p> <ul style="list-style-type: none"> • Jaw insert • Sheath • Handle
	Typen / Types	NL / WL 240 mm	NL / WL 330 mm	83930073	
 <p>Schere "Metzenbaum", doppelbeweglich, MTL= 16 mm Scissors "Metzenbaum", double jaw action, JL= 16 mm</p>	8390215	●		●	83902157
	8391215		●	●	83912157
 <p>Schere "Metzenbaum", fein gezahnt, gebogen, doppelbeweglich, MTL= 14 mm Scissors „Metzenbaum“, fine serrated, curved, double jaw action, JL= 14 mm</p>	8390224	●		●	83902247
	8391224		●	●	83912247
 <p>Hakenschere, einfach beweglich, MTL= 8 mm Hook scissors, single jaw action, JL= 8 mm</p>	8390227	●		●	83902277
	8391227		●	●	83912277

* JL = Jaw length when jaws closed (approximate measurements)



* MTL = Maulteillänge bei geschlossenem Maulteil (gerundete Angaben)







ERAGON modular

modular scissors 5 mm

ERAGON modular

modulare Scheren 5 mm

<p>ERAGON axial</p> <p>Alle Innenteile und Schaftrohre sind ebenfalls mit ERAGONaxial kombinierbar. <i>All jaw inserts and sheaths can also be combined with ERAGONaxial.</i></p>	<p>Griffvarianten / Handle type</p>  <p>HF / mono</p> <p>ohne Sperre, drehbar <i>without locking mechanism, rotatable</i></p>		<p>Drehradaufsatz, ERAGONaxial <i>Knob attachment, ERAGONaxial</i></p>  <p>autoklavierbar / <i>autoclavable</i></p>
	<p>Typen / Types</p>	<p>83930083</p>	<p>8988</p>

<p>Innenteil <i>Jaw insert</i></p>  <p>MTL / JL*</p>	<p>Schaftrohr, isoliert <i>Sheath tube, insulated</i></p> 		<p>Griffvarianten / Handle type</p>  <p>HF / mono</p> <p>ohne Sperre, drehbar <i>without locking mechanism, rotatable</i></p>		<p>Komplett-Instrument</p> <ul style="list-style-type: none"> • Innenteil • Schaftrohr • Handgriff <p>Complete instrument</p> <ul style="list-style-type: none"> • Jaw insert • Sheath • Handle
	<p>NL / WL 330 mm</p>	<p>NL / WL 450 mm</p>	<p>Typen / Types</p>		
	<p>8393.041</p>	<p>●</p>		<p>●</p>	<p>83930417</p>
<p>Schere "Metzenbaum", links gebogen, doppelbeweglich, MTL= 23 mm <i>Scissors "Metzenbaum", curved left, double jaw action, JL= 23 mm</i></p>	<p>8394.041</p>		<p>●</p>	<p>●</p>	<p>83940417</p>
	<p>8393243</p>	<p>●</p>		<p>●</p>	<p>83932437</p>
<p>Schere "Metzenbaum", gebogen, doppelbeweglich, MTL= 21 mm <i>Scissors "Metzenbaum", curved, double jaw action, JL= 21.2 mm</i></p>	<p>8394243</p>		<p>●</p>	<p>●</p>	<p>83942437</p>
	<p>8393.044</p>	<p>●</p>		<p>●</p>	<p>83930447</p>
<p>Mikro-Schere "Metzenbaum", gebogen, doppelbeweglich, MTL= 18 mm <i>Micro-scissors "Metzenbaum", curved, double jaw action, JL= 18 mm</i></p>					

* JL = Jaw length when jaws closed (approximate measurements)

* MTL = Maulteillänge bei geschlossenem Maulteil (gerundete Angaben)

HF connecting cable see page BDE 163.



HF-Anschlusskabel siehe Blatt BDE 163.







ERAGON modular

modular scissors 5 mm

ERAGON modular

modulare Scheren 5 mm

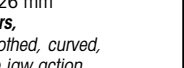
<p>ERAGON axial</p> <p>Alle Innenteile und Schaftrohre sind ebenfalls mit ERAGONaxial kombinierbar. <i>All jaw inserts and sheaths can also be combined with ERAGONaxial.</i></p>	<p>Griffvarianten / Handle type</p>  <p>HF / mono</p> <p>ohne Sperre, drehbar <i>without locking mechanism, rotatable</i></p>		<p>Drehradaufsatz, ERAGONaxial <i>Knob attachment,</i> ERAGONaxial</p>  <p>autoklavierbar / <i>autoclavable</i></p>
	<p>Typen / Types</p>	<p>83930083</p>	<p>8988</p>

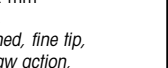
<p>Innenteil <i>Jaw insert</i></p>  <p>MTL / JL*</p>	<p>Schaftrohr, isoliert <i>Sheath tube, insulated</i></p> 		<p>Griffvarianten / Handle type</p>  <p>HF / mono</p> <p>ohne Sperre, drehbar <i>without locking mechanism, rotatable</i></p>		<p>Komplett-Instrument</p> <ul style="list-style-type: none"> • Innenteil • Schaftrohr • Handgriff <p>Complete instrument</p> <ul style="list-style-type: none"> • Jaw insert • Sheath • Handle
	<p>NL / WL 330 mm</p>	<p>NL / WL 450 mm</p>	<p>Typen / Types</p>		
 <p>Schere, schlank, gerade, doppelbeweglich, MTL= 20 mm Scissors, slimline, straight, <i>double jaw action,</i> JL= 20 mm</p>	<p>8393.045</p>	<p>●</p>	<p>●</p>	<p>●</p>	<p>83930457</p>
 <p>Schere, fein gezahnt, gebogen, doppelbeweglich, MTL= 26 mm Scissors, <i>fine-toothed, curved,</i> <i>double jaw action,</i> JL= 26 mm</p>	<p>8393246</p>	<p>●</p>	<p>●</p>	<p>●</p>	<p>83932467</p>
 <p>Schere, fein gezahnt, gebogen, doppelbeweglich, MTL= 26 mm Scissors, <i>fine-toothed, curved,</i> <i>double jaw action,</i> JL= 26 mm</p>	<p>8394246</p>	<p>●</p>	<p>●</p>	<p>●</p>	<p>83942467</p>
 <p>Schere, fein gezahnt, feine Spitze, doppelbeweglich, MTL= 22 mm Scissors, <i>fine-toothed, fine tip,</i> <i>double jaw action,</i> JL= 22 mm</p>	<p>8393248</p>	<p>●</p>	<p>●</p>	<p>●</p>	<p>83932487</p>
 <p>Schere, fein gezahnt, feine Spitze, doppelbeweglich, MTL= 22 mm Scissors, <i>fine-toothed, fine tip,</i> <i>double jaw action,</i> JL= 22 mm</p>	<p>8394248</p>	<p>●</p>	<p>●</p>	<p>●</p>	<p>83942487</p>

* JL = Jaw length when jaws closed (approximate measurements)

* MTL = Maulteillänge bei geschlossenem Maulteil (gerundete Angaben)



5



ERAGON modular

modular scissors 5 mm

ERAGON modular

modulare Schere 5 mm

<p>ERAGON axial</p> <p>Alle Innenteile und Schaftrohre sind ebenfalls mit ERAGONaxial kombinierbar. <i>All jaw inserts and sheaths can also be combined with ERAGONaxial.</i></p>	<p>Griffvarianten / Handle type</p> <p>HF / mono </p> <p>ohne Sperre, drehbar <i>without locking mechanism, rotatable</i></p>		<p>Drehradaufsatz, ERAGONaxial <i>Knob attachment,</i> ERAGONaxial</p> <p></p> <p>autoklavierbar / <i>autoclavable</i></p>
	Typen / Types	83930083	8988

<p>Innenteil <i>Jaw insert</i></p> <p></p> <p>MTL / JL*</p>	<p>Schaftrohr, isoliert <i>Sheath tube, insulated</i></p> <p>NL / WL 330 mm NL / WL 450 mm</p>		<p>Griffvarianten / Handle type</p> <p>HF / mono </p> <p>ohne Sperre, drehbar <i>without locking mechanism, rotatable</i></p>	<p>Komplett-Instrument</p> <ul style="list-style-type: none"> • Innenteil • Schaftrohr • Handgriff <p>Complete instrument</p> <ul style="list-style-type: none"> • Jaw insert • Sheath • Handle 	
	Typen / Types	8393933	8394933	83930073	Typen / Types
<p></p> <p>Hakenschere, gezahnt, einfach beweglich, MTL= 14 mm Hook scissors, serrated, single jaw action, JL= 14 mm</p>	8393.081	●	●	●	83930817
	8394.081		●	●	83940817

* JL = Jaw length when jaws closed (approximate measurements)



* MTL = Maulteillänge bei geschlossenem Maulteil (gerundete Angaben)

ERAGON *modu blades*

Modular "Metzenbaum" Scissors with single-use blades 5.5 mm

ERAGON *modu blades*

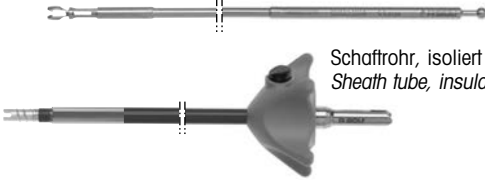
Modulare "Metzenbaum"-Schere mit Einmal-Aufsatz 5,5 mm

Innenteil / Jaw insert	Zugstange / Control rod						Handgriff / Handle	Komplett-Instrument • Innenteil • Schaffrohr • Handgriff Complete instrument • Jaw insert • Sheath tube • Handle
	NL / WL 260 mm		NL / WL 330 mm		NL / WL 450 mm			
	Zugstange Control rod	Schaffrohr Sheath tube	Zugstange Control rod	Schaffrohr Sheath tube	Zugstange Control rod	Schaffrohr Sheath tube	ohne Sperre, drehbar without locking mechanism, rotatable	
Typen / Types	8392934	8392935	8393934	8393935	8394934	8394935	83930073	Typen / Types
 MTL / JL 18 mm*								
 Schaffrohr, isoliert Sheath tube, insulated								
 Scherenaufsatz „Metzenbaum“ Einmalartikel, VE=10 ST, einzeln steril verpackt Scissors insert „Metzenbaum“ , single use article, PACK=10 PCS, sterile, individual packaging	4393.040	●	●				●	83920407
	4393.040			●	●		●	83930407
	4393.040					●	●	83940407

* JL = Jaw length when jaws closed (approximate measurements)

* MTL = Maulteillänge bei geschlossenem Maulteil (gerundete Angaben)

ERAGON <i>axial</i> Alle Maulteile und Schaffrohre sind ebenfalls mit ERAGONaxial kombinierbar. All jaw inserts and sheaths can also be combined with ERAGONaxial .	Handgriff / Handle	
		 HF / mono
	ohne Sperre, drehbar without locking mechanism, rotatable	83930083

Optional:

Knob attachment,

ERAGON axial autoclavable 8988



Optional:

Drehradaufsatz

ERAGON axial, autoklavierbar 8988

THE BEST OF BOTH WORLDS

Our popular modular "Metzenbaum" Scissors provide an effective combination of single-use and reusable components:

These scissors offer the outstanding cutting quality of single-use scissors, but the low proportion of disposable material makes these scissors much more cost-effective than single-use scissors. Insulation extending over the joint mechanism also offers additional safety, e.g. for dissection close to organs with monopolar HF current. The reusable shaft and handle guarantees high stability and long life. They also bring about a major reduction in running costs.



HF connecting cable see page BDE 163.

THE BEST OF BOTH WORLDS

Unsere beliebte modulare "Metzenbaum"-Schere ist eine sinnvolle Kombination aus Einweg- und Mehrwegkomponenten:

Sie bietet die hervorragende Schneidequalität einer Einwegscheren, ist durch den geringen Einweganteil aber wesentlich ökonomischer als diese. Eine bis über die Gelenkmechanik reichende Isolation bietet dabei zusätzliche Sicherheit z.B. bei der organnahen Präparation mit monopolarer HF-Strom. Durch die wiederverwendbaren Trägerkomponenten, die höchste Stabilität und Lebensdauer garantieren, werden laufende Kosten extrem reduziert.

HF-Anschlusskabel siehe Blatt BDE 163.

ERAGON modular

Accessories

ERAGON modular

Zubehör

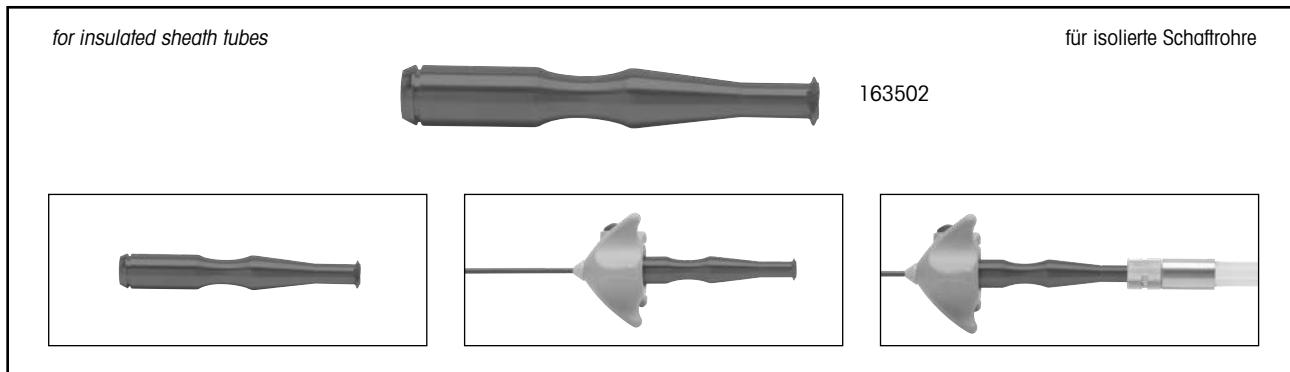

For manual and machine Reprocessing:

Irrigation adapter,
Ø 9 mm, length 64 mm
for insulated sheath tubes 163502

Für manuelle und maschinelle Aufbereitung:

Spüladapter,
Ø 9 mm, Länge 64 mm
für isolierte Schaftröhre 163502

5

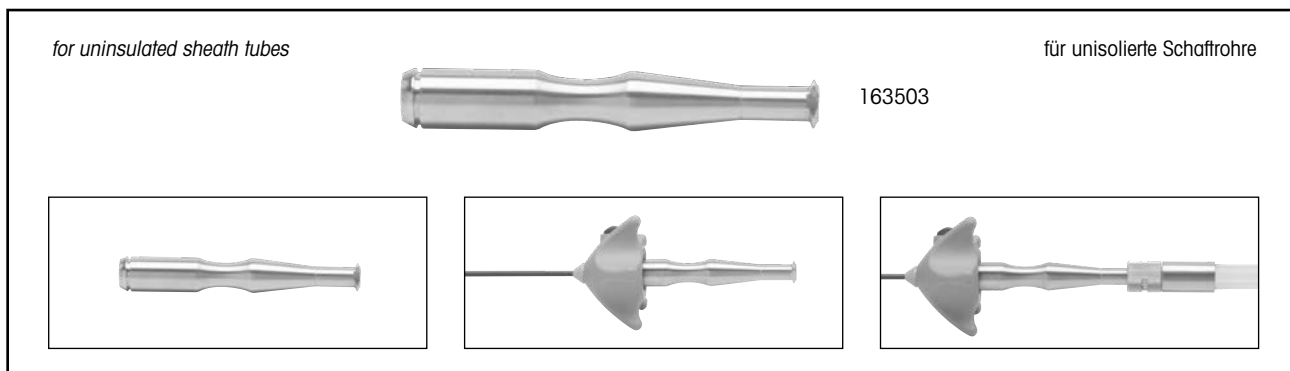

For manual and machine Reprocessing:



Irrigation adapter,
Ø 9 mm, length 64 mm
for uninsulated sheath tubes 163503





Für manuelle und maschinelle Aufbereitung:

Spüladapter,
Ø 9 mm, Länge 64 mm
für unisolierte Schaftröhre 163503

Handle Type
for modular systems

Griffvarianten
für modulare Systeme

Griffvarianten / Handle type ERAGON ^{modular}	drehbar mechanism, rotatable	mit Sperre with locking	ohne Sperre without locking	mit HF with HF	ohne HF without HF	Typen Types
	•	•			•	83930072
	•		•	•		83930073
	•	•		•		83930074

Griffvarianten / Handle type ERAGON ^{axial}	drehbar mechanism, rotatable	mit Sperre with locking	ohne Sperre without locking	mit HF with HF	ohne HF without HF	Typen Types
	•	•			•	83930082
	•		•	•		83930083
	•	•		•		83930084
		•			•	83930085



Optional zu 83930082 / 83930083 / 83930084:
Drehradaufsatz ERAGON axial, autoklavierbar 8988

Optional for 83930082 / 83930083 / 83930084:
Knob attachment, ERAGON axial autoclavable 8988

All **ERAGON**^{modular} components are compatible with **ERAGON**^{axial}

Alle **ERAGON**^{modular} Komponenten sind mit **ERAGON**^{axial} kompatibel.

Handle Type
for modular systems

Griffvarianten
für modulare Systeme

Griffvarianten / Handle type	nicht drehbar mechanism, not rotatable	mit Sperre with locking	mit HF with HF	ohne HF without HF	Typen Types
axial / axial 	●	●		●	8393.941





Bipolar Forceps 3.5 mm

with spring handle
modular system

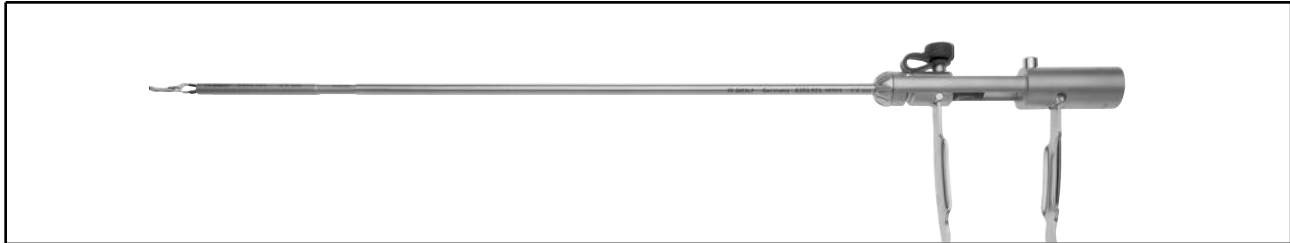
Bipolar-Zange 3,5 mm

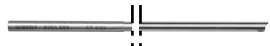
mit Federgriff
modulares System



<p>Innenteil / Jaw insert</p> 	<p>Außenrohr / Outer tube</p> 		<p>Schraubkappe mit Hülse Screw-on cap with sleeve</p> 	<p>Federgriff Spring handle</p> 	<p>Komplett-Instrument</p> <ul style="list-style-type: none"> • Innenteil • Außenrohr • Schraubkappe • Federgriff <p>Complete instrument</p> <ul style="list-style-type: none"> • Jaw insert • Outer tube • Screw-on cap • Spring handle 	
	Typen / Types	8390.921	8391.921	8393.978	8393.975	Typen / Types
 <p>Bipolar-Pinzette Bipolar forceps</p>	8391.715		●	●	●	8391.742

Spare parts:

Rubber cap 15220.019
Luer sealing cap 15023.153

Ersatzteile:







Gummikappe 15220.019
Luer-Verschlusskappe 15023.153

Bipolar Forceps 5 mm

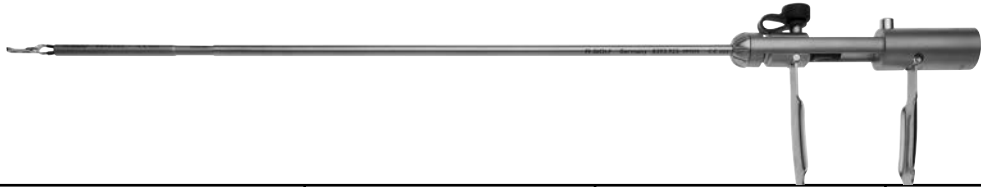
with spring handle
modular system

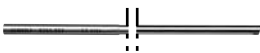
Bipolar-Zange 5 mm

mit Federgriff
modulares System

					
Innenteil / Jaw insert 	Schubhülse / Sliding sleeve 	Außenrohr / Outer tube 	Federgriff Spring handle 	Komplett-Instrument • Innenteil • Schubhülse • Außenrohr • Federgriff Complete instrument • Jaw insert • Outer tube • Screw-on cap • Spring handle	
Typen / Types	NL / WL 300 mm 8393.923	NL / WL 300 mm 8393.925	8393.975	Type / Type	
 Bipolar-Greifzange, Kleppinger Prinzip Bipolar grasping forceps, Kleppinger principle	8393.714	●	●	●	8393.741

Spare parts:

Rubber cap 15220.019
Luer sealing cap 15023.153

Bipolar connecting cable see page BDE 164.

Ersatzteile:

Gummikappe 15220.019
Luerverschlusskappe 15023.153

Bipolar-Anschlusskabel siehe Blatt BDE 164.









ERAGON bipolar

modular bipolar instruments, 5.5 mm,
rotatable

ERAGON bipolar

modulare Bipolar-Instrumente, 5,5 mm,
drehbar



Innenteil <i>Jaw insert</i>	Schaftrohr <i>Sheath tube</i>		Handgriff, drehbar <i>Handle, rotatable</i>	Komplett • Innenteil • Schaftrohr • Handgriff <i>Complete</i> • Jaw insert • Sheath • Handle	
	Typen / Types	NL / WL 330 mm			NL / WL 460 mm
					
	Typen / Types	83930921	82340024	839300102	Typen / Types
 Greif- und Präparierzange, MTL= 21 mm Grasping and preparation forceps, JL= 21 mm	83930031	•		•	839300312
	839400310		•	•	839400312
 Greif- und Dissektionszange "Maryland-Dissektor", MTL= 23 mm Grasping and dissecting forceps "Maryland-Dissektor", JL= 23 mm	83930032	•		•	839300322
	839400320		•	•	839400322
 Greif- und Dissektionszange "Dolphin", MTL= 21 mm Grasping and dissecting forceps "Dolphin", JL= 21 mm	83930033	•		•	839300332
	839400330		•	•	839400332
 Fasszange, gefenestert, MTL= 23 mm Grasping forceps, fenestrated, JL= 23 mm	83930034	•		•	839300342
	839400340		•	•	839400342
 Präparierzange "Hasskamp", MTL= 19 mm Dissecting forceps "Hasskamp", JL= 19 mm	83930035	•		•	839300352
	839400350		•	•	839400352
 Sterilisationszange "Hasskamp", MTL= 19 mm Sterilisation forceps "Hasskamp", JL= 19 mm	83930036	•		•	839300362
	839400360		•	•	839400362

* JL = Jaw length when jaws closed (approximate measurements)

* MTL = Maulteillänge bei geschlossenem Maulteil (gerundete Angaben)





ERAGON bipolar

modular bipolar instruments, 5.5 mm,
rotatable

ERAGON bipolar

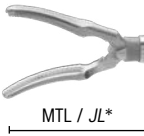
modulare Bipolar-Instrumente, 5,5 mm,
drehbar





Innenteil Jaw insert  MTL / JL*	Schaftrohr Sheath NL / WL 330 mm 460 mm		Handgriff, drehbar Handle, rotatable 	Komplett • Innenteil • Schaftrohr • Handgriff Complete • Jaw insert • Sheath • Handle
	Typen / Types			Typen / Types
Greif- und Dissektionszange "Münster" , MTL= 22 mm <i>Grasping and dissecting forceps "Münster"</i> JL= 22 mm 	83930037	●	●	839300372
Greif- und Dissektionszange "Maryland", kurz MTL= 15 mm <i>Grasping and dissecting forceps "Maryland", short</i> , JL= 15 mm 	83930038	●	●	839300382
	839400380	●	●	839400382
	83930041	●	●	839300412
Metzenbaumschere , MTL= 22 mm <i>Metzenbaum scissors</i> , JL= 22 mm	839400410	●	●	839400412

* JL = Jaw length when jaws closed (approximate measurements)

* MTL = Maulteillänge bei geschlossenem Maulteil (gerundete Angaben)

Electrodes 2 mm
monopolar

Elektroden 2 mm
monopolar





		
	NL / WL 400 mm	Type / Type
 Koagulations-Knopf-Elektrode <i>Coagulation button electrode</i>	●	823.06

7

*Electrodes 3.5 mm
monopolar*

*Elektroden 3,5 mm
monopolar*



	NL / WL 240 mm	NL / WL 340 mm	Typen / Types
 Haken-Elektrode <i>Hook electrode</i>		●	8379.452
 Hakenelektrode <i>monopolar, mit distal verlängerter Isolation</i> Hook electrode <i>monopolar, with distal extended insulation</i>	●		8785.642
 Nadel-Elektrode <i>Needle electrode</i>		●	8379.482
 Koagulations-Knopf-Elektrode <i>Coagulation button electrode</i>		●	8379.462

7





HF connecting cable see page BDE 163.

HF-Anschlusskabel siehe Blatt BDE 163.

Electrodes 5 mm
monopolar

Elektroden 5 mm
monopolar



	NL / WL 340 mm	NL / WL 420 mm	Typen / Types
	●		8383.423
Haken-Elektrode <i>Hook electrode</i>		●	8384.423
	●		8383.426
Nadel-Elektrode <i>Needle electrode</i>			8383.428
	●		8383.428
Spatel-Elektrode <i>Spatula electrode</i>			8383429
	●		8383429
Myom Dissektor <i>Myoma dissector</i>			



7

HF connecting cable see page BDE 163.

HF-Anschlusskabel siehe Blatt BDE 163.

Button Electrodes 5 mm
monopolar

Knopf-Elektroden 5 mm
monopolar



		
	NL / WL 450 mm	Typen / Types
 Knopf-Elektrode <i>Button electrode</i>	●	8384.40

HF connecting cable see page BDE 163.

HF-Anschlusskabel siehe Blatt BDE 163.

BipoTrode
1.6 mm / 5 Fr. Bipolar Electrode

BipoTrode
1,6 mm / 5 Charr. Bipolar-Elektrode

		
	GL / TL 360 mm	Typen / Types
	●	823005
<p>BipoTrode Bipolar-Elektrode BipoTrode bipolar electrode</p>		

7

- For precise dissection, preparation and coagulation using saline distension media, also for use in laparoscopy (e.g. in combination with trocar sleeve 8309.072 with trocar 8309.121)
- Small diameter of 5 Fr. allows use with hysteroscopes
- Made of semiflexible stainless steel so can be used with bent working channels but preferably with straight working channels of the compact R. WOLF hysteroscopes
- Robust and ergonomic handle
- Autoclavable and reusable

- Zur Dissektion, Präparation und Koagulation in der Hysteroskopie, auch in der Laparoskopie einsetzbar (passend z.B. zu Trokarhülse 8309.072 mit Trokar 8309.121)
- Sehr filigrane Abmessungen zur Anwendung durch klassische Hysteroskope mit 5 Charr. Arbeitskanal
- Durch Verwendung semielastischen Stahls sowohl durch gerade als auch durch schräg zulaufende Arbeitskanäle anwendbar
- Stabiler und ergonomischer Handgriff für einfaches Handling
- Autoklavierbar und somit wiederverwendbar

Bipolar tweezers connecting cable see page BDE 164.

Bipolar-Pinzettenanschlusskabel siehe Blatt BDE 164.

Multifunction Suction-Irrigation System

possible combinations

Multifunktionelles Saug-Spül-System

Kombinationsmöglichkeiten

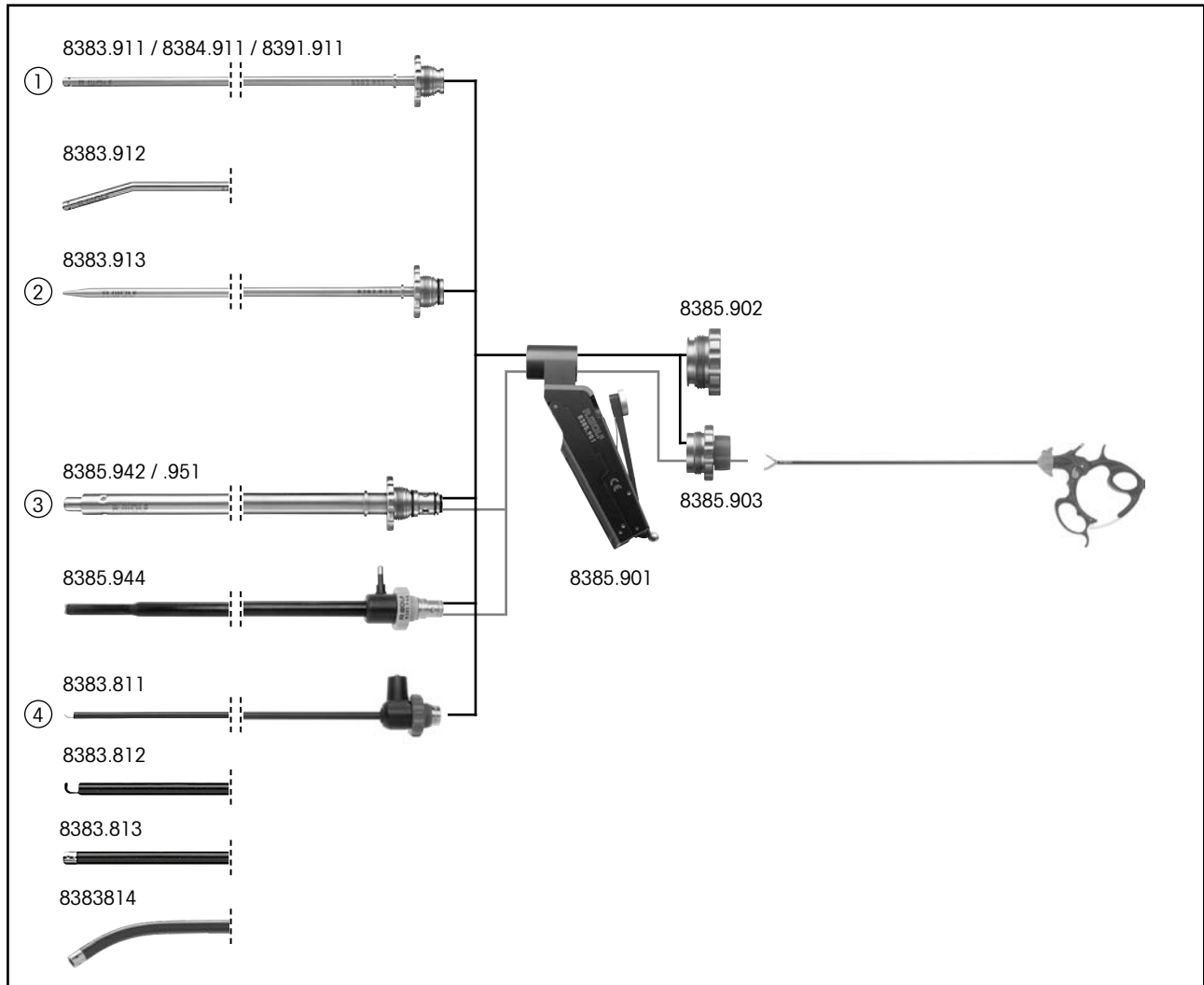

① **Suction or irrigation:**

Suction-irrigation tubes 8383.911, 8384.911, 8391.911
 Suction-irrigation tube, angled (thoracoscopy) 8383.912
 also: sealing cap 8385.902

② **Blunt aquadissection:**

Pressure irrigation tube 8383.913
 also: sealing cap 8385.902

③ **Suction, irrigation and use of 5 mm auxiliary instruments:**

Suction-irrigation tube 8385.942 / .951
 Suction-irrigation tube, insulated, with atraumatic dissection tip 8385.944
 also: sealing adapter 8385.903

④ **Tissue dissection with HF:**

HF spatula probe 8383.811
 HF hooked probe 8383.812
 HF button electrode 8383.813
 HF suction and irrigation tube, curved 8383814
 also: sealing cap 8385.901

① **Saugen oder Spülen:**

Saug-Spülrohre 8383.911, 8384.911, 8391.911
 Saug-Spülrohr, gebogen (Thorakoskopie) 8383.912
 hierzu: Verschlusskappe 8385.902

② **Stumpfe Aquadisektion:**

Druck-Spülrohr 8383.913
 hierzu: Verschlusskappe 8385.902

③ **Saugen, Spülen und Anwendung von Hilfsinstrumenten ø 5 mm:**

Saug-Spülrohre 8385.942 / .951
 Saug-Spülrohr, isoliert, mit atraumatischer Präparierspitze 8385.944
 hierzu: Dichtaufsatz 8385.903

④ **Präparation von Gewebe mit HF:**

HF-Spatelsonde 8383.811
 HF-Hakensonde 8383.812
 HF-Knopfelektrode 8383.813
 HF-Saug-Spül-Rohr, gebogen 8383814
 hierzu: Verschlusskappe 8385.902

Multifunction Suction-Irrigation System

suction-irrigation handle

Multifunktionelles Saug-Spül-System

Saug-Spül-Handgriff



- Autoclavable
- Durable
- Low long-term costs
- Universal applications
- Interfaces for various attachments
- Large lumen for efficient irrigation and suction

- Autoklavierbar
- Hoher Dauergebrauchswert
- Niedrige Langzeitkosten
- Universelle Einsetzbarkeit
- Schnittstelle für verschiedene Aufsätze
- Großes Lumen für effizientes Spülen und Saugen

Suction-irrigation handle 8385.901

Saug-Spül-Handgriff 8385.901

Sealing cap 8385.902

Verschlusskappe 8385.902

Required to use \varnothing 5 mm auxiliary instruments:

Notwendig bei Anwendung von Hilfsinstrumenten \varnothing 5 mm:

Sealing attachment with opening and membrane valve 8385.903

Dichtaufsatz mit Durchgang und Membranventil 8385.903

Spare membrane valve 89.103

Ersatz-Membranventil 89.103

Suction-Irrigation Tube Sets

Saug-Spül-Schlauchsets

Reusable

Mehrmalgebrauch

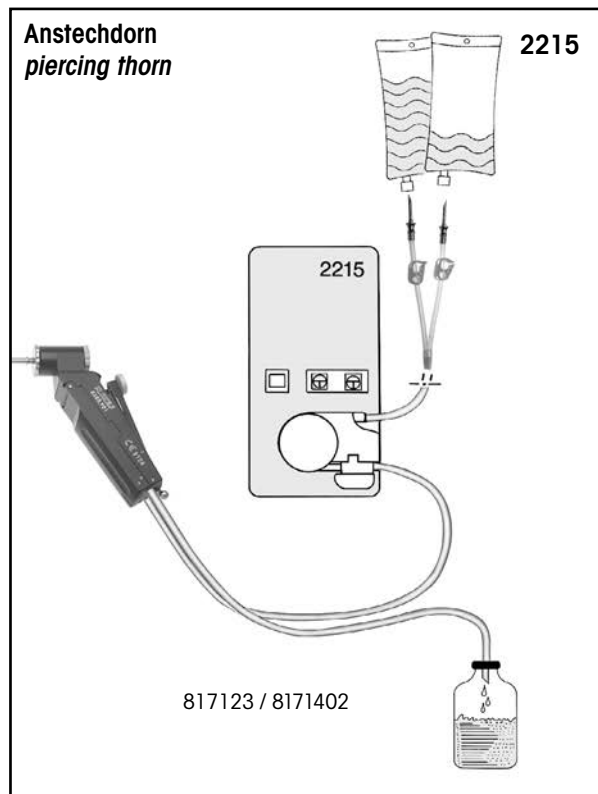

Schlauchansatz

mit Luer-Lock-Anschluss,
für Saug-Spül-Handgriff 8385.901
und Schlauchset 8171223 oder 8170.223,
wiederverwendbar 817123

Saugschlauch

3 m, für Saug-Spül-Handgriff 8385.901,
wiederverwendbar 8171402

Tube attachment

with luer-lock connector,
for suction-irrigation handle 8385.901
and tube set 8171223 or 8170.223,
reusable 817123

Suction tube

3 m, for suction-irrigation handle 8385.901,
reusable 8171402

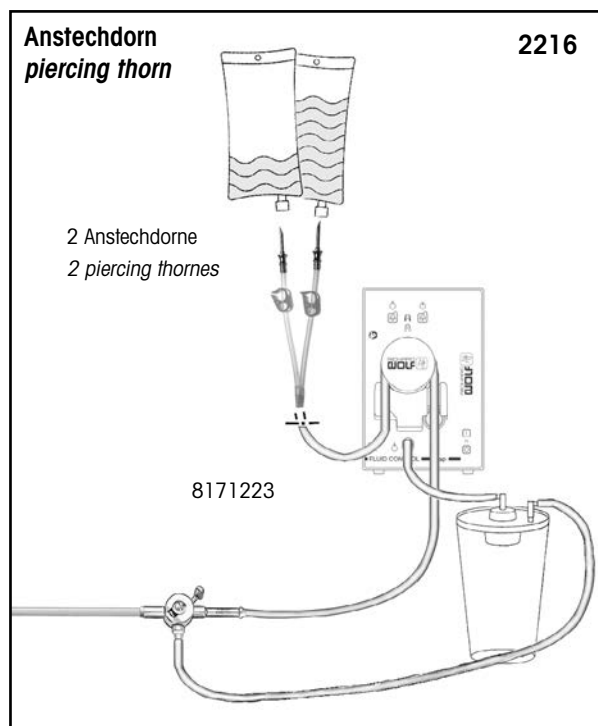

Schlauchset mit Anstechdorn,

mit Luer-Lock Anschluss,
autoklavierbar, incl. 10 Ersatzmembranen, wiederverwendbar
für 20 Aufbereitungszyklen,
für FLUID CONTROL LAP 2216 8171223

Tubing set with piercing connector,

with luer-lock connector,
autoclavable, incl. 10 replacement membranes,
reusable for 20 reprocessing cycles,
for FLUID CONTROL LAP 2216 8171223

Vakuum-Schlauch

von Pumpe zu Sekretbehälter 8170.401

Vacuum tube

from pump to secretion trap 8170.401

Suction-Irrigation Tube Sets

Saug-Spül-Schlauchsets

Disposable

Einmalgebrauch

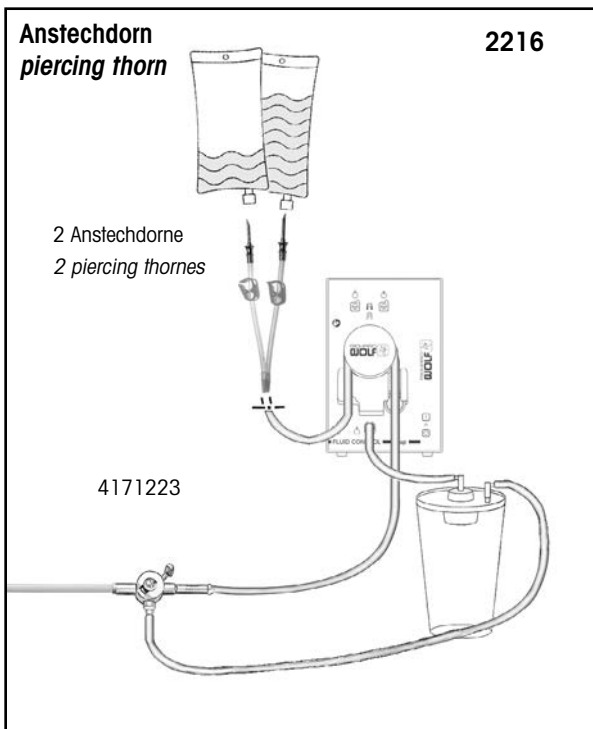

Schlauchset mit Anstechdorn,
mit Luer-Lock Anschluss,
steriler Einmalartikel, VE=10 ST,
für FLUID CONTROL LAP 2216 4171223

Tubing set with piercing connector,
with luer-lock connector,
sterile single use item, PACK=10 PCS
für FLUID CONTROL LAP 2216 4171223

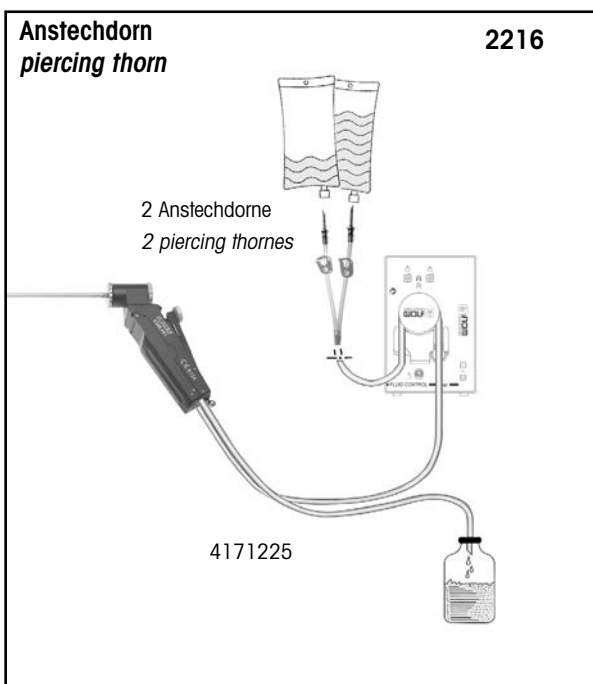

Schlauchset mit Anstechdorn,
mit Anschlussstück für Saug-Spül-Handgriff (8385.901),
inkl. Ablaufschlauch, steriler Einmalartikel, VE=10 ST,
für FLUID CONTROL LAP 2216 4171225

Tubing set with piercing connector,
with connector for suction-irrigation handle (8385.901),
incl. drain tube, PACK=10 PCS
für FLUID CONTROL LAP 2216 4171225

Suction-Irrigation Tube Sets

Saug-Spül-Schlauchsets

Disposable

Einmalgebrauch

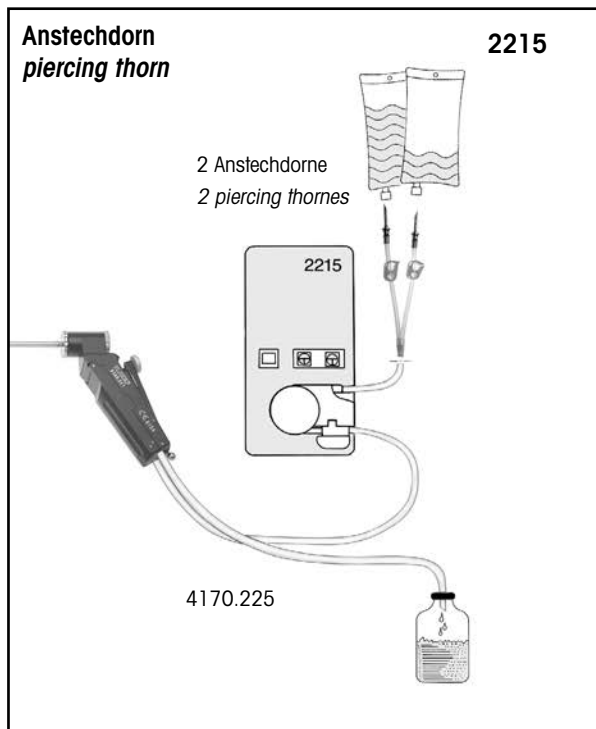

Schlauchset

PVC, mit 2 Anstechdornen

Einmalartikel

VE=10 ST, einzeln steril verpackt 4170.225

Tube set

PVC, with 2 piercing thorns

disposable

PACK=10 PCS, packed singly, sterile 4170.225

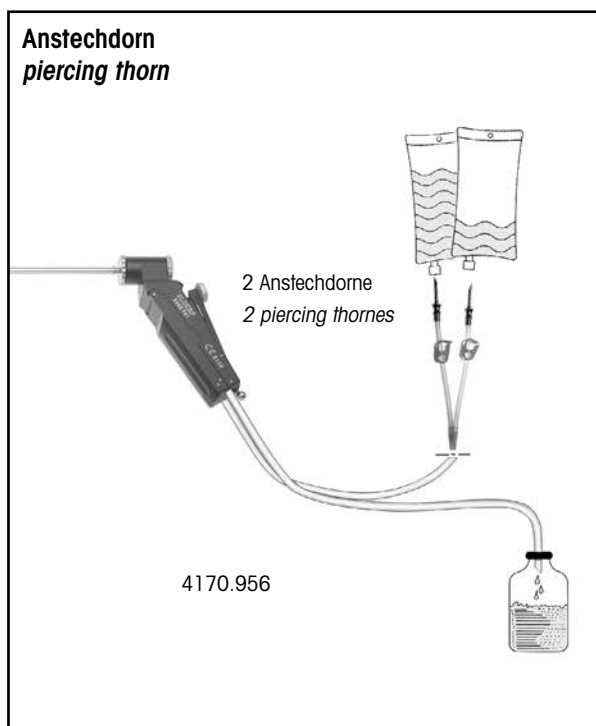

Saug-Spül-Schlauchset,

mit 2 Anstechdorne,

VE=10 ST, einzeln steril verpackt 4170.956

Suction-irrigation tube set,

with 2 piercing thorns

PACK=10 PCS, packed singly, sterile 4170.956

Suction-Irrigation Tube Sets

Saug-Spül-Schlauchsets

Disposable

Einmalgebrauch

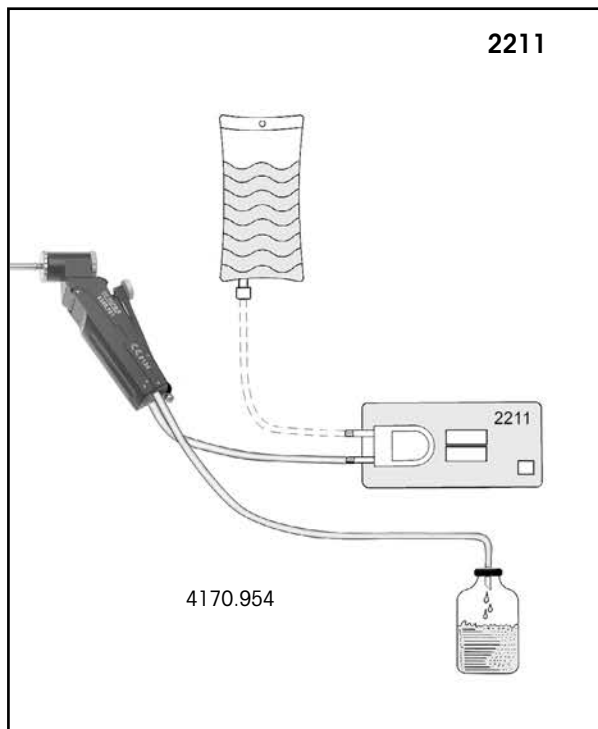

Saug-Spül-Schlauchset,
mit Luer-Lock,
VE=10 ST, einzeln steril verpackt 4170.954

Suction-irrigation tube set,
with Luer-lock,
PACK=10 PCS, packed singly, sterile 4170.954

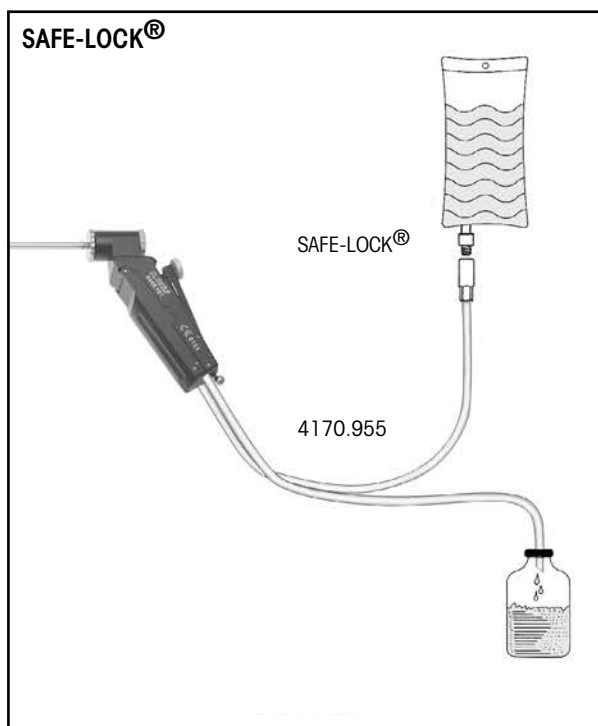

Saug-Spül-Schlauchset,
mit SAFE-LOCK®,
VE=10 ST, einzeln steril verpackt 4170.955

Suction-irrigation tube set,
with safe-lock®,
PACK=10 PCS, packed singly, sterile 4170.955

Suction-Irrigation Tube Sets

Saug-Spül-Schlauchsets

Disposable

Einmalgebrauch

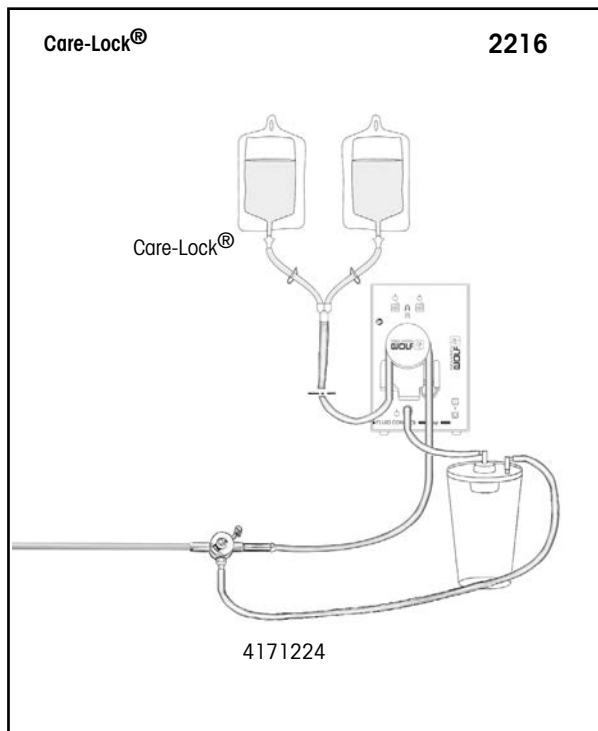





Schlauchset mit Care-Lock®,
steriler Einmalartikel, VE=10 ST,
für FLUID CONTROL LAP 2216 4171224

Tubeing set with Care-Lock®,
sterile single use item, PACK=10 PCS,
for FLUID CONTROL LAP 2216 4171224



Multifunction Suction-Irrigation System
Suction-irrigation tubes

Multifunktionelles Saug-Spül-System
Saug-Spül-Rohre

	Ø	NL / WL	Typen / Types
			
 Saug-Spül-Rohr Suction-irrigation tube	3.5 mm	300 mm	8391.911
 Saug-Spül-Rohr Suction-irrigation tube	5 mm	310 mm	8383.911
	5 mm	450 mm	8384.911
	5 mm	310 mm distal gebogen / curved distal tip	8383.912
 Druck-Spülrohr Irrigation tube for aquadissection	5 mm	310 mm	8383.913

For use of 5 mm auxiliary instruments

Zur Anwendung von 5 mm Hilfsinstrumenten







 Saug-Spül-Rohr Suction-irrigation tube	Ø 10 mm Durchlass 5 mm / capacity 5 mm	225 mm	8385.942
	Ø 10 mm Durchlass 5 mm / capacity 5 mm	330 mm	8385.951
 Saug-Spül-Rohr nach Buess, isoliert, mit atraumatischer Präparierspitze Suction-irrigation tube by Buess, insulated, with atraumatic dissection tip	Ø 10 mm Durchlass 5 mm / capacity 5 mm	330 mm	8385.944
notwendig zu 8385.951: Dichtaufsatz mit Durchgang und Membranventil Ersatz-Membran-Ventil (89.103) required for 8385.951: Sealing attachment with opening and membran valve Spare membrane valve (89.103)			8385.903

Multifunction Suction-Irrigation System

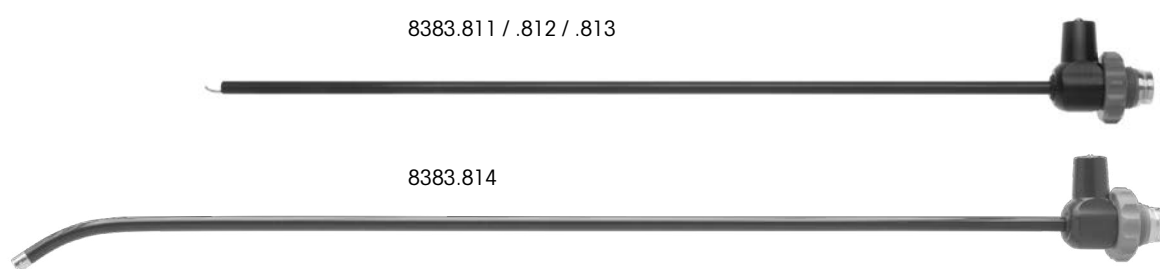
HF instruments, monopolar,
with suction and irrigation channel

Multifunktionelles Saug-Spül-System

HF-Instrumente, monopolar,
mit Saug- und Spülkanal



			
	∅	NL / WL	Typen / Types
 HF-Spatelsonde <i>HF spatula probe</i>			8383.811
 HF-Hakenelektrode <i>HF hook electrode</i>	5 mm	315 mm	8383.812
 HF-Knopfelektrode <i>HF button electrode</i>			8383.813
 HF-Saug-Spül-Rohr, gebogen <i>HF suction and irrigation tube, curved</i>	5.4 mm	380 mm	8383814
alternativ zum Saug-Spül-Handgriff: <i>as an alternative to the suction-irrigation handle:</i>	mit wartungsfreiem Zweiwegehahn, für multifunktionales Saug-Spül-System, wiederverwendbar <i>with maintenance-free two-way stopcock, for multifunctional suction-irrigation system, reusable</i>		8583819
Saug-Spül-Ansatz <i>Suction-irrigation adapter</i>			



HF connecting cable see page BDE 163.

HF-Anschlusskabel siehe Blatt BDE 163.

Suction-Irrigation Tubes 5 mm
with Luer connector

Saug-Spülrohre 5 mm
mit Luer-Anschluss

		
	NL / WL 300 mm	Type / Type
 Saug-Spülrohr mit Luer-Anschluss Durchlass 4 mm und distalen Öffnungen Suction-irrigation tube with Luer connector 4 mm capacity and distal openings	●	8383.51



		
	NL / WL 330 mm	Type / Type
 Saugrohr, mit Luer-Anschluss, Durchlass 3 mm Suction tube, with Luer connector, capacity 3 mm	●	8383.72

Suction Tube 5 mm

with Luer connector and one valve

Absaugrohr 5 mm

mit Luer-Anschluss und einem Ventil

		
	NL / WL 330 mm	Typen / Types
 Absaugrohr , graduert, mit 3-mm-Luer-Anschluss Suction tube , graduated, with Luer connector 3 mm	●	8383.68

Suction and Irrigation Tubes 5 mm



Saug-Spül-Rohre 5 mm



	NL / WL 290 mm	NL / WL 410 mm	Typen / Types
 Saug-Spül-Rohr mit wartungsfreiem Zweiwegehahn, Schaffrohr mit distalen Öffnungen, wiederverwendbar Suction-irrigation tube with maintenance-free two-way stopcock, sheath tube with distal openings, reusable	●		8583732
		●	8584732

*Combination Suction and
Irrigation Tube 5 mm
with two stop valves*

*Kombinations-Saug- und
Spülrohr 5 mm
mit zwei Absperrventilen*

		
	NL / WL 300 mm	Type / Type
 <p>Kombinations-Saug- und Spülrohr, mit Absperrventil <i>Combination suction and irrigation tube with stop valves</i></p>	●	8383.94

*Coagulation-Suction Tubes 5 mm
monopolar*

*Koagulations-Saugrohre 5 mm
monopolar*

with Luer connector and one valve



mit Luer-Anschluss und einem Ventil



	NL / WL 315 mm	NL / WL 450 mm	Typen / Types
 Koagulations-Saugrohr, mit Luer-Anschluss, Durchlass 3 mm Coagulation-suction tube, with Luer connector, capacity 3 mm	●		8383.71
		●	8384.71

Tissue Retractor 5 mm

Geweberetraktor 5 mm





		
	NL / WL 320 mm	Type / Type
 <p>Geweberetraktor, gerade <i>Tissue retractor, straight</i></p>	●	8383.691

- The extended hand of the surgeon*
- Held in one hand*
- Simple manipulation of tissue and organs*
- Better view of concealed or difficult to access areas*

- Verlängerte Hand des Chirurgen
- Einhandbedienung
- Problemloses Bewegen von Gewebe und Organen
- Besserer Einblick in verborgene oder schlecht zugängliche Bereiche

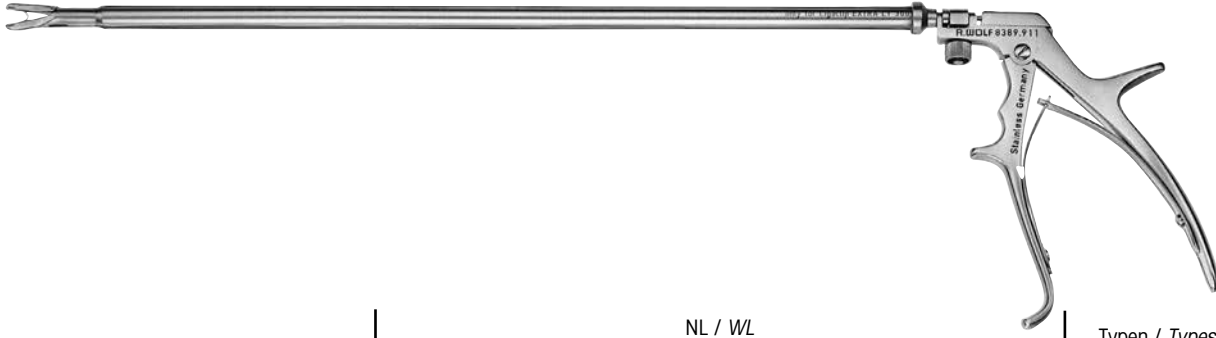
Clip Applicator 10 mm

Clip-Applikator 10 mm

		NL / WL 340 mm	Typen / Types
 Clip-Applikator Clip applicator		8389.911	
	hierzu: Einführhülse mit Dichtungskappe (89.08) also: Introducing sleeve with sealing cap (89.08)	8389.991	

For clip ligation with Ethicon® Ligaclip® EXTRA LT 300

Zur Clipunterbindung mit Ethicon® Ligaclip® EXTRA LT 300

Ethicon® Ligaclips®, PACK=108 PCS 8389.915







Ethicon® Ligaclips®, VE=108 Stück 8389.915

ERAGON_{stitch}

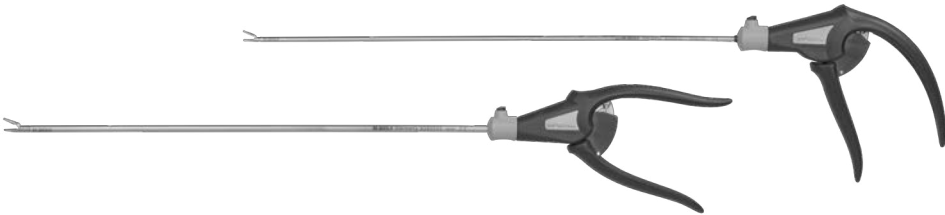
Needle Holder 3.5 mm
modular system

ERAGON_{stitch}

Nadelhalter 3.5 mm
modulares System

							
Nadelhalter-Innenteil Needle holder insert  MTL / JL*	Schaftrohr Sheath tube 		Griffvarianten / Handle type  axial  abgewinkelt / angled		Komplett-Instrument • Innenteil • Schaftrohr • Handgriff Complete instrument • Jaw insert • Sheath • Handle		
			einseitig beweglich, mit On-Off-Rastfunktion single movement, with on-off locking mechanism				
ERAGON _{stitch}	Typen / Types	SL 240 mm 8390533	SL 330 mm 8391533	8393943	8393944	Bestell-Nr. Order no.	
 Nadelhalter, gerade mit Hartmetalleinsatz MTL= 12 mm Modular needle holder, straight with carbide insert JL= 12 mm	8391505	●		●		83915053	
		●			●	83915054	
	8391506		●	●			83915063
			●			●	83915064

* JL = Jaw length when jaws closed (approximate measurements)

* MTL = Maulteillänge bei geschlossenem Maulteil (gerundete Angaben)



ERAGON *stitch*

Needle Holder 5 mm
modular system

ERAGON *stitch*

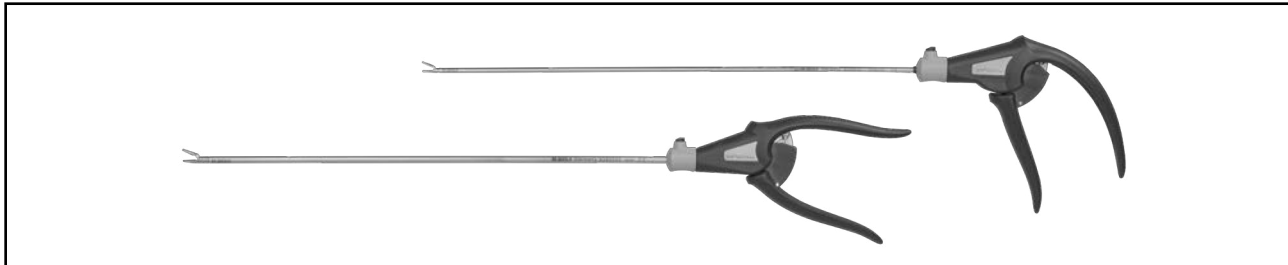
Nadelhalter 5 mm
modulares System



Nadelhalter-Innenteil Needle holder insert	Schaftrohr Sheath tube	Griffvarianten / Handle type		Komplett-Instrument • Innenteil • Schaftrohr • Handgriff Complete instrument • Jaw insert • Sheath • Handle		
		axial	abgewinkelt / angled			
		einseitig beweglich, mit On-Off-Rastfunktion single movement, with on-off locking mechanism		Bestell-Nr. Order no.		
ERAGON <i>stitch</i>	Typen / Types	SL 330 mm	SL 450 mm	8393943	8393944	
 MTL / JL*	8393507	●		●		83935073
		●			●	83935074
Nadelhalter , gerade mit Hartmetalleinsatz MTL= 19 mm Modular needle holder , straight with carbide insert JL= 19 mm	8394507		●	●		83945073
			●		●	83945074
 Nadelhalter , gerade, schmal mit Hartmetalleinsatz MTL= 19 mm Modular needle holder , straight, slim with carbide insert JL= 19 mm	8393508	●		●		83935083
		●			●	83935084
	8394508		●	●		83945083
			●		●	83945084
 Nadelhalter , gerade mit Aufrichtfunktion MTL= 19 mm Modular needle holder , straight with straightening up function JL= 19 mm	8393509	●		●		83935093
		●			●	83935094
	8394509		●	●		83945093
			●		●	83945094

* JL = Jaw length when jaws closed (approximate measurements)







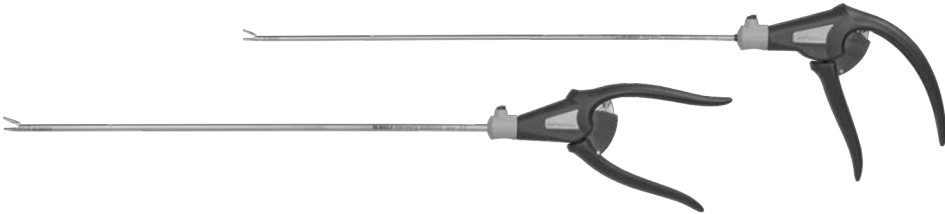

* MTL = Maulteillänge bei geschlossenem Maulteil (gerundete Angaben)

ERAGON *stitch*

Needle Holder 5 mm
modular system

ERAGON *stitch*

Nadelhalter 5 mm
modulares System

						
Nadelhalter-Innenteil Needle holder insert  MTL / JL*	Schaftrohr Sheath tube 	Griffvarianten / Handle type  axial  abgewinkelt / angled		einseitig beweglich, mit On-Off-Rastfunktion single movement, with on-off locking mechanism	Komplett-Instrument • Innenteil • Schaftrohr • Handgriff Complete instrument • Jaw insert • Sheath • Handle	
		Typen / Types	SL 330 mm 8393533		SL 450 mm 8394533	8393943 8393944
 Nadelhalter , rechts gebogen mit Hartmetalleinsatz MTL= 19 mm Modular needle holder , curved right with carbide insert JL= 19 mm	8393518	●		●		83935183
		●			●	
 Nadelhalter , links gebogen mit Hartmetalleinsatz MTL= 19 mm Modular needle holder , curved left with carbide insert JL= 19 mm	8394518		●	●		83945183
			●		●	
 Nadelhalter , links gebogen mit Hartmetalleinsatz MTL= 19 mm Modular needle holder , curved left with carbide insert JL= 19 mm	8393519	●		●		83935193
		●			●	
 Nadelhalter , links gebogen mit Hartmetalleinsatz MTL= 19 mm Modular needle holder , curved left with carbide insert JL= 19 mm	8394519		●	●		83945193
			●		●	

* JL = Jaw length when jaws closed (approximate measurements)

* MTL = Maulteillänge bei geschlossenem Maulteil (gerundete Angaben)

ERAGON_{stitch}
Accessories

ERAGON_{stitch}
Zubehör

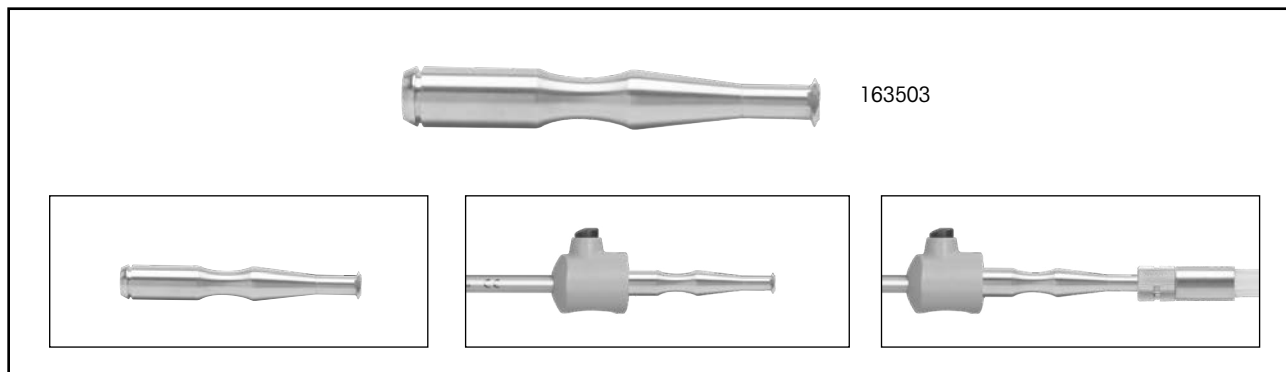

For manual and machine reprocessing:







Irrigation adapter,
Ø 9 mm, length 64 mm
for uninsulated sheath tubes 163503

Für manuelle und maschinelle Aufbereitung:

Spüladapter,
Ø 9 mm, Länge 64 mm
für unisolierte Schaftrohre 163503

Needle Holder 3.5 mm / 5 mm
modular system

Nadelhalter 3,5 mm / 5 mm
modulares System



Innenteil mit Schaffrohr und Spülanschluss <i>Inner section with sheath tube and irrigation tap</i>		Axialer Handgriff / Axial handle 		Komplett-Instrument • Innenteil mit Schaffrohr • Griff Complete instrument • Inner section with sheath tube • Handle		
		Typen / Types	Ø	SL / SL	8393.941	Typen / Types
 <p>Modularer Nadelhalter, gerade mit Hartmetalleinsatz Modular needle holder, straight with carbide insert</p>		8391.504	3.5 mm	340 mm	●	8391.501
 <p>Modularer Nadelhalter, gerade für gerade Nadeln Modular needle holder, straight for straight needles</p>		8393.504	5 mm	340 mm	●	8393.501
 <p>Modularer Nadelhalter, gerade mit Hartmetalleinsatz Modular needle holder, straight with carbide insert</p>		8393.505	5 mm	340 mm	●	8393.502
		8394.505	5 mm	430 mm	●	8394.502
 <p>Modularer Nadelhalter, rechts gebogen mit Hartmetalleinsatz Modular needle holder, curved right with carbide insert</p>		8393.514	5 mm	340 mm	●	8393.511
		8394.514	5 mm	430 mm	●	8394.511
 <p>Modularer Nadelhalter, links gebogen mit Hartmetalleinsatz Modular needle holder, curved left with carbide insert</p>		8393.515	5 mm	340 mm	●	8393.512
		8394.515	5 mm	430 mm	●	8394.512
 <p>Modularer Multifunktions*-Nadelhalter nach Sarbu Modular multifunction* needle holder by Sarbu</p>		8393.506	5 mm	340 mm	●	8393.503
		8394.506	5 mm	430 mm	●	8394.503

* with automatic needle alignment mechanism and cutting edge

* mit automatischer Nadelaufstellvorrichtung und Schneidkante

Needle Holder 5 mm

Nadelhalter 5 mm





<p>Axially aligned handle with locking mechanism</p> 	<p>Axialer Handgriff mit Rastmechanismus</p>	
	<p>NL / WL 310 mm</p>	<p>Typen / Types</p>
 <p>Nadelhalter, rechts gebogen nach Messroghli Needle holder, curved right by Messroghli</p>	<p style="text-align: center;">●</p>	<p>8383.534</p>





ERAGON modular

modular knot pusher 5 mm

ERAGON modular

modularer Knotenschieber 5 mm

<p>ERAGON axial</p> <p>Alle Innenteile und Schaftröhre sind ebenfalls mit ERAGONaxial kombinierbar. All jaw inserts and sheaths can also be combined with ERAGONaxial.</p>	Griffvarianten / Handle type				<p>Drehradaufsatz, ERAGONaxial Knob attachment, ERAGONaxial</p>  <p>autoklavierbar / autoclavable</p>
	 <p>mit Sperre, drehbar with locking mechanism, rotatable</p>	 <p>HF / mono ohne Sperre, drehbar without locking mechanism, rotatable</p>	 <p>HF / mono mit Sperre, drehbar with locking mechanism, rotatable</p>	 <p>mit Sperre, nicht drehbar with locking mechanism, not rotatable</p>	
Typen / Types	83930082	83930083	83930084	83930085	8988

<p>Innenteil / Jaw insert</p>  <p>MTL / JL*</p>	Schaftröhre, isoliert Sheath tube, insulated		Griffvarianten / Handle type		<p>Komplett-Instrument</p> <ul style="list-style-type: none"> • Innenteil • Schaftröhre • Handgriff <p>Complete instrument</p> <ul style="list-style-type: none"> • Jaw insert • Sheath • Handle
	 <p>NL / WL 330 mm</p>	<p>NL / WL 450 mm</p>	 <p>mit Sperre, drehbar with locking mechanism, rotatable</p>		
Typen / Types	8393933	8394933	83930072		Typen / Types
 <p>8393.345</p>	●		●		83933457
<p>Extrakorporaler Knotenschieber, mit distaler Aussparung, doppelbeweglich, MTL= 17 mm Extracorporeal knot pusher, with distal fork, double jaw action, JL= 17 mm</p> <p>8394345</p>		●	●		83943457

* JL = Jaw length when jaws closed (approximate measurements)

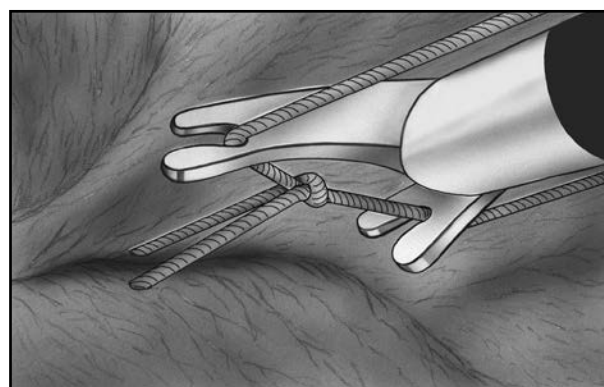

* MTL = Maulteillänge bei geschlossenem Maulteil (gerundete Angaben)





Extrakorporale Knotentechnik
Extracorporeal knotting technique

Knot Pusher 5 mm
for endoscopic suturing

Knotenschieber 5 mm
zum endoskopischen Nähen

		
	NL / WL 330 mm	Typen / Types
 Knotenschieber, für intraabdominale Knoten Knot pusher, for intra-abdominal knots	●	8383.55
 Knotenschieber, für extrakorporale Knoten Knot pusher, for extracorporeal knots	●	8383.551

11

		
	NL / WL 330 mm	Typen / Types
 Extrakorporaler Knotenschieber nach Bueß mit distaler Einkerbung und lateraler Öffnung zur optimalen Knotenführung, extrem atraumatische Spitze zur Benutzung als Taststab Extracorporeal knot pusher by Bueß with distal notch and lateral opening for optimum knotting, extremely atraumatic tip for use as probe	●	8383.552

Trocar-Site Closure Device for visualized Fascia Closure
by Busche

Endoskopisch kontrolliertes Faszienschluss-System nach Busche

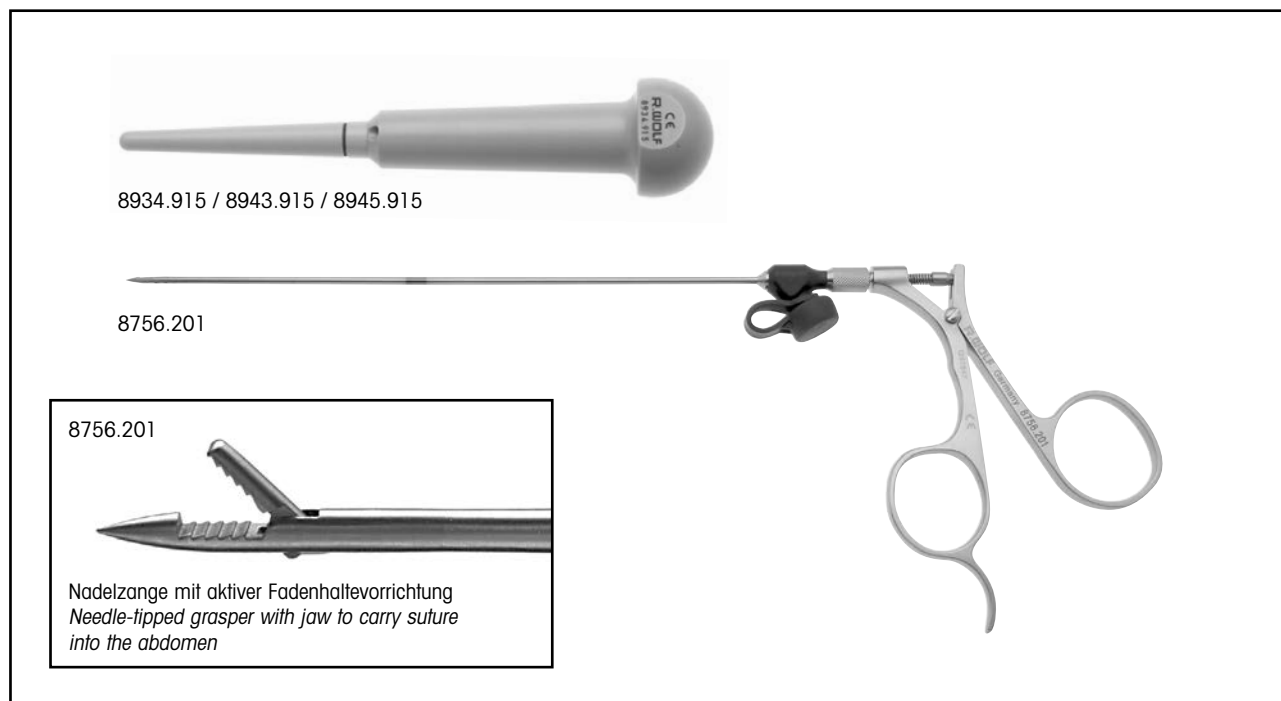

The extended tip of the device allows easy insertion of the cone which then effectively plugs the hole left when the cannula is removed. This preserves the pneumoperitoneum which can be maintained to ensure a safe distance between abdominal wall and the organs. The marking on the cone indicates the ideal position of placement for the ligature.

A suture is grasped with the special grasper and passed through the hole in the cone. This traverses the muscle, fascia and peritoneal layers. The suture is released inside the peritoneal cavity. To complete the stitch on the other side, the device is kept in place and turned through 180°. The grasper is reinserted and the intraperitoneal end of the suture is grasped and withdrawn from the peritoneal cavity as the cone is removed. The suture is tied extracorporeal under direct visual control.

Additional application is suture ligation of bleeding inferior epigastric vessels by using just the needle tipped grasper.

Closure cone

10 - 12 mm	8934.915
12 - 15 mm	8943.915
15 - 20 mm	8945.915

Needle-tipped grasper

with jaw to carry suture, Ø 2 mm, WL 160 mm, with rinsing port	8756.201
--	----------

Der joystickartige Dichtkonus findet seinen Weg durch die einzelnen Schichten und verschließt die Inzision um das Pneumoperitoneum wieder herzustellen. Dadurch entsteht ein Sicherheitsabstand zwischen der Bauchdecke und den Organen. Die Markierung am Konus signalisiert dabei die ideale Position für die Ligatur.

Mit der Nadelzange wird der Faden durch die Bohrung des Dichtkonus eingebracht und im Bauchraum deponiert. Nach Zurückziehen der Nadelzange und Drehen des Konus um 180° wird die Zange wieder eingeführt, der Faden gegriffen und der Knoten unter endoskopischer Kontrolle extrakorporal durchgeführt.

Die Nadelzange ist ausserdem sehr gut als Notfallnadel zur Unterbindung von Bauchdeckenblutungen geeignet.

Dichtkonus

10 - 12 mm	8934.915
12 - 15 mm	8943.915
15 - 20 mm	8945.915

Nadelzange

mit aktiver Fadenhaltevorrichtung Ø 2 mm, NL 160 mm, mit Spülanschluss	8756.201
--	----------

Cannulas 2 mm / 3 mm
with Luer connector



Kanülen 2 mm / 3 mm
mit Luer-Anschluss



	∅	NL / WL 240 mm	Typen / Types
<i>Injektions- und Aspirationskanüle</i> <i>Injection and aspiration cannula</i>	1.4 / 2.0 mm	240 mm	8309.241
 <i>Injektions- und Aspirationskanüle</i> <i>Injection and aspiration cannula</i>	3.0 mm	310 mm	8379.732

Cannulas 5 mm
with Luer connector

Kanülen 5 mm
mit Luer-Anschluss



		8383.65		8384.60	
		Ø mm Spitze / Tip	NL / WL 345 mm	NL / WL 415 mm	Typen / Types
	Injektions- und Punktionskanüle mit Luer-Anschluss 3 mm <i>Injection and puncture cannula</i> with 3 mm Luer connector	0.7 (22 G)		●	8384.60
	Injektionskanüle mit Luer-Anschluss 3 mm <i>Injection cannula</i> with 3 mm Luer connector	1.8 (15 G)	●		8383.65
	hierzu: Einführungshülse also: <i>Insertion sleeve</i>	(Diese Hülse verhindert eine Beschädigung der Kanülenspitze beim Öffnen des Trokarhülsevenentials.) (This sleeve prevents the tip of the cannula being damaged when opening the valve of the trocar sleeve.)			8383.00

Cannulas 5 mm

with suction control and Luer connector



Kanülen 5 mm

mit Sogsteuerung und Luer-Anschluss

		
	NL / WL 315 mm	Typen / Types
 Punktionskanüle mit Sogsteuerung und 4 mm- Luer-Anschluss Puncture cannula with suction control and 4 mm Luer connector	●	8383.49
 hierzu: Einführungshülse also: Insertion sleeve	(Diese Hülse verhindert eine Beschädigung der Kanülenspitze beim Öffnen des Trokarhülseventils.) (This sleeve prevents the tip of the cannula being damaged when opening the valve of the trocar sleeve.)	8383.00



Probe 3.5 mm



Taststab 3,5 mm

			
	∅	NL / WL	Type / Type
 Taststab, graduiert Probe, graduated	3.5 mm	350 mm	8379.672

Probes / Manipulator
5 mm

Taststäbe / Manipulator
5 mm

			
	NL / WL 330 mm	NL / WL 445 mm	Typen / Types
 Taststab , graduiert, zur Palpation und Größenmessung Probe , graduated, for palpation and measurement	●		8383.66
		●	8384.66

		
	GL / TL 450 mm	Type / Type
 Manipulator mit kugelförmigen Spitzen , beidseitig nutzbar, Ø 4 mm / Ø 5 mm Manipulator with spherical tips , usable at both ends, Ø 4 mm / Ø 5 mm	●	838369

Myoma Screw 5 mm / 10 mm

Myombohrer 5 mm / 10 mm



	Ø	NL / WL	Type / Type
	5 mm	340 mm	8383.611
Myombohrer, starr <i>Myoma screw, rigid</i>	10 mm	340 mm	8385.301

Instrument Set for Bariatric Surgery

Adipositas-Instrumenten-Set

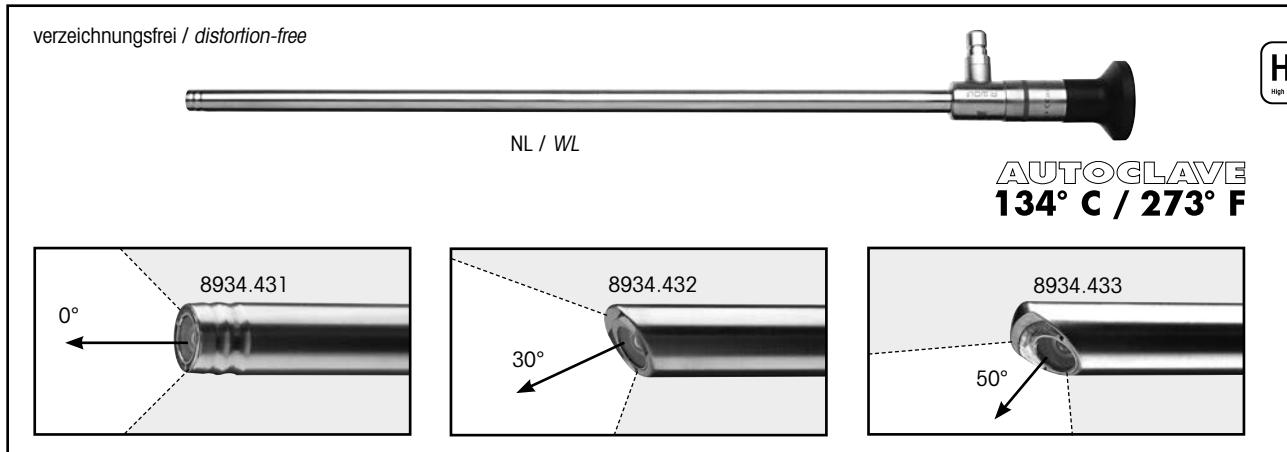

PANOVIEW

- telescope 0° Ø 10mm WL 307mm** 8934.431
- telescope 30° Ø 10mm WL 307mm** 8934.432
- telescope 50° Ø 10mm WL 310mm** 8934.433

PANOVIEW

- Optik 0° Ø 10mm NL 307mm** 8934.431
- Optik 30° Ø 10mm NL 307mm** 8934.432
- Optik 50° Ø 10mm NL 310mm** 8934.433

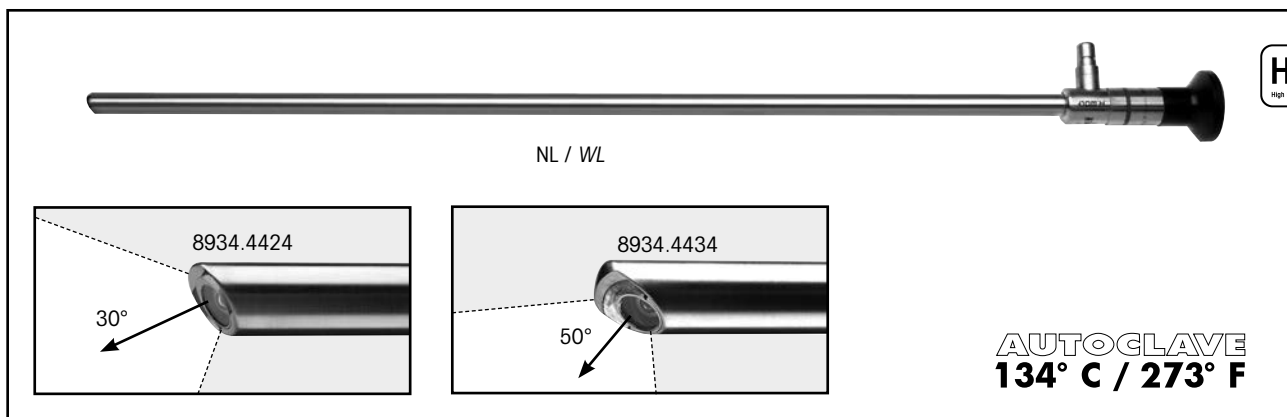

PANOVIEW PLUS

- telescope 25° Ø 10 mm WL 438mm** 8934.4424
- telescope 50° Ø 10 mm WL 447mm** 8934.4434

PANOVIEW PLUS

- Optik 25° Ø 10mm NL 438mm** 8934.4424
- Optik 50° Ø 10mm NL 447mm** 8934.4434

Recommended light cable:

Fiber light cable bundle, Ø 5.0 mm, 2.3 m long consisting of:
 Fiber light cable (80665023), adapter projector side (8095.07) and
 adapter endoscope side (809509)..... 806650231
 (for maximum light transmission)

Fiber light cable bundle *Fusion*, high-temperature resistant,
 Ø 5.0 mm, 2.3 m long consisting of:
 Fiber light cable (80655023), adapter projector side (8095.07) and
 adapter endoscope side (809509)..... 806550231
 (for maximum light transmission)

Accessories:

Perf. basket for standard telescope 3 (for 8934.4424 / .4434)
 (L x W x H) 619 x 59 x 54 mm 38017

Empfohlene Lichtleitkabel:

Fiber Lichtleiter komplett, Ø 5,0 mm, 2,3 m lang bestehend aus:
 Fiber Lichtleiter (80665023), Adapter projektorseitig (8095.07) und
 Adapter endoskopseitig (809509)..... 806650231
 (für maximale Lichttransmission)

Fiber Lichtleiter komplett *Fusion*, hochtemperaturbeständig,
 Ø 5,0 mm, 2,3 m lang bestehend aus:
 Fiber Lichtleiter (80655023), Adapter projektorseitig (8095.07) und
 Adapter endoskopseitig (809509)..... 806550231
 (für maximale Lichttransmission)

Zubehör:

Siebkorb für Standardoptik 3 (für 8934.4424 / .4434)
 (L x B x H) 619 x 59 x 54 mm 38017

Instrument Set for Bariatric Surgery

Adipositas-Instrumenten-Set

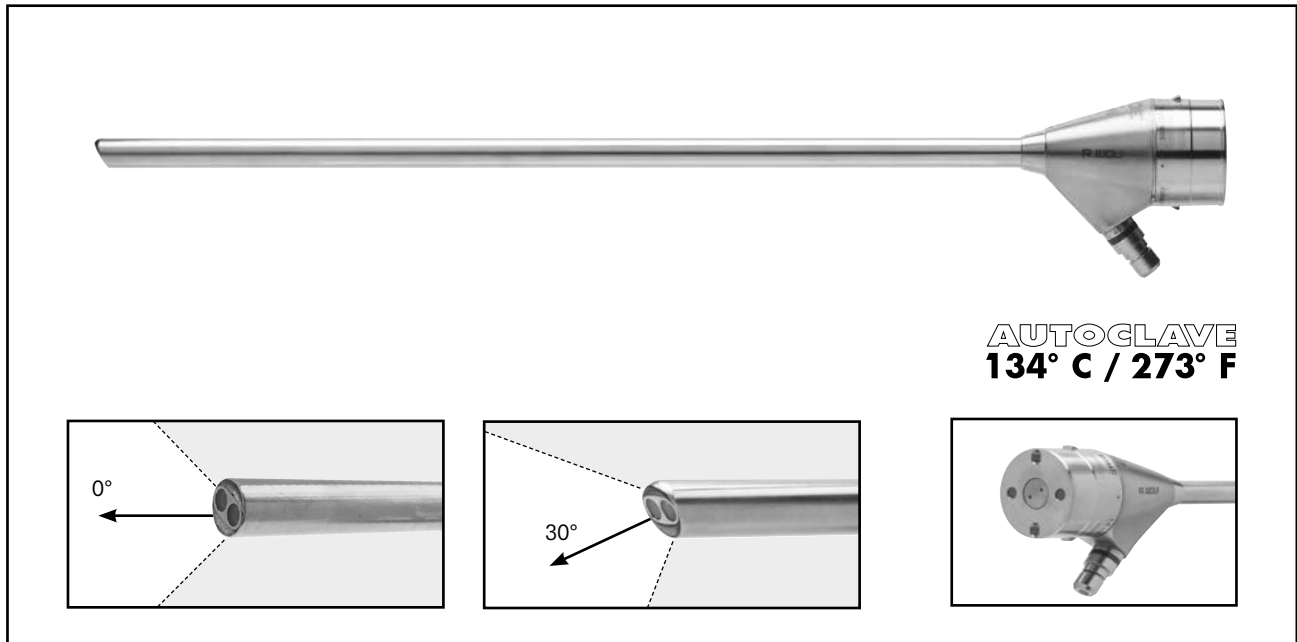

3D endoscope bundle, Ø 10 mm, 0° Set, distortion-free,
consisting of:

3DHD telescope (8934631), 300 mm WL
and perforated basket (38014) 89346311
3DHD telescope (89344631), 430 mm WL
and perforated basket (38014) 893446311

3D endoscope bundle, Ø 10 mm, 30° Set, distortion-free,
consisting of:

3DHD endoscope (8934632), 300 mm WL
and perforated basket (38014) 89346321
3DHD telescope (89344632), 430 mm WL
and perforated basket (38014) 893446321

recommended light cable:

Fiber light cable bundle *Fusion*, high-temperature resistant,
Ø 5.0 mm, 2.3 m long consisting of:

Fiber light cable (80655023), adapter projector-side (8095.07) and
adapter endoscope-side (809509)..... 806550231
(for maximum light transmission)

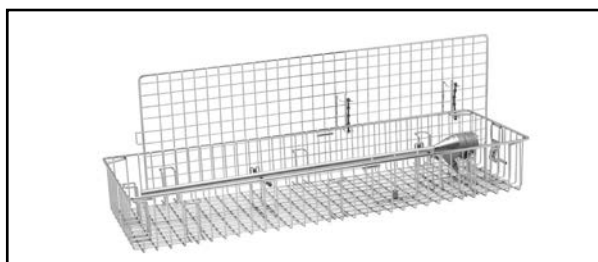

3D Endoskop komplett, Ø 10 mm, 0° Set, verzeichnungsfrei,
bestehend aus:

3DHD Optik (8934631), 300 mm NL
und Siebkorb (38014) 89346311
3DHD Opik (89344631), 430 mm NL
und Siebkorb (38014) 893446311

3D Endoskop komplett, Ø 10 mm, 30° Set, verzeichnungsfrei,
bestehend aus:

3D Endoskop (8934632), 300 mm NL
und Siebkorb (38014) 89346321
3DHD Endoskop (89344632), 430 mm NL
und Siebkorb (38014) 893446321

Empfohlene Lichtleiter:

Fiber Lichtleiter komplett *Fusion*, hochtemperaturbeständig,
Ø 5,0 mm, 2,3 m lang bestehend aus:

Fiber Lichtleiter (80655023), Adapter projektorseitig (8095.07) und
Adapter endoskopseitig (809509)..... 806550231
(für maximale Lichttransmission)

Siebkorb für 3D-Optik







(L x B x H): 583 x 200 x 80 mm 38014

Perforated basket for 3D telescope



(L x W x H): 583 x 200 x 80 mm 38014

Instrument Set for Bariatric Surgery

Adipositas-Instrumenten-Set

RIWO-ART-Trokarhülsen mit Magnet-Kugel-Ventil				Trokar, Spitze kegelig-spitz	Trokar, Spitze dreikantig
					
<i>RIWO-ART trocar sleeves with magnetic-ball-valve</i>	NL / WL	Durchlass / Capacity	Typen / Types	<i>Trocar, conical tip</i>	<i>Trocar, pyramidal tip</i>
Metallrohr mit Gewinde, distal gerade 	100 mm	5.5 mm	8921.024	8921.113	8921.123
<i>Metal with retaining thread, straight distal tip</i>	150 mm	5.5 mm	8921.026	8921.115	8921.125
Metallrohr mit Gewinde, distal gerade 	100 mm	10 mm	8923.024	8923.113	8923.123
<i>Metal with retaining thread, straight distal tip</i>	150 mm	10 mm	8923.026	8923.115	8923.125
Metallrohr, glatt, distal gerade 	100 mm	12,5 mm	8924.014	8924.113	8924.123
<i>Metal sleeve, standard, straight distal tip</i>	150 mm	12,5 mm	8924.016	8924.115	8924.125
Metallrohr mit Gewinde, distal gerade 	150 mm	12,5 mm	8924.026	8924.115	8924.125
<i>Metal with retaining thread, straight distal tip</i>					





13







TROTEC-Trokar bestehend aus: <i>TROTEC trocar consisting of:</i>		TROTEC-Trokar komplett <i>TROTEC trocar complete</i>	Für RIWO ART-Trokarhülse mit: <i>For RIWO ART trocar sleeves:</i>	
 Schaft mit Lanzettenspitze, zweikantig / <i>Sheath with two-edged lance tip</i>	 Griff mit federndem Schutzstab / <i>Handle with spring-mounted protective rod</i>			Nutzlänge <i>Working length</i>
8923.134	8923.135	8923.133	100 mm	10.0 mm
8924.134	8923.135	8924.133	100 mm	12.5 mm

- | | |
|---|---|
| Spare ball, 1 piece, capacity 5.5 mm..... 8921.901 | Ersatzkugel, 1 Stück, Durchlass 5,5 mm..... 8921.901 |
| Spare ball, 1 piece, capacity 10 mm..... 8923.901 | Ersatzkugel, 1 Stück, Durchlass 10 mm..... 8923.901 |
| Spare o-rings, PACK=10 PCS, capacity 5.5 mm 8921.951 | Ersatz-O-Ringe, VE=10 ST, Durchlass 5,5 mm 8921.951 |
| Spare o-rings, PACK=10 PCS, capacity 10 mm 8923.951 | Ersatz-O-Ringe, VE=10 ST, Durchlass 10 mm 8923.951 |
| Spare sealing caps, PACK=10 PCS, capacity 5.5 mm, blue..... 89.02 | Ersatz-Dichtungskappen, VE=10 ST, Durchlass 5,5 mm, blau 89.02 |
| Spare sealing caps, PACK=10 PCS, capacity 10 mm, red 89.08 | Ersatz-Dichtungskappen, VE=10 ST, Durchlass 10 mm, rot..... 89.08 |
| Spare plug, PACK= 5 896.0002 | Ersatz-Hahnküken, VE=5 ST 896.0002 |

Instrument Set for Bariatric Surgery
modular instruments 5 mm

Adipositas-Instrumenten-Set
modulare Instrumente 5 mm

 Alle Innenteile und Schaffrohre sind ebenfalls mit ERAGONaxial kombinierbar. <i>All jaw inserts and sheaths can also be combined with ERAGONaxial.</i>	Griffvarianten / Handle type		Drehradaufsatz, ERAGONaxial Knob attachment, ERAGONaxial  autoklavierbar / autoclavable
	 HF / mono ohne Sperre, drehbar <i>without locking mechanism, rotatable</i>	 HF / mono mit Sperre, drehbar <i>with locking mechanism, rotatable</i>	
Typen / Types	83930083	83930084	8988

Innenteil <i>Jaw insert</i>   MTL / JL*	Schaffrohr, isoliert <i>Sheath tube, insulated</i>		Griffvarianten / Handle type		Komplett-Instrument • Innenteil • Schaffrohr • Handgriff Complete instrument • Jaw insert • Sheath • Handle
		NL / WL 330 mm	NL / WL 450 mm	HF / mono 	
Typen / Types	8393933	8394933	83930074		Typen / Types
 Greif- und Dissektionszange "Maryland Dissektor" gebogen, mit feiner Verzahnung, doppelbeweglich, MTL= 21 mm Grasping and dissecting forceps "Maryland Dissector" curved, with fine cross-cut toothing, double jaw action JL= 21 mm	8393.281	●		●	83932817
	8394.281		●	●	83942817
 Greif- und Dissektionszange gebogen, doppelbeweglich, MTL= 19 mm Grasping and dissecting forceps curved, double jaw action JL= 19 mm	8393240	●		●	83932407
	8394240		●	●	83942407
 Greif- und Dissektionszange , gefensternt mit feiner Querverzahnung, einseitig beweglich, MTL= 26 mm Grasping and dissecting forceps , perforated, fine horizontal serrations, single jaw action, JL= 26 mm	8393.184	●		●	83931847
	8394.184		●	●	83941847

* JL = Jaw length when jaws closed (approximate measurements)



* MTL = Maulteillänge bei geschlossenem Maulteil (gerundete Angaben)









HF connecting cable see page BDE 163.

HF-Anschlusskabel siehe Blatt BDE 163.

Instrument Set for Bariatric Surgery
modular instruments 5 mm

Adipositas-Instrumenten-Set
modulare Instrumente 5 mm

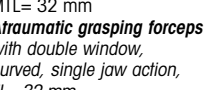
 Alle Innenteile und Schaffrohre sind ebenfalls mit ERAGONaxial kombinierbar. <i>All jaw inserts and sheaths can also be combined with ERAGONaxial.</i>	Griffvarianten / <i>Handle type</i>  mit Sperre, drehbar <i>with locking mechanism, rotatable</i>		Drehradaufsatz, ERAGONaxial <i>Knob attachment, ERAGONaxial</i>  autoklavierbar / <i>autoclavable</i>
	Typen / <i>Types</i>	83930082	8988

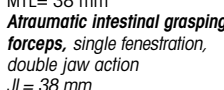
Innenteil <i>Jaw insert</i>  MTL / <i>JL*</i>	Schaffrohr, isoliert <i>Sheath tube, insulated</i>  NL / WL 330 mm NL / WL 450 mm		Griffvarianten / <i>Handle type</i>  mit Sperre, drehbar <i>with locking mechanism, rotatable</i>	Komplett-Instrument • Innenteil • Schaffrohr • Handgriff Complete instrument • <i>Jaw insert</i> • <i>Sheath</i> • <i>Handle</i>
	Typen / <i>Types</i>	8393933 8394933	83930072	
 Greifzange atraumatisch, gefenestert, feine Querverzahnung, doppelbeweglich, MTL= 25 mm Grasping forceps atraumatic, fenestrated, fine cross toothing double jaw action, JL= 25 mm	8393250	●	●	83932507
 Greifzange atraumatisch, gefenestert, feine Querverzahnung, doppelbeweglich, MTL= 25 mm Grasping forceps atraumatic, fenestrated, fine cross toothing double jaw action, JL= 25 mm	8394250	●	●	83942507
 Atraumatische Greifzange doppelt gefenestert, gebogen, einfach beweglich, MTL= 32 mm Atraumatic grasping forceps with double window, curved, single jaw action, JL= 32 mm	8393229	●	●	83932297
 Atraumatische Greifzange doppelt gefenestert, gebogen, einfach beweglich, MTL= 32 mm Atraumatic grasping forceps with double window, curved, single jaw action, JL= 32 mm	8394229	●	●	83942297
 Atraumatische Darmfasszange einfach gefenestert, doppelbeweglich, MTL= 38 mm Atraumatic intestinal grasping forceps single fenestration, double jaw action, JL= 38 mm	8393249	●	●	83932497
 Atraumatische Darmfasszange einfach gefenestert, doppelbeweglich, MTL= 38 mm Atraumatic intestinal grasping forceps single fenestration, double jaw action, JL= 38 mm	8394249	●	●	83942497











* JL = Jaw length when jaws closed (approximate measurements)

* MTL = Maulteillänge bei geschlossenem Maulteil (gerundete Angaben)

Instrument Set for Bariatric Surgery
modular instruments 5 mm

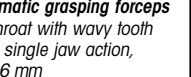
Adipositas-Instrumenten-Set
modulare Instrumente 5 mm

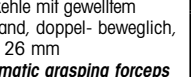
 Alle Innenteile und Schaftröhre sind ebenfalls mit ERAGONaxial kombinierbar. <i>All jaw inserts and sheaths can also be combined with ERAGONaxial.</i>	Griffvarianten / Handle type		Drehradanschluss, ERAGONaxial Knob attachment, ERAGONaxial  autoklavierbar / autoclavable
	 mit Sperre, drehbar <i>with locking mechanism, rotatable</i>	 HF / mono mit Sperre, drehbar <i>with locking mechanism, rotatable</i>	
Typen / Types	83930082	83930084	8988

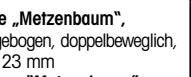
Innenteil <i>Jaw insert</i>   MTL / JL*	Schaftröhre, isoliert <i>Sheath tube, insulated</i>		Griffvarianten / Handle type		Komplett-Instrument • Innenteil • Schaftröhre • Handgriff Complete instrument • Jaw insert • Sheath • Handle
	 NL / WL 330 mm	NL / WL 450 mm	 mit Sperre, drehbar <i>with locking mechanism, rotatable</i>	 HF mono ohne Sperre, drehbar <i>without locking mechanism, rotatable</i>	
Typen / Types	8393933	8394933	83930072	83930073	Typen / Types
 Atraumatische Greifzange Maulkehle mit gewelltem Zahnrand, einfach beweglich, MTL= 26 mm <i>Atraumatic grasping forceps jaw throat with wavy tooth edge, single jaw action, JL= 26 mm</i>	8393.292	●	●	●	83932925
 Atraumatische Greifzange Maulkehle mit gewelltem Zahnrand, doppel- beweglich, MTL= 26 mm <i>Atraumatic grasping forceps jaw throat with wavy tooth edge, double jaw action, JL= 26 mm</i>	8394.292	●	●	●	83942925
 Atraumatische Greifzange Maulkehle mit gewelltem Zahnrand, doppel- beweglich, MTL= 26 mm <i>Atraumatic grasping forceps jaw throat with wavy tooth edge, double jaw action, JL= 26 mm</i>	8393.293	●	●	●	83932935
 Atraumatische Greifzange Maulkehle mit gewelltem Zahnrand, doppel- beweglich, MTL= 26 mm <i>Atraumatic grasping forceps jaw throat with wavy tooth edge, double jaw action, JL= 26 mm</i>	8394.293	●	●	●	83942935
 Schere „Metzenbaum“ , links gebogen, doppelbeweglich, MTL= 23 mm <i>Scissors "Metzenbaum" curved left, double jaw action, JL= 23 mm</i>	8393.041	●	●	●	83930417
 Schere „Metzenbaum“ , links gebogen, doppelbeweglich, MTL= 23 mm <i>Scissors "Metzenbaum" curved left, double jaw action, JL= 23 mm</i>	8394.041	●	●	●	83940417

* JL = Jaw length when jaws closed (approximate measurements)

* MTL = Maulteillänge bei geschlossenem Maulteil (gerundete Angaben)

HF connecting cable see page BDE 163.

HF-Anschlusskabel siehe Blatt BDE 163.

Instrument Set for Bariatric Surgery

ERAGON modular sheath tube with cm scale

Adipositas-Instrumenten-Set



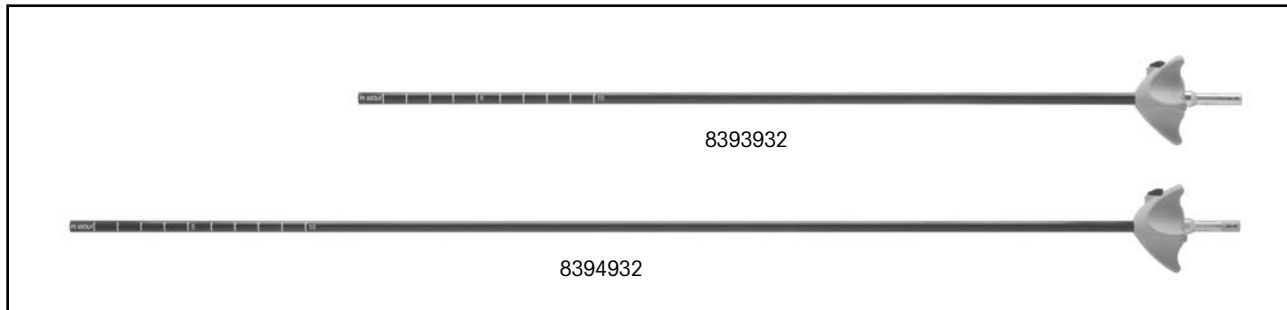

ERAGON modular Schaffrohr mit cm-Markierung





	∅	NL / WL	Typen / Types
 <p>ERAGON modular Schaffrohr, monopolar, mit distaler cm-Markierung ERAGON modular sheath tube, monopolar, with distal cm scale</p>	5 mm	330 mm	8393932
		450 mm	8394932

Instrument Set for Bariatric Surgery
Gastric Band Manipulator 5 mm

Adipositas-Instrumenten-Set
Gastric Band Manipulator 5 mm

 <p>Alle Innenteile und Schaffrohre sind ebenfalls mit ERAGONaxial kombinierbar. <i>All jaw inserts and sheaths can also be combined with ERAGONaxial.</i></p>	Griffvarianten / Handle type		<p>Drehradaufsatz, ERAGONaxial <i>Knob attachment, ERAGONaxial</i></p>  <p>autoklavierbar / autoclavable</p>
	 mit Sperre, drehbar <i>with locking mechanism, rotatable</i>	 mit Sperre, nicht drehbar <i>with locking mechanism, not rotatable</i>	
Typen / Types	83930082	83930085	8988





<p>Innenteil / Jaw insert</p>  <p>MTL / JL*</p>	Schaffrohr, isoliert <i>Sheath tube, insulated</i>		<p>Griffvarianten / Handle type</p>  mit Sperre, drehbar <i>with locking mechanism, rotatable</i>	<p>Komplett-Instrument</p> <ul style="list-style-type: none"> • Innenteil • Schaffrohr • Handgriff <p>Complete instrument</p> <ul style="list-style-type: none"> • Jaw insert • Sheath tube • Handle
	 NL / WL 330 mm NL / WL 450 mm	83930072		
Typen / Types	8393933	8394933	83930072	Typen / Types
8393253	●		●	83932537
8394253		●	●	83942537
<p>Gastric Band Manipulator, MTL= 45 mm <i>Gastric band manipulator, JL= 45 mm</i></p>				







* JL = Jaw length when jaws closed (approximate measurements)

* MTL = Maulteillänge bei geschlossenem Maulteil (gerundete Angaben)

Instrument Set for Bariatric Surgery
modular Instruments 10 mm

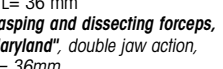
Adipositas-Instrumenten-Set
modulare Instrumente 10 mm

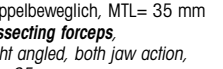
 <p>Alle Innenteile und Schaffrohre sind ebenfalls mit ERAGONaxial kombinierbar. <i>All jaw inserts and sheaths can also be combined with ERAGONaxial.</i></p>	Griffvarianten / Handle type		<p>Drehradaufsatz, ERAGONaxial <i>Knob attachment, ERAGONaxial</i></p>  <p>autoklavierbar / autoclavable</p>
	 <p>mit Sperre, drehbar <i>with locking mechanism, rotatable</i></p>	 <p>mit Sperre, nicht drehbar <i>with locking mechanism, not rotatable</i></p>	
Typen / Types	83930082	83930085	8988

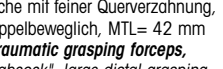



<p>Innenteil / Jaw insert</p>   <p>MTL / JL*</p>	Schaffrohr, unisoliert <i>Sheath tube, uninsulated</i>		Griffvarianten / Handle type		<p>Komplett-Instrument</p> <ul style="list-style-type: none"> • Innenteil • Schaffrohr • Handgriff <p>Complete instrument</p> <ul style="list-style-type: none"> • Jaw insert • Sheath tube • Handle
	Typen / Types	NL / WL 330 mm	NL / WL 450 mm	mit Sperre, ohne HF-Anschluss <i>with locking mechanism, without HF connector</i>	
 <p>8395.225</p> <p>Greif- / Dissektionszange "Maryland", doppelbeweglich MTL= 36 mm <i>Grasping and dissecting forceps, "Maryland", double jaw action, JL= 36mm</i></p>	●		●		83952257
 <p>8396225</p> <p>Greif- / Dissektionszange "Maryland", doppelbeweglich MTL= 36 mm <i>Grasping and dissecting forceps, "Maryland", double jaw action, JL= 36mm</i></p>		●	●		83962257
 <p>8395.226</p> <p>Dissektionszange, rechtwinkelig gebogen, doppelbeweglich, MTL= 35 mm <i>Dissecting forceps, right angled, both jaw action, JL= 35 mm</i></p>	●		●		83952268
 <p>8396226</p> <p>Dissektionszange, rechtwinkelig gebogen, doppelbeweglich, MTL= 35 mm <i>Dissecting forceps, right angled, both jaw action, JL= 35 mm</i></p>		●	●		83962267
 <p>8395.187</p> <p>Atraumatische Greifzange "Babcock", große distale Greiffläche mit feiner Querverzahnung, doppelbeweglich, MTL= 42 mm <i>Atraumatic grasping forceps, "Babcock", large distal grasping surface with fine horizontal serration, double jaw action, JL= 42 mm</i></p>	●		●		83951877
 <p>8396187</p> <p>Atraumatische Greifzange "Babcock", große distale Greiffläche mit feiner Querverzahnung, doppelbeweglich, MTL= 42 mm <i>Atraumatic grasping forceps, "Babcock", large distal grasping surface with fine horizontal serration, double jaw action, JL= 42 mm</i></p>		●	●		83961877

* JL = Jaw length when jaws closed (approximate measurements)

* MTL = Maulteillänge bei geschlossenem Maulteil (gerundete Angaben)

Instrument Set for Bariatric Surgery
modular Instruments 10 mm

Adipositas-Instrumenten-Set
modulare Instrumente 10 mm

Innenteil / <i>Jaw insert</i>  ERAGON modular	Schaftrohr, unisoliert <i>Sheath tube, uninsulated</i>  NL / WL 380 mm	Griffvarianten / <i>Handle type</i> 		Komplett-Instrument • Innenteil • Schaftrohr • Handgriff Complete instrument • <i>Jaw insert</i> • <i>Sheath tube</i> • <i>Handle</i>	
	Typen / Types	8397902	83930072	83930082	Typen / Types
 Manipulator für Gastric Banding 90° abwinkelbarer, atraumatischer Dissektor, Branche mit distalem Langloch und Haken Manipulator for Gastric Banding 90° articulable, atraumatic dissector, branch with distal slot and hook	8397.654	●	●		83976547
 Stapler-Kopf-Greifzange 30° abgewinkelt, doppelbeweglich Stapler-head-grasping forceps 30° angled, double-action	8397.655	●		●	83976558

* JL = *Jaw length when jaws closed (approximate measurements)*



* MTL = *Maulteillänge bei geschlossenem Maulteil (gerundete Angaben)*

Instrument Set for Bariatric Surgery

Electrode, monopolar, 5 mm

Adipositas-Instrumenten-Set

Elektrode, monopolar, 5 mm







		
	NL / WL	Typen / Type
 Haken-Elektrode <i>Hook electrode</i>	420 mm	8384.423

Instrument Set for Bariatric Surgery

Needle Holder 5 mm
modular system

Adipositas-Instrumenten-Set

Nadelhalter 5 mm
modulares System

<p>Innenteil mit Schaffrohr und Spülanschluss Inner section with sheath tube and irrigation tap</p> 		<p>Axialer Handgriff / Axial handle</p>  <ul style="list-style-type: none"> • einseitig beweglich • ausschaltbare Rastsicherung • one jaw opening • locking mechanism can be disabled 		<p>Komplett-Instrument</p> <ul style="list-style-type: none"> • Innenteil mit Schaffrohr • Griff <p>Complete instrument</p> <ul style="list-style-type: none"> • Inner section with sheath tube • Handle 		
		Typen / Types	Ø	NL / WL	8393.941	Typen / Types
 <p>Modularer Nadelhalter, gerade mit Hartmetalleinsatz Modular needle holder, straight with carbide insert</p>	8393.505	5 mm	310 mm	●	8393.502	
	8394.505	5 mm	430 mm	●	8394.502	
 <p>Modularer Nadelhalter, rechts gebogen mit Hartmetalleinsatz Modular needle holder, curved right with carbide insert</p>	8393.514	5 mm	310 mm	●	8393.511	
	8394.514	5 mm	430 mm	●	8394.511	
 <p>Modularer Nadelhalter, links gebogen mit Hartmetalleinsatz Modular needle holder, curved left with carbide insert</p>	8393.515	5 mm	310 mm	●	8393.512	
	8394.515	5 mm	430 mm	●	8394.512	
 <p>Modularer Multifunktions*-Nadelhalter nach Sarbu Modular multifunction* needle holder by Sarbu</p>	8393.506	5 mm	310 mm	●	8393.503	
	8394.506	5 mm	430 mm	●	8394.503	

* with automatic needle alignment mechanism and cutting edge







* mit automatischer Nadelaufstellvorrichtung und Schneidkante





Instrument Set for Bariatric Surge

ERAGON modular Knot Pusher 5 mm

Adipositas-Instrumenten-Set

ERAGON modular Knotenschieber 5 mm

 <p>Alle Maulteile und Schaffrohre sind ebenfalls mit ERAGONaxial kombinierbar. All jaw inserts and sheaths can also be combined with ERAGONaxial.</p>	Griffvarianten / Handle type				<p>Drehradaufsatz, ERAGONaxial Knob attachment, ERAGONaxial</p>  <p>autoklavierbar / autoclavable</p>
	 <p>mit Sperre, drehbar with locking mechanism, rotatable</p>	 <p>HF / mono ohne Sperre, drehbar without locking mechanism, rotatable</p>	 <p>HF / mono mit Sperre, drehbar with locking mechanism, rotatable</p>	 <p>mit Sperre, nicht drehbar with locking mechanism, not rotatable</p>	
Typen / Types	83930082	83930083	83930084	83930085	8988

<p>Innenteil / Jaw insert</p>  <p>MTL / JL*</p>	<p>Schaffrohr, isoliert Sheath tube, insulated</p> 		<p>Griffvarianten / Handle type</p> 	<p>Komplett-Instrument</p> <ul style="list-style-type: none"> • Innenteil • Schaffrohr • Handgriff <p>Complete instrument</p> <ul style="list-style-type: none"> • Jaw insert • Sheath tube • Handle
	<p>NL / WL 330 mm</p>	<p>NL / WL 450 mm</p>	<p>mit Sperre, drehbar with locking mechanism, rotatable</p>	
Typen / Types	8393933	8394933	83930072	Typen / Types
	8393.345	●	●	83933457
<p>Extrakorporaler Knotenschieber, mit distaler Aussparung, doppelbeweglich, MTL= 17 mm Extracorporeal knot pusher, with distal fork, double jaw action, MTL= 17 mm</p>	8394345	●	●	83943457

* JL = Jaw length when jaws closed (approximate measurements)

* MTL = Maulteillänge bei geschlossenem Maulteil (gerundete Angaben)

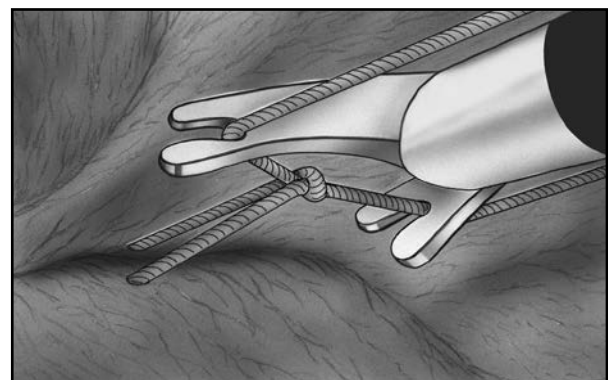

Extrakorporale Knotentechnik
Extracorporeal knotting technique

INSUFFLATOR Highflow 45 BASIC

INSUFFLATOR Highflow 45 BASIC



- 6.5" Color display
- Touchscreen
- Max. flow rate 45 l / min
- Functional and user-friendly design
- Optional configurable software modules

- 6,5" Farbdisplay
- Touchscreen
- Max. Flowrate 45 l / min
- Funktionelles und anwenderfreundliches Design
- Optional konfigurierbare Software-Module

INSUFFLATOR Highflow 45 BASIC Set

consisting of:

INSUFFLATOR Highflow 45 Basic (2235001),
insufflation tube, Ø 5 mm, 2.5 m long (8170.101),
hygiene filter, sterile PACK=10 PCS (4171.111),
power cable 3 m long (2440.03) 22350011

INSUFFLATOR Highflow 45 BASIC Set

bestehend aus:

INSUFFLATOR Highflow 45 Basic (2235001),
Insufflationsschlauch, Ø 5 mm, 2,5 m lang (8170.101),
Hygiene-Filter, VE=10 ST, steril verpackt (4171.111),
Netzkabel 3 m lang (2440.03) 22350011

Necessary accessories:

Connecting hose CO₂ 1,5m NIST-NIST 74021038
with

Pressure reducer CO₂

DIN 477-1 74007.054
DIN EN ISO 407 74007.055
ISO 5145 74007.056

or

Connecting hose CO₂ 5,0m DIN

for central CO₂ gas supply (Air Liquide) 74021039

Connecting hose CO₂ 5,0m NF

for central CO₂ gas supply (Air Liquide) 74021040

Erforderliches Zubehör:

Verbindungsschlauch CO₂ 1,5m NIST-NIST 74021038
mit

Druckminderer CO₂

DIN 477-1 74007.054
DIN EN ISO 407 74007.055
ISO 5145 74007.056

oder

Verbindungsschlauch CO₂ 5,0m DIN

für zentrale CO₂-Gasversorgung (Dräger) 74021039

Verbindungsschlauch CO₂ 5,0m NF

für zentrale CO₂-Gasversorgung (Air Liquide) 74021040

Optional accessories:

Insufflation tube, disposable

with integrated hygiene filter,

PACK=10 PCS, in individual sterile packs 4170.501

High-flow insufflation tube*,

Ø 8 mm, autoclavable 8170.232

*recommended in conjunction with high-flow trocar sleeves

Optionales Zubehör:

Insufflationsschlauch, zum Einmalgebrauch

mit integriertem Hygienefilter,

VE=10 ST, einzeln steril verpackt 4170.501

High-Flow-Insufflationsschlauch*,

Ø 8 mm, autoklavierbar 8170.232

*in Verbindung mit High-Flow-Trokarhülsen empfohlen

Optional software module:

Software module CAN-BUS, integrated core 2235101

Software module BABY-MODE 2235102

Software module VIDEO-DISPLAY 2235103

Optionale Software-Module:

Softwaremodul CAN-BUS, Integration in core 2235101

Softwaremodul BABY-MODE 2235102

Softwaremodul VIDEOEINBLENDUNG 2235103

INSUFFLATOR

Highflow 45 BASIC

Technical data

INSUFFLATOR

Highflow 45 BASIC

Technische Daten

Schutzklasse nach IEC / EN 60601-1 ; (UL 60601-1 / CSA C22.2 No.601.1 - für USA) <i>Protection class complying with IEC / EN 60601-1 ; (UL 60601-1 / CSA C22.2 No.601.1 - for USA)</i>	1
Elektromagnetische Verträglichkeit (EMV) <i>Electromagnetic compatibility (EMC)</i>	gemäß IEC / EN 60601-1-2 <i>according to EN 60601-1-2</i>
Richtlinie über Medizinprodukte 93/42/EWG <i>Medical Device Directive 93/42/EEC</i>	Klasse IIb <i>Class IIb</i>
Schutz gegen elektrischen Schlag <i>Protection against electric shock</i>	Anwendungsteil des Typs CF <i>Application part of Type CF</i>
Schutzgrad gegen Eindringen von Flüssigkeit <i>Degree of protection against penetration of liquids</i>	IP 20 (nicht geschützt) <i>IP 20 (not protected)</i>
Betriebsart <i>Duty cycle</i>	Dauerbetrieb <i>Continuous operation</i>
Schutzgrad bei Anwendung in Gegenwart von brennbaren Gemischen <i>Degree of protection when flammable mixtures are present</i>	Gerät ist nicht explosionsgeschützt (Gerät nicht in zündfähiger Atmosphäre betreiben) <i>This device is not protected against explosions (Do not operate this device in areas where explosive substances are present)</i>
Gewicht <i>Weight</i>	8,9 kg (19,5 lbs) <i>8.9 kg (19.5 lbs)</i>
Abmessungen (B x H x T) <i>Dimensions (W x H x D)</i>	300 mm x 160 mm x 455 mm
Spannung <i>Voltage</i>	100 - 240 V~ / a.c.
Frequenz <i>Frequency</i>	50 / 60 Hz
Leistungsaufnahme <i>Power consumption</i>	60 VA
Sicherung <i>Fuse</i>	T 3,15 H <i>T 3.15 H</i>
Stromaufnahme <i>Power rating</i>	0,6 - 0,2 A <i>0.6 - 0.2 A</i>

Relevante Anwendungsparameter / Relevant application parameters:

Insufflationsmedium <i>Insufflation medium</i>	med. CO ₂ (Reinheitsgrad > 99,5 %) <i>med. CO₂ (purity > 99,5 %)</i>
Intraabdominalen Druck <i>Intra-abdominal pressure</i>	3 mmHg bis / to 25 mmHg, (± 2 mmHg) vorwählbar / <i>preselectable</i> in 1 mmHg - Schritten / <i>Steps</i>
Gasflussrate: - Primärfüllung - High Flow <i>Gas flow rate: - primary filling - high flow</i>	1 l/min. (± 50 %) 2 l/min. bis 45 l/min. (± 20 %) vorwählbar in 1 l/min Schritten 1 l/min. 2 l/min. to 45 l/min. (± 20 %) <i>preselectable in 1 l/min steps</i>
Verbrauchsanzeige <i>Consumption display</i>	0 l bis 9999 l (± 20 %) 0 l to 9999 l (± 20 %)

INSUFFLATOR Highflow 45 EVAC

INSUFFLATOR Highflow 45 EVAC



- 6,5" Color display
- Touchscreen
- Max. flow rate 45 l / min
- Functional and user-friendly design
- Optional configurable software modules
- Smoke gas evacuation

- 6,5" Farbdisplay
- Touchscreen
- Max. Flowrate 45 l / min
- Funktionelles und anwenderfreundliches Design
- Optional konfigurierbare Software-Module
- Rauchgasabsaugung

Insufflator Highflow 45 EVAC Set

consisting of:

Insufflator Highflow 45 EVAC (2235011),
insufflation tube, Ø 5 mm, 2.5 m long (8170.101),
hygiene filter, sterile PACK=10 PCS (4171.111),
Insufflation tube, disposable with integrated hygiene filter,
PACK=10 PCS, in individual sterile packs (4170.501)
disposable tube set for smoke gas evacuation, sterile (PACK=10 PCS)
(4170503), one-pedal footswitch (20301031) and
power cable 3 m long (2440.03) 22350111

Necessary accessories:

Connecting hose CO₂ 1,5m NIST-NIST 74021038
with

Pressure reducer CO₂

DIN 477-1 74007.054

DIN EN ISO 407 74007.055

ISO 5145 74007.056

or

Connecting hose CO₂ 5,0m DIN

for central CO₂ gas supply (Air Liquide) 74021039

Connecting hose CO₂ 5,0m NF

for central CO₂ gas supply (Air Liquide) 74021040

Disposable tube set for smoke gas evacuation,

sterile (PACK=10 PCS) 4170503

Optional accessories:

High-flow insufflation tube, Ø 8 mm,

autoclavable 8170.232

Insufflation tube,

disposable with integrated hygiene filter,

PACK=10 PCS, in individual sterile packs 4170501

Optional software module:

Software module CAN-BUS, integrated core 2235101

Software module BABY-MODE 2235102

Software module VIDEO-DISPLAY 2235103

Insufflator Highflow 45 EVAC Set

bestehend aus:

Insufflator Highflow 45 EVAC (2235011),
Insufflationsschlauch, Ø 5 mm, 2,5 m lang (8170.101),
Hygiene-Filter, VE=10 ST, steril verpackt (4171.111),
Insufflationsschlauch, zum Einmalgebrauch mit integriertem
Hygienefilter, VE=10 ST, einzeln steril verpackt (4170.501),
Schlauchset Rauchgasabsaugung steril (4170503),
Einpedal-Fußschalter (20301031) und
Netzkabel 3 m lang (2440.03) 22350111

Erforderliches Zubehör:

Verbindungsschlauch CO₂ 1,5m NIST-NIST 74021038
mit

Druckminderer CO₂

DIN 477-1 74007.054

DIN EN ISO 407 74007.055

ISO 5145 74007.056

oder

Verbindungsschlauch CO₂ 5,0m DIN

für zentrale CO₂-Gasversorgung (Dräger) 74021039

Verbindungsschlauch CO₂ 5,0m NF

für zentrale CO₂-Gasversorgung (Air Liquide) 74021040

Einweg-Schlauchset Rauchgasabsaugung,

steril (VE=10 ST) 4170503

Optionales Zubehör:

High-Flow-Insufflationsschlauch, Ø 8 mm,

autoklavierbar 8170.232

Insufflationsschlauch

zum Einmalgebrauch mit integriertem Hygienefilter,

(VE=10 ST), einzeln steril verpackt 4170501

Optionale Software-Module:

Softwaremodul CAN-BUS, Integration in core 2235101

Softwaremodul BABY-MODE 2235102

Softwaremodul VIDEOEINBLENDUNG 2235103

INSUFFLATOR

Highflow 45 EVAC

Technical data

INSUFFLATOR

Highflow 45 EVAC

Technische Daten

Schutzklasse nach IEC / EN 60601-1 ; (UL 60601-1 / CSA C22.2 No.601.1 - für USA) <i>Protection class complying with IEC / EN 60601-1 ; (UL 60601-1 / CSA C22.2 No.601.1 - for USA)</i>	1
Elektromagnetische Verträglichkeit (EMV) <i>Electromagnetic compatibility (EMC)</i>	gemäß IEC / EN 60601-1-2 <i>according to EN 60601-1-2</i>
Richtlinie über Medizinprodukte 93/42/EWG <i>Medical Device Directive 93/42/EEC</i>	Klasse IIb <i>Class IIb</i>
Schutz gegen elektrischen Schlag <i>Protection against electric shock</i>	Anwendungsteil des Typs CF <i>Application part of Type CF</i>
Schutzgrad gegen Eindringen von Flüssigkeit <i>Degree of protection against penetration of liquids</i>	IP 20 (nicht geschützt) <i>IP 20 (not protected)</i>
Betriebsart <i>Duty cycle</i>	Dauerbetrieb <i>Continuous operation</i>
Schutzgrad bei Anwendung in Gegenwart von brennbaren Gemischen <i>Degree of protection when flammable mixtures are present</i>	Gerät ist nicht explosionsgeschützt (Gerät nicht in zündfähiger Atmosphäre betreiben) <i>This device is not protected against explosions (Do not operate this device in areas where explosive substances are present)</i>
Gewicht <i>Weight</i>	8,9 kg (19,5 lbs) <i>8.9 kg (19.5 lbs)</i>
Abmessungen (B x H x T) <i>Dimensions (W x H x D)</i>	300 mm x 160 mm x 455 mm
Spannung <i>Voltage</i>	100 - 240 V~ / a.c.
Frequenz <i>Frequency</i>	50 / 60 Hz
Leistungsaufnahme <i>Power consumption</i>	60 VA
Sicherung <i>Fuse</i>	T 3,15 H <i>T 3.15 H</i>
Stromaufnahme <i>Power rating</i>	0,6 - 0,2 A <i>0.6 - 0.2 A</i>

Relevante Anwendungsparameter / Relevant application parameters:

Insufflationsmedium <i>Insufflation medium</i>	med. CO ₂ (Reinheitsgrad > 99,5 %) <i>med. CO₂ (purity > 99,5 %)</i>
Intraabdominalen Druck <i>Intra-abdominal pressure</i>	3 mmHg bis / to 25 mmHg, (± 2 mmHg) vorwählbar / <i>preselectable</i> in 1 mmHg - Schritten / <i>Steps</i>
Gasflussrate: - Primärfüllung - High Flow <i>Gas flow rate: - primary filling - high flow</i>	1 l/min. (± 50 %) 2 l/min. bis 45 l/min. (± 20 %) vorwählbar in 1 l/min Schritten <i>1 l/min. 2 l/min. to 45 l/min. (± 20 %) preselectable in 1 l/min steps</i>
Verbrauchsanzeige <i>Consumption display</i>	0 l bis 9999 l (± 20 %) <i>0 l to 9999 l (± 20 %)</i>

INSUFFLATOR Highflow 45 HEAT

INSUFFLATOR Highflow 45 HEAT



- 6.5" Color display
- Touchscreen
- Max. flow rate 45 l / min
- Functional and user-friendly design
- CO₂ gas heating function
- Optional configurable software modules

- 6,5" Farbdisplay
- Touchscreen
- Max. Flowrate 45 l / min
- Funktionelles und anwenderfreundliches Design
- CO₂-Gaserwärmungsfunktion
- Optional konfigurierbare Software-Module

INSUFFLATOR Highflow 45 HEAT Set

consisting of:

INSUFFLATOR Highflow 45 HEAT (2235021),
Insufflation tube, with heating element, High-Flow,
3m long, autoclavable (8170202)
hygiene filter, sterile PACK=10 PCS (4171.111) and
power cable 3 m long (2440.03) 22350211

Necessary accessories:

Connecting hose CO₂ 1,5m NIST-NIST 74021038
with

Pressure reducer CO₂
DIN 477-1 74007.054
DIN EN ISO 407 74007.055
ISO 5145..... 74007.056

or

Connecting hose CO₂ 5,0m DIN
for central CO₂ gas supply (Air Liquide) 74021039

Connecting hose CO₂ 5,0m NF
for central CO₂ gas supply (Air Liquide) 74021040

Optional accessories:

Insufflation tube, disposable
with heating element, High-Flow, with integrated hygiene filter,
PACK=10 PCS, in individual sterile packs 4170502

Optional software module:

Software module CAN-BUS, integrated core 2235101
Software module BABY-MODE 2235102
Software module VIDEO-DISPLAY 2235103

INSUFFLATOR Highflow 45 HEAT Set

bestehend aus:

INSUFFLATOR Highflow 45 HEAT (2235021),
Insufflationsschlauch mit Heizspirale, High-Flow,
3m lang, autoklavierbar (8170202)
Hygiene-Filter, VE=10 ST, steril verpackt (4171.111) und
Netzkabel 3 m lang (2440.03) 22350211

Erforderliches Zubehör:

Verbindungsschlauch CO₂ 1,5m NIST-NIST 74021038
mit

Druckminderer CO₂
DIN 477-1 74007.054
DIN EN ISO 407 74007.055
ISO 5145..... 74007.056

oder

Verbindungsschlauch CO₂ 5,0m DIN
für zentrale CO₂-Gasversorgung (Dräger) 74021039

Verbindungsschlauch CO₂ 5,0m NF
für zentrale CO₂-Gasversorgung (Air Liquide) 74021040

Optionales Zubehör:

Insufflationsschlauch, zum Einmalgebrauch
mit Heizspirale, High-Flow, mit integriertem Hygienefilter,
VE=10 ST, einzeln steril verpackt 4170502

Optionale Software-Module:

Softwaremodul CAN-BUS, Integration in core..... 2235101
Softwaremodul BABY-MODE 2235102
Softwaremodul VIDEOEINBLENDUNG 2235103

INSUFFLATOR

Highflow 45 HEAT

Technical data

INSUFFLATOR

Highflow 45 HEAT

Technische Daten

Schutzklasse nach IEC / EN 60601-1 ; (UL 60601-1 / CSA C22.2 No.601.1 - für USA) <i>Protection class complying with IEC / EN 60601-1 ; (UL 60601-1 / CSA C22.2 No.601.1 - for USA)</i>	1
Elektromagnetische Verträglichkeit (EMV) <i>Electromagnetic compatibility (EMC)</i>	gemäß IEC / EN 60601-1-2 <i>according to EN 60601-1-2</i>
Richtlinie über Medizinprodukte 93/42/EWG <i>Medical Device Directive 93/42/EEC</i>	Klasse IIb <i>Class IIb</i>
Schutz gegen elektrischen Schlag <i>Protection against electric shock</i>	Anwendungsteil des Typs CF <i>Application part of Type CF</i>
Schutzgrad gegen Eindringen von Flüssigkeit <i>Degree of protection against penetration of liquids</i>	IP 20 (nicht geschützt) <i>IP 20 (not protected)</i>
Betriebsart <i>Duty cycle</i>	Dauerbetrieb <i>Continuous operation</i>
Schutzgrad bei Anwendung in Gegenwart von brennbaren Gemischen <i>Degree of protection when flammable mixtures are present</i>	Gerät ist nicht explosionsgeschützt (Gerät nicht in zündfähiger Atmosphäre betreiben) <i>This device is not protected against explosions (Do not operate this device in areas where explosive substances are present)</i>
Gewicht <i>Weight</i>	11,0 kg (23,3 lbs) <i>11.0 kg (23.3 lbs)</i>
Abmessungen (B x H x T) <i>Dimensions (W x H x D)</i>	300 mm x 160 mm x 455 mm
Spannung <i>Voltage</i>	100 - 127 / 220 - 240 V~ / a.c.
Frequenz <i>Frequency</i>	50 / 60 Hz
Leistungsaufnahme <i>Power consumption</i>	80 VA
Sicherung <i>Fuse</i>	T 3,15 H <i>T 3.15 H</i>
Stromaufnahme <i>Power rating</i>	0,8 - 0,3 A <i>0.8 - 0.3 A</i>

Relevante Anwendungsparameter / Relevant application parameters:

Insufflationsmedium <i>Insufflation medium</i>	med. CO ₂ (Reinheitsgrad > 99,5 %) <i>med. CO₂ (purity > 99,5 %)</i>
Intraabdominalen Druck <i>Intra-abdominal pressure</i>	3 mmHg bis / to 25 mmHg, (± 2 mmHg) vorwählbar / <i>preselectable</i> in 1 mmHg - Schritten / <i>Steps</i>
Gasflussrate: - Primärfüllung - High Flow <i>Gas flow rate: - primary filling - high flow</i>	1 l/min. (± 50 %) 2 l/min. bis 45 l/min. (± 20 %) vorwählbar in 1 l/min Schritten 1 l/min. 2 l/min. to 45 l/min. (± 20 %) <i>preselectable in 1 l/min steps</i>
Verbrauchsanzeige <i>Consumption display</i>	0 l bis 9999 l (± 20 %) <i>0 l to 9999 l (± 20 %)</i>
Gastemperatur mit Heizschlauch <i>Gas temperature with airbag</i>	37 °C ± 2°C

INSUFFLATOR Highflow 45 HEAT EVAC + HEAT

INSUFFLATOR Highflow 45 EVAC + HEAT

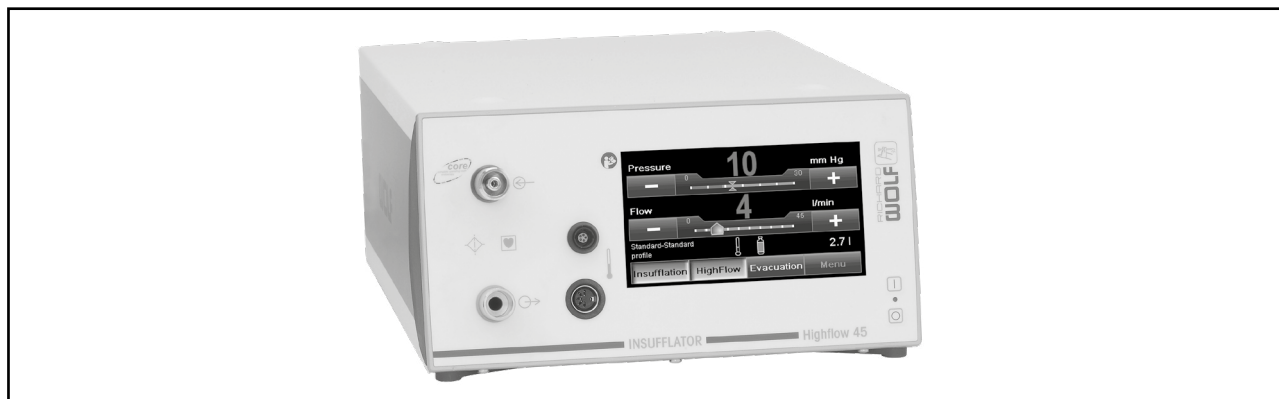

- 6.5" Color display
- Touchscreen
- Max. flow rate 45 l / min
- Functional and user-friendly design
- CO₂ gas heating function
- Optional configurable software modules
- Smoke gas evacuation

- 6,5" Farbdisplay
- Touchscreen
- Max. Flowrate 45 l / min
- Funktionelles und anwenderfreundliches Design
- CO₂-Gaserwärmungsfunktion
- Optional konfigurierbare Software-Module
- Rauchgasabsaugung

INSUFFLATOR Highflow 45 EVAC + HEAT Set

consisting of: INSUFFLATOR Highflow 45 EVAC + HEAT (2235031), Insufflation tube, with heating element, High-Flow, 3m long, autoclavable (8170202), insufflation tube, disposable with heating element, High-Flow, with integrated hygiene filter, PACK=10 PCS, in individual sterile packs (4170502), hygiene filter, sterile PACK=10 PCS (4171.111), disposable tube set for smoke gas evacuation, sterile (PACK=10 PCS) (4170503), one-pedal footswitch (20301031) and power cable 3 m long (2440.03) 22350311

INSUFFLATOR Highflow 45 EVAC + HEAT Set

bestehend aus: INSUFFLATOR Highflow 45 EVAC + HEAT (2235031), Insufflations-schlauch mit Heizspirale, High-Flow, 3m lang, autoklavierbar (8170202), Insufflationsschlauch, zum Einmalgebrauch mit Heizspirale, High-Flow, mit integriertem Hygienefilter, VE=10 ST, einzeln steril verpackt (4170.502), Hygiene-Filter, VE=10 ST, steril verpackt (4171.111), Rauch-gasabsaugung steril (4170503), Einpedal-Fußschalter (20301031) und Netzkabel 3 m lang (2440.03) 22350311

Necessary accessories:

Connecting hose CO₂ 1,5m NIST-NIST 74021038
with
Pressure reducer CO₂
DIN 477-1 74007.054
DIN EN ISO 407 74007.055
ISO 5145 74007.056

Erforderliches Zubehör:

Verbindungsschlauch CO₂ 1,5m NIST-NIST 74021038
mit
Druckminderer CO₂
DIN 477-1 74007.054
DIN EN ISO 407 74007.055
ISO 5145 74007.056

or
Connecting hose CO₂ 5,0m DIN
for central CO₂ gas supply (Air Liquide) 74021039
Connecting hose CO₂ 5,0m NF
for central CO₂ gas supply (Air Liquide) 74021040

oder
Verbindungsschlauch CO₂ 5,0m DIN
für zentrale CO₂-Gasversorgung (Dräger) 74021039
Verbindungsschlauch CO₂ 5,0m NF
für zentrale CO₂-Gasversorgung (Air Liquide) 74021040

Disposable tube set for smoke gas evacuation,
sterile (PACK=10 PCS) 4170503

Einweg-Schlauchset Rauchgasabsaugung,
steril (VE=10 ST) 4170503

Optional accessories:

Insufflation tube, disposable
with heating element, High-Flow, with integrated hygiene filter,
PACK=10 PCS, in individual sterile packs 4170502

Optionales Zubehör:

Insufflationsschlauch, zum Einmalgebrauch
mit Heizspirale, High-Flow, mit integriertem Hygienefilter,
VE=10 ST, einzeln steril verpackt 4170502

Optional software module:

Software module CAN-BUS, integrated core 2235101
Software module BABY-MODE 2235102
Software module VIDEO-DISPLAY 2235103

Optionale Software-Module:

Softwaremodul CAN-BUS, Integration in core 2235101
Softwaremodul BABY-MODE 2235102
Softwaremodul VIDEOEINBLENDUNG 2235103

INSUFFLATOR Highflow 45

EVAC + HEAT

Technical data

INSUFFLATOR Highflow 45

EVAC + HEAT

Technische Daten

Schutzklasse nach IEC / EN 60601-1 ; (UL 60601-1 / CSA C22.2 No.601.1 - für USA) <i>Protection class complying with IEC / EN 60601-1 ; (UL 60601-1 / CSA C22.2 No.601.1 - for USA)</i>	1
Elektromagnetische Verträglichkeit (EMV) <i>Electromagnetic compatibility (EMC)</i>	gemäß IEC / EN 60601-1-2 <i>according to EN 60601-1-2</i>
Richtlinie über Medizinprodukte 93/42/EWG <i>Medical Device Directive 93/42/EEC</i>	Klasse IIb <i>Class IIb</i>
Schutz gegen elektrischen Schlag <i>Protection against electric shock</i>	Anwendungsteil des Typs CF <i>Application part of Type CF</i>
Schutzgrad gegen Eindringen von Flüssigkeit <i>Degree of protection against penetration of liquids</i>	IP 20 (nicht geschützt) <i>IP 20 (not protected)</i>
Betriebsart <i>Duty cycle</i>	Dauerbetrieb <i>Continuous operation</i>
Schutzgrad bei Anwendung in Gegenwart von brennbaren Gemischen <i>Degree of protection when flammable mixtures are present</i>	Gerät ist nicht explosionsgeschützt (Gerät nicht in zündfähiger Atmosphäre betreiben) <i>This device is not protected against explosions (Do not operate this device in areas where explosive substances are present)</i>
Gewicht <i>Weight</i>	11,0 kg (23,3 lbs) <i>11.0 kg (23.3 lbs)</i>
Abmessungen (B x H x T) <i>Dimensions (W x H x D)</i>	300 mm x 160 mm x 455 mm
Spannung <i>Voltage</i>	100 - 127 / 220 - 240 V~ / a.c.
Frequenz <i>Frequency</i>	50 / 60 Hz
Leistungsaufnahme <i>Power consumption</i>	80 VA
Sicherung <i>Fuse</i>	T 3,15 H <i>T 3.15 H</i>
Stromaufnahme <i>Power rating</i>	0,8 - 0,3 A <i>0.8 - 0.3 A</i>

Relevante Anwendungsparameter / Relevant application parameters:

Insufflationsmedium <i>Insufflation medium</i>	med. CO ₂ (Reinheitsgrad > 99,5 %) <i>med. CO₂ (purity > 99,5 %)</i>
Intraabdominalen Druck <i>Intra-abdominal pressure</i>	3 mmHg bis / to 25 mmHg, (± 2 mmHg) vorwählbar / preselectable in 1 mmHg - Schritten / Steps
Gasflussrate: - Primärfüllung - High Flow <i>Gas flow rate: - primary filling - high flow</i>	1 l/min. (± 50 %) 2 l/min. bis 45 l/min. (± 20 %) vorwählbar in 1 l/min Schritten 1 l/min. 2 l/min. to 45 l/min. (± 20 %) preselectable in 1 l/min steps
Verbrauchsanzeige <i>Consumption display</i>	0 l bis 9999 l (± 20 %) <i>0 l to 9999 l (± 20 %)</i>
Gastemperatur mit Heizschlauch <i>Gas temperature with airbag</i>	37 °C ± 2°C

Laparo CO₂ - Pneu 2233

Laparo - CO₂ - Pneu 2233



- Automatic pressure and flow control
- High degree of safety during laparoscopy
- Functional and user-friendly design
- Max. flow rate 20 l / min

- Automatische Druck- und Flow-Regelung
- Hohe Sicherheit während der Laparoskopie
- Funktionelles und anwenderfreundliches Design
- Max. Flowrate 20 l / min

Laparo CO₂-Pneu 2233 bundle

including:

Laparo-CO₂-Pneu 2233 (2233.001),
insufflation tube, Ø 5 mm, 2.5 m long (8170.101),
hygiene filter, sterile PACK=10 PCS (4171.111),
power cable 3 m long (2440.03) 2233.0011

Laparo-CO₂-Pneu komplett

einschließlich:

Laparo-CO₂-Pneu 2233 (2233.001),
Insufflationsschlauch, Ø 5 mm, 2,5 m lang (8170.101),
Hygiene-Filter, VE=10 ST, steril verpackt (4171.111),
Netzkabel 3 m lang (2440.03) 2233.0011

Necessary accessories:

Connecting hose CO₂ 1,5m NIST-NIST 74021038
Connecting hose CO₂ 5,0m DIN
für zentrale CO₂-Gasversorgung (Air Liquide) 74021039
Connecting hose CO₂ 5,0m NF
für zentrale CO₂-Gasversorgung (Air Liquide) 74021040

Pressure reducer CO₂

DIN 477-1 74007.054
DIN EN ISO 407 (PIN index)..... 74007.055
ISO 5145..... 74007.056

Optimal accessories:

Insufflation tube, disposable
with integrated hygiene filter,
PACK=10 PCS, in individual sterile packs 4170.501

Erforderliches Zubehör:

Verbindungsschlauch CO₂ 1,5m NIST-NIST 74021038
Verbindungsschlauch CO₂ 5,0m DIN
für zentrale CO₂-Gasversorgung (Dräger) 74021039
Verbindungsschlauch CO₂ 5,0m NF
für zentrale CO₂-Gasversorgung (Air Liquide) 74021040

Druckminderer CO₂

DIN 477-1 74007.054
DIN EN ISO 407 (PIN-Index)..... 74007.055
ISO 5145..... 74007.056

Optionales Zubehör:

Insufflationsschlauch, zum Einmalgebrauch
mit integriertem Hygienefilter,
VE=10 ST, einzeln steril verpackt..... 4170.501

Laparo CO₂ - Pneu 2233

Technical data

Laparo - CO₂ - Pneu 2233

Technische Daten

Schutzklasse nach VDE 0750 / IEC 601 <i>Protection class complying with VDE 0750 / IEC 601</i>	1
Elektromagnetische Verträglichkeit (EMV) gemäß EN 60601-1-2 <i>Electromagnetic compatibility (EMC) according to EN 60601-1-2</i>	Klasse B <i>Class B</i>
Klassifikation <i>Classification</i>	CF
EU-Klassifikation <i>EU classification</i>	2 b
Betriebsbedingungen <i>Operating conditions</i>	+10°C bis + 40°C, 30% bis 75% rel. Luftfeuchte <i>+10°C to + 40°C, 30% to 75% rel. humidity</i>
Lager- und Transportbedingungen <i>Storage and transportation conditions</i>	-20°C bis + 60°C, 10% bis 90% rel. Luftfeuchte <i>-20°C to + 60°C, 10% to 90% rel. humidity</i>
Gewicht <i>Weight</i>	ca. / approx. 9.5 kg
Abmessungen (B x H x T) <i>Dimensions (W x H x D)</i>	330 mm x 155 mm x 390 mm
Spannung <i>Voltage</i>	100 - 230 V~ / a.c.
Frequenz <i>Frequency</i>	50 / 60 Hz
Leistungsaufnahme <i>Power consumption</i>	max. 80 VA
Sicherung <i>Fuse</i>	T 2,0 L <i>2.0 L (s.b.)</i>

Relevante Anwendungsparameter / Relevant application parameters:

Insufflationsmedium <i>Insufflation medium</i>	CO ₂
Vorwahl des intraabdominalen Drucks <i>Preselection of intra-abdominal pressure</i>	3 - 25 mm Hg, vorwählbar in 1 mm Hg-Schritten <i>3 - 25 mm Hg, preselectable in 1 mm Hg steps</i>
Gasflussrate: - Primäufüllung - High Flow <i>Gas flow rate</i> - <i>primary filling</i> - <i>high flow</i>	1 l / min. 1 l / min. - 20 l / min., vorwählbar in 1 l / min.-Schritten 1 l / min. 1 l / min. - 20 l / min., preselectable in 1 l / min. steps

VERES Cannulas

for establishing the pneumoperitoneum

VERES-Kanülen

zur Anlage des Pneumoperitoneums

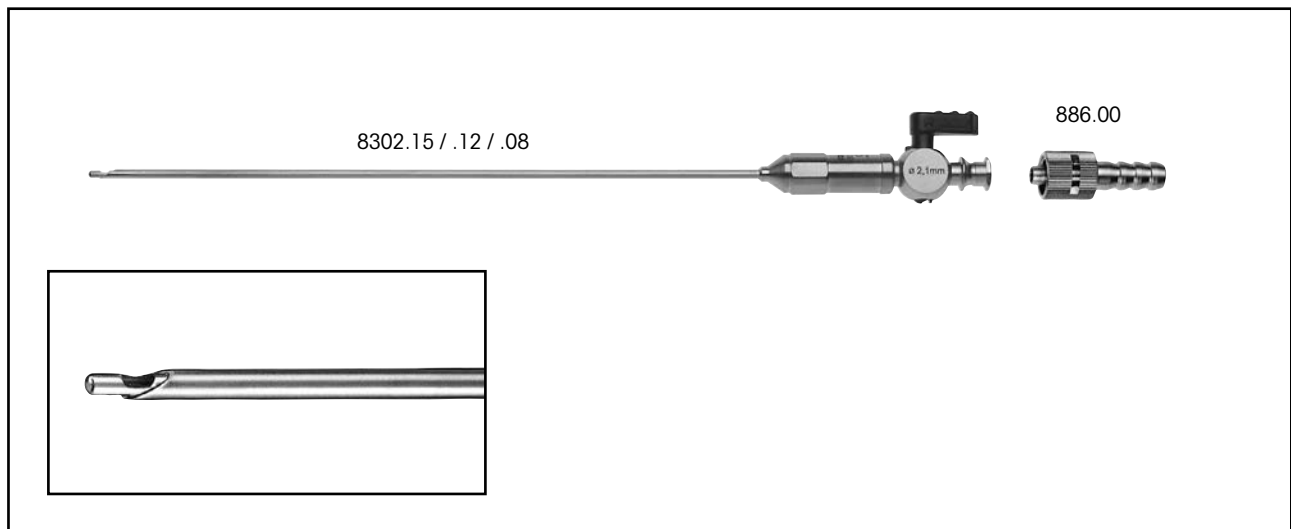

VERES cannula

150 mm working length	8302.15
120 mm working length (standard length)	8302.12
80 mm working length	8302.08

also:

Luer connector	886.00
-----------------------------	--------

VERES-Kanüle

150 mm Nutzlänge	8302.15
120 mm Nutzlänge (Standardlänge)	8302.12
80 mm Nutzlänge	8302.08

hierzu:

Luer-Schlauchteil	886.00
--------------------------------	--------

Smoke-Evacuation Filter
for smoke gas discharge

Rauchgasablassfilter
zur Rauchgasausleitung

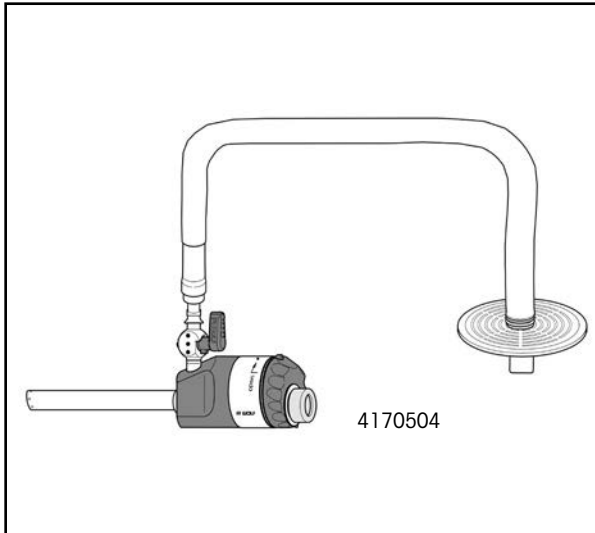

Optionales Zubehör:

Rauchgasablassfilter, steril,

Einmalartikel, VE=10 ST,

einzel steril verpackt 4170504

Optional accessories:

Smoke-evacuation filter, sterile,

single use article, PACK=10 PCS, sterile,

individually packed 4170504

FLUID CONTROL 2225

Suction and irrigation pump

FLUID CONTROL 2225

Saug- und Spülpumpe



Flexibilität

- One pump. Three disciplines.**
Interdisciplinary application in gynecology, urology and general surgery
- No license fee**
Interdisciplinary application without any additional costs
- Individual instrument presets**
for maximum irrigation performance
- Mobile balancing module**
Easy switching between operating theaters
- Compatible with endoscopes from other manufacturers**
when standard mode is selected
- One tube set for all applications**
as a disposable or reusable solution
- Integrated core nova interface**
Control via core nova operating integration system possible

Performance

- 1800 ml/min irrigation performance***
- 2000 ml/min suction performance***
- Continuous irrigation flow** even in small sized instruments
- Integrated vacuum function**
Fast exchange of fluid for optimum visualization conditions
- 60% higher irrigation performance**
compared to previous models

Safety

- Outstanding visualization in any surgical circumstances**
as a result of permanent irrigation flow and vacuum function
- Large, clear touchscreen color display**
- Continuous monitoring and display of fluid deficit**
throughout the entire intervention
- Two integrated weighing cell** for precise balancing
- System monitoring**
Warning messages and signals if there are any deviations

* depending on the discipline and intervention

Flexibilität

- Eine Pumpe. Drei Fachgebiete**
Interdisziplinäre Verwendung in der Gynäkologie, Urologie und Chirurgie
- Keine Lizenzgebühren**
Interdisziplinäre Nutzung ohne zusätzliche Kosten
- Individuelle Instrumenten-Presets**
für maximale Spülleistung
- Mobiles Bilanzierungsmodul**
Einfacher Wechsel zwischen den OP-Sälen
- Kompatibel mit Endoskopen anderer Hersteller**
bei Auswahl des Standard-Modus
- Ein Schlauchset für alle Anwendungen**
als Ein- oder Mehrweg-Lösung
- Integrierte core nova-Schnittstelle**
Steuerung über core nova OP-Integrationssystem möglich

Leistung

- 1800 ml/min Spülleistung***
- 2000 ml/min Absaugleistung***
- Kontinuierlicher Spülstrom**
selbst bei dünnlumigen Instrumenten
- Integrierte Vakuum-Funktion**
Schneller Flüssigkeitsaustausch für optimale Sichtverhältnisse
- 60% höhere Spülleistung** gegenüber Vorgängermodell

Sicherheit

- Hervorragende Sicht in jeder OP-Situation**
durch gleichmäßigen Spülstrom und Vakuum-Funktion
- Großes, übersichtliches Touchscreen-Farbdisplay**
- Durchgängige Kontrolle und Anzeige des Flüssigkeitsdefizits**
während des gesamten Eingriffes
- Zwei integrierte Wiegezellen** für eine genaue Bilanzierung
- Systemüberwachung**
Warnhinweise und -signale bei Abweichungen

* abhängig von Fachdisziplin und Eingriff

FLUID CONTROL 2225

Suction and irrigation pump

FLUID CONTROL 2225

Saug- und Spülpumpe



FLUID CONTROL 2225

Irrigation pump for HYS / URO / LAP

Fluid management for irrigation of irrigation fluids into the uterus and the upper and lower urinary tract, and for the suction-irrigation function in the abdomen

FLUID CONTROL 2225 2225001

FLUID CONTROL 2225, incl. power cable 22250011

FLUID CONTROL 2225

Spülpumpe für HYS / URO / LAP

Fluidmanagement zur Irrigation von Spülflüssigkeiten in den Uterus sowie den oberen und unteren Harntrakt, wie auch zur Saug-Spülfunktion im Abdomen

FLUID CONTROL 2225 2225001

FLUID CONTROL 2225, inkl. Netzkabel 22250011

Balancing module

for hysteroscopy and endourology, fluid management for fluid balancing in combination with FLUID CONTROL 2225, mobile stands with integrated load cells and accommodation for up to 4 irrigation fluid bags 2225023

Bilanzierungsmodul

für die Hysteroskopie und Endourologie, Fluidmanagement zur Flüssigkeitsbilanzierung in Kombination mit FLUID CONTROL 2225, Fahrständer mit integrierten Wiegezellen und Aufnahme für bis zu 4 Spülflüssigkeitsbeutel 2225023

Recommended accessories:

Footswitch

only usable in urology and within the indication TUR / enucleation, possibility of short-term increase in pressure if visualization conditions are poor ("Flush" function) 2204901

Empfohlenes Zubehör:

Fußschalter

verwendbar nur in der Urologie und innerhalb der Indikation TUR / Enukleation, Möglichkeit zur kurzzeitigen Druckerhöhung bei schlechten Sichtverhältnissen ("Flush"-Funktion) 2204901

FLUID CONTROL 2225

Accessories

Irrigation tube set, with piercing connector, 3 m,
with Y-piece, with Luer lock connector,
PACK= 10 PCS, sterile, for single use 4171223

Irrigation tube set, with Care lock, 3 m,
PACK= 10 PCS, sterile, for single use 4171224

Suction-irrigation tube set,
3 m, PACK= 10 PCS, sterile, for single use 4171225

Irrigation tube set, with piercing connector,
with Luer lock connection, incl. 10 replacement membranes,
reusable, 20 x autoclavable 8171223*

Tube set for suction (with 2 ports)
PACK=10 PCS, sterile, for single use T0503-01

Vacuum tube,
silicon, reusable, 20x autoclavable 8170.401*

Vacuum tube with filter, 1.7 m 2206207

Tube adapter,
with Luer lock connector, for suction irrigation handle 8385.901
and tube set 8171223 or 8170.223,
reusable 817123*

Drain tube, 3 m
for suction irrigation handle 8385.901
reusable 8171402

Protective filter for gas filtration for single use 4171.121*

Suction container, 3 l
incl. mounting bracket, reusable 8170.981

Suction container, 3 l
PACK= 2 PCS, for single use 2215.971

Wiring accessories

Patch cable, RJ45 SFTP,
cable length 0.5 m 72325378

cable length 1.0 m 72325429

cable length 10 m 72325434

Plastic cap for network socket, PACK= 8 PCS 5592105

Fuse, 5 x 20, 3,15 AT, VE= 2 ST 64268.007

Power cable, cable length 2.0 m 2440.03

* not for U.S. device

FLUID CONTROL 2225

Zubehör

Spülschlauchset mit Anstechdorn, 3 m
mit Y-Stück, mit Luer-Lock-Anschluss,
VE= 10 ST, steril, zum Einmalgebrauch 4171223

Spülschlauchset mit Care-Lock, 3 m
VE= 10 ST, steril, zum Einmalgebrauch 4171224

Saug-Spülschlauchset 3 m
VE= 10 ST, steril, zum Einmalgebrauch 4171225

Spülschlauchset, mit Anstechdorn,
mit Luer-Lock-Anschluss, inkl. 10 Ersatzmembranen,
wiederverwendbar, 20x autoclavierbar 8171223*

Schlauchset für Absaugung (2 Anschlüsse),
VE= 10 ST, steril, zum Einmalgebrauch T0503-01

Vakuum-Schlauch,
wiederverwendbar, 20x autoclavierbar 8170.401*

Vakuum-Schlauch mit Filter, 1,7 m 2206207

Schlauchansatz
mit Luer-Lock-Anschluss, für Saug-Spül-Handgriff 8385.901
und Schlauchset 8171223 oder 8170.223,
wiederverwendbar 817123*

Saugschlauch, 3 m
für Saug-Spül-Handgriff 8385.901
wiederverwendbar 8171402

Schutzfilter zur Gasfiltration zum Einmalgebrauch 4171.121*

Saug-Behälter, 3 l
inkl. Halterung, wiederverwendbar 8170.981

Saug-Behälter, 3 l
VE= 2 ST, zum Einmalgebrauch 2215.971

Verkabelungszubehör

Patchkabel, RJ45 SFTP,
Kabellänge 0,5 m 72325378

Kabellänge 1,0 m 72325429

Kabellänge 10 m 72325434

Plastikkappe für Netzwerkbuchse, VE= 8 ST 5592105

Sicherung, 5 x 20, 3,15 AT, VE= 2 ST 64268.007

Netzkaabel, Kabellänge 2,0 m 2440.03

* nicht für US-Gerät

Fluid Control LAP 2216

Fluid Control LAP 2216



- Effective irrigation and aspiration of fluids during laparoscopic, minimally invasive surgery
- Simple handling and straightforward unit design
- Optimum irrigation and aspiration performance
- Compatible with suction-irrigation instruments with integrated valves, particularly suitable for modular suction/irrigation handles from R. WOLF
- Extremely safe due to intelligent pressure management
- Simple attachment to irrigator stands or unit trolleys

- Effektives Spülen und Absaugen von Flüssigkeiten im Rahmen der laparoskopischen, minimal invasiven Chirurgie
- Einfaches Handling durch unkomplizierten Geräteaufbau
- Optimale Spül- und Saugleistung
- Kompatibel zu Saug-Spülinstrumenten mit integrierten Ventilen, besonders geeignet für modularen Saug-Spülhandgriff von R. WOLF
- Hohe Sicherheit durch intelligentes Druckmanagement
- Einfache Befestigung an Irrigatorständer oder Gerätewagen

FLUID CONTROL LAP 2216 Set

consisting of:

FLUID CONTROL LAP 2216 (2216001)
and power cable (2440.03) 22160011

FLUID CONTROL LAP 2216 Set

bestehend aus:

FLUID CONTROL LAP 2216 (2216001) und
Netzkabel (2440.03) 22160011

Accessories:

- Tube set with piercing connector,**
(for irrigation), with luer-lock connector, autoclavable,
incl. 10 replacement membranes,
reusable for 20 reprocessing cycles 8171223
- Tube set with piercing connector,**
(for irrigation), with luer-lock connector,
sterile single use item, PACK=10 PCS 4171223
- Tube set with Care-Lock®,**
(for irrigation), sterile single use item, PACK=10 PCS 4171224
- Tube set with piercing connector,**
(for irrigation) with connector for suction-irrigation handle (8385.901),
incl. drain tube, sterile single use item,
PACK=10 PCS 4171225
- Tube set reusable,**
(vacuum tube) autoclavable 8170.401
- Protective filter for gas filtration,** hydrophobic, (hygiene filter) 4171.121
- Suction container PSU,** 3 liter, autoclavable 8170.981
- Suction container,** 3 liter, single use item, PACK=2 2215.971
- Holder,** for fixing the suction container
on irrigator stand or MUT cart 2215.992
- Universal holder,** for FLUID CONTROL LAP 2216
on RIWomobil 32114605

Zubehör:

- Schlauchset mit Anstechdorn,**
(zur Spülung), mit Luer-Lock Anschluss, autoklavierbar,
incl. 10 Ersatzmembranen,
wiederverwendbar für 20 Aufbereitungszyklen 8171223
- Schlauchset mit Anstechdorn,**
(zur Spülung), mit Luer-Lock Anschluss,
steriler Einmalartikel, VE=10 ST 4171223
- Schlauchset mit Care-Lock®,**
(zur Spülung), steriler Einmalartikel, VE=10 ST 4171224
- Schlauchset mit Anstechdorn,**
(zur Spülung), mit Anschlussstück für Saug-Spül-Handgriff
(8385.901), inkl. Ablaufschlauch, steriler Einmalartikel,
VE=10 ST 4171225
- Schlauchset wiederverwendbar,**
(Vakuumschlauch) autoklavierbar 8170.401
- Schutzfilter für Gasfiltration,** hydrophob, (Hygienefilter) 4171.121
- Saugbehälter PSU,** 3 Liter, autoklavierbar 8170.981
- Saugbehälter,** 3 Liter, Einmalartikel, VE= 2 Stück 2215.971
- Halterung,** zum Befestigen für Saugbehälter
am Irrigatorständer oder MUT-Wagen 2215.992
- Universalhalterung,** für FLUID CONTROL LAP 2216
an RIWomobil 32114605

Fluid Control LAP 2216

Technical data















Fluid Control LAP 2216

Technische Daten

Klassifikation gemäß Richtlinie 93/42/EWG <i>Classification in conformity with guideline 93/42/EEC</i>	Ila
Schutzklasse <i>Safety class</i>	I
Schutzgrad <i>Degree of protection</i>	Type BF
Schutzart (IP Code) <i>Protection rating (IP Code)</i>	IP41
Netzanschluss <i>Power supply</i>	100 - 240 V~, 50 / 60 Hz 100 - 240 V a.c., 50 / 60 Hz
Max. Leistungsaufnahme <i>Max. power consumption</i>	52 VA
Max. Stromaufnahme <i>Max. current consumption</i>	100 V: 0,5 A, 240 V: 0,22 A
Maximale Förderleistung <i>Maximum capacity min)</i>	Spülen: 2,0 l/min ($\pm 10\%$), Saugen: 2,0 l/min (+0,4/-0,1 l/min) <i>Irrigation: 2.0 l/min ($\pm 10\%$), Aspiration: 2.0 l/min (+0,4/-0,1 l/</i>
Maximaler Pumpdruck <i>Maximum pump pressure</i>	400 mm Hg (± 50 mm Hg)
Motorabschaltung <i>Motor cut-out</i>	500 mm Hg nach 5 s (± 25 mm Hg)
Saugdruck <i>Suction pressure</i>	zwischen -50 kpa und -60 kpa <i>between -50 kpa and -60 kpa</i>
Anschlüsse <i>Connections</i>	Potentialausgleich, Vakuumanschluss, <i>Equipotential bonding, vacuum connection, service connection</i>
Abmessungen: Breite x Höhe x Tiefe <i>Dimensions: width x height x depth</i>	mit Knebelschraube / with clamping screw 140 x 210 x 295 mm <i>ohne Knebelschraube / without clamping screw 140 x 210 x 200 mm</i>
Gewicht <i>Weight</i>	ca. 4 kg <i>approx. 4 kg</i>
Hergestellt und geprüft nach <i>Manufactured and tested in conformity with</i>	IEC 60601-1 / EN 60601-1















HF Monopolar Connecting Cables

HF-Monopolar Anschlusskabel

Anschluss Instrument <i>Connector for instrument</i>	Anschluss Gerät <i>Connector for unit</i>	Länge <i>Length</i>	Typen <i>Types</i>
WOLF - Resektoskope WOLF resectoscopes 		3 m	815.032
	ERBE (ACC / ICC) / BOWA (EU)	5 m	815.052
		3 m	815.132
	ERBE (T-Serie) ERBE (T series)	5 m	815.152
		3 m	815.031
	Martin (m-Version) / Berchtold / Aesculap	5 m	815.051
HF-Elektroden, monopolar Monopolar HF electrodes 		3 m	815.033
	Bovie / Valleylab / Erbe (Int.) / BOWA (Int.)	5 m	815.053
		3 m	815.034
	BOWA (Int. / EU) Eschmann und andere Geräte mit 4 mm Stecker <i>Eschmann and other devices with 4 mm connectors</i>	5 m	815.054
WOLF - Instrumente WOLF instruments 		3 m	8106.032
	ERBE (ACC / ICC) / BOWA (EU)	5 m	8106.052
		3 m	8106.132
	ERBE (T-Serie) ERBE (T series)	5 m	8106.152
		3 m	8106.031
	Martin (m-Version) / Berchtold / Aesculap	5 m	8106.051
HF-Elektroden, monopolar Monopolar HF electrodes 		3 m	8106.033
	Bovie / Valleylab / Erbe (Int.) / BOWA (Int.)	5 m	8106.053
		3 m	8106.034
	BOWA (Int. / EU) Eschmann und andere Geräte mit 4 mm Stecker <i>Eschmann and other devices with 4 mm connectors</i>	5 m	8106.054

HF Bipolar Connecting Cables

HF-Bipolar Anschlusskabel

Anschluss Instrument <i>Connector for instrument</i>	Anschluss Gerät <i>Connector for unit</i>	Länge <i>Length</i>	Typen <i>Types</i>
 <p>WOLF Bipolar-Zangen <i>WOLF bipolar forceps</i></p>	 ERBE (ACC / ICC / T) / BOWA (EU)	3 m	8108.032
	 Martin (Int.) / 2 pin Valleylab / BOWA (Int.)	3 m	8108.033
	 WOLF / Martin (m-Version) / Berchtold / Aesculap	3 m	8108.031
	 EMC Dolley	5 m	8108.052
	 WOLF / Martin (m-Version) / Berchtold / Aesculap	5 m	8108.051
	 EMC Dolley	3 m	8108035
	 ERBE (ACC / ICC / T) / BOWA (EU)	3 m	8108.132
 <p>Bipolar-Pinzetten Anschluss <i>Bipolar tweezers</i></p>	 ERBE (ACC / ICC / T) / BOWA (EU)	5 m	8108.152
	 Martin (Int.) / 2 pin Valleylab / BOWA (Int.)	3 m	8108.133
	 WOLF / Martin (m-Version) / Berchtold / Aesculap	5 m	8108.153
	 WOLF / Martin (m-Version) / Berchtold / Aesculap	3 m	8108.131
	 EMC Dolley	5 m	8108.151
	 EMC Dolley	3 m	8108135
	 EMC Dolley	3 m	8108135

Flexible Fiber Choledochoscope
5 mm
Channel 2.5 mm

Flexibles Fiber-Choledochoskop
5 mm
Kanal 2,5 mm

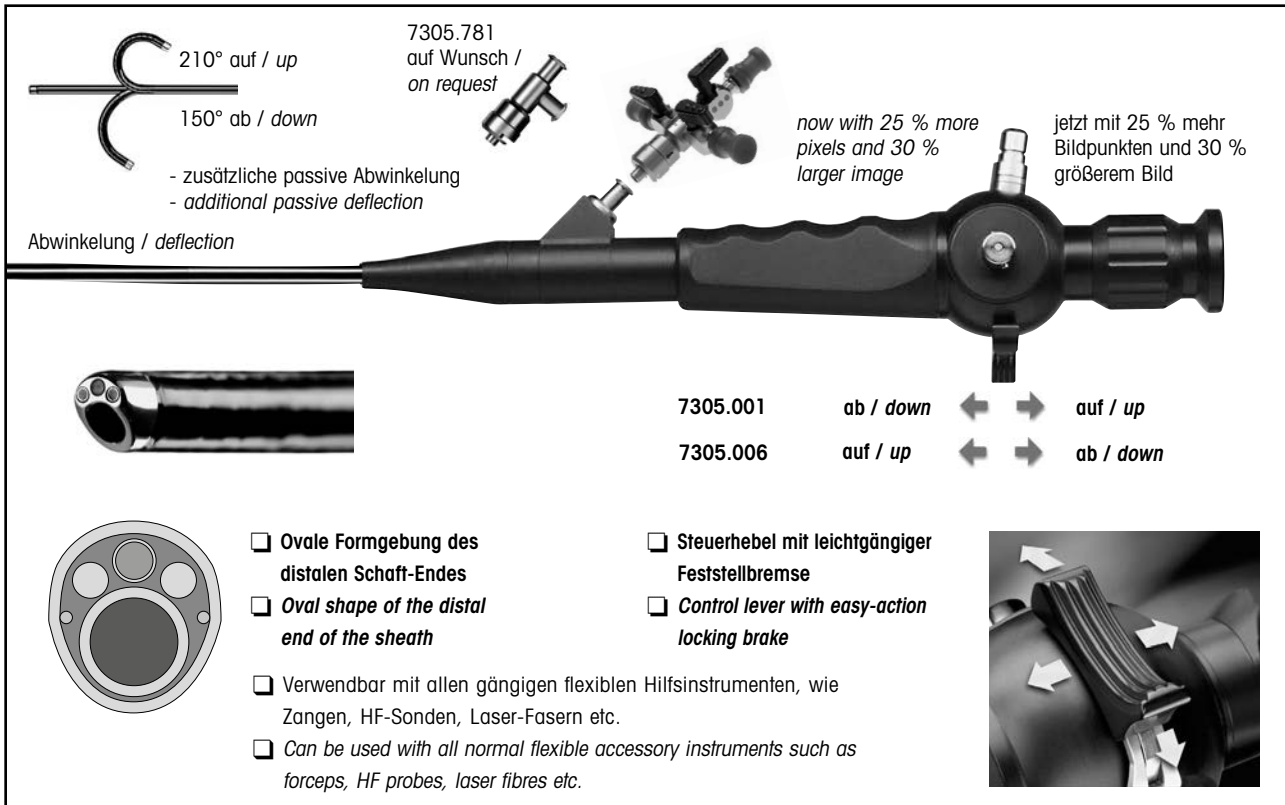

210° auf / up
150° ab / down
- zusätzliche passive Abwinkelung
- additional passive deflection
Abwinkelung / deflection

7305.781
auf Wunsch /
on request

now with 25 % more
pixels and 30 %
larger image
jetzt mit 25 % mehr
Bildpunkten und 30 %
größerem Bild

7305.001 ab / down auf / up
7305.006 auf / up ab / down

- Ovale Formgebung des distalen Schaft-Endes
- Oval shape of the distal end of the sheath
- Steuerhebel mit leichtgängiger Feststellbremse
- Control lever with easy-action locking brake
- Verwendbar mit allen gängigen flexiblen Hilfsinstrumenten, wie Zangen, HF-Sonden, Laser-Fasern etc.
- Can be used with all normal flexible accessory instruments such as forceps, HF probes, laser fibres etc.

- Safe and atraumatic passage through the urethra is provided by the oblique distal tip
- Reduced weight and ergonomic design for optimal handling and less strain on the operator
- 0° viewing direction, 110° angle of view
- Immersible and gas sterilisable

- Sichere und atraumatische Passage der Harnröhre durch angeschrägtes distales Schaft-Ende
- Gewichtsreduzierte Bauweise und ergonomisches Design für optimales Handling und ermüdungsfreies Arbeiten
- 0° Blickrichtung, 110° Bildwinkel
- Einleg- und gassterilisierbar

Flexibles Fiber-Cystoskop komplett Flexible fibre-cystoscope bundle	im Set enthaltenes Fiber-Cystoskop included in set Fiber-cystoscope	Außen-Durchmesser Outer diameter	Sondenkanal Instrument channel	Nutzlänge Working length	Set
bestehend aus: Fiber-Urethro-Cystoskop, Ansatz mit Einführungs- hahn (7305.782), Dichtigkeitstester (163.903), Gassteri-Ventil (163.904), Einmal-Reinigungs- bürste (7990002), Koffer consisting of: Fiber-urethro-cystoscope, instrument port (7305.782), leak tester (163.903), gas sterilisation valve (163.904), disposable cleaning brush (7990002), case	7305.001	5 mm 15 Charr. / Fr.	2.5 mm 7.5 Charr. / Fr.	400 mm	Steuerhebel nach distal - Abwinkelung nach unten Forward movement of the con- trol lever provides downward movement of the tip 730500111
	7305.006				Steuerhebel nach distal - Abwinkelung nach oben Forward movement of the control lever provides upward movement of the tip 730500611

hierzu / also: Fiber Lichtleiter Set , Ø 2,5 mm bestehend aus: Fiber Lichtleiter (80662523), Adapter projektorseitig (8095.07) und Adapter endoskopseitig (809509) Fiber light cable set , Ø 2.5 mm consisting of: Fiber light cable (80662523), adapter projector side (8095.07) and adapter endoscope side (809509)				2.3 m lang / long	806625231
---	--	--	--	----------------------	------------------

15

*Flexible Sensor Endoscope
for use in Choledochoscopy
for ENDOCAM Logic 4K Controller*

*Flexibles Sensor-Endoskop zum
Einsatz in der Choledochoskopie
für ENDOCAM Logic 4K Controller*

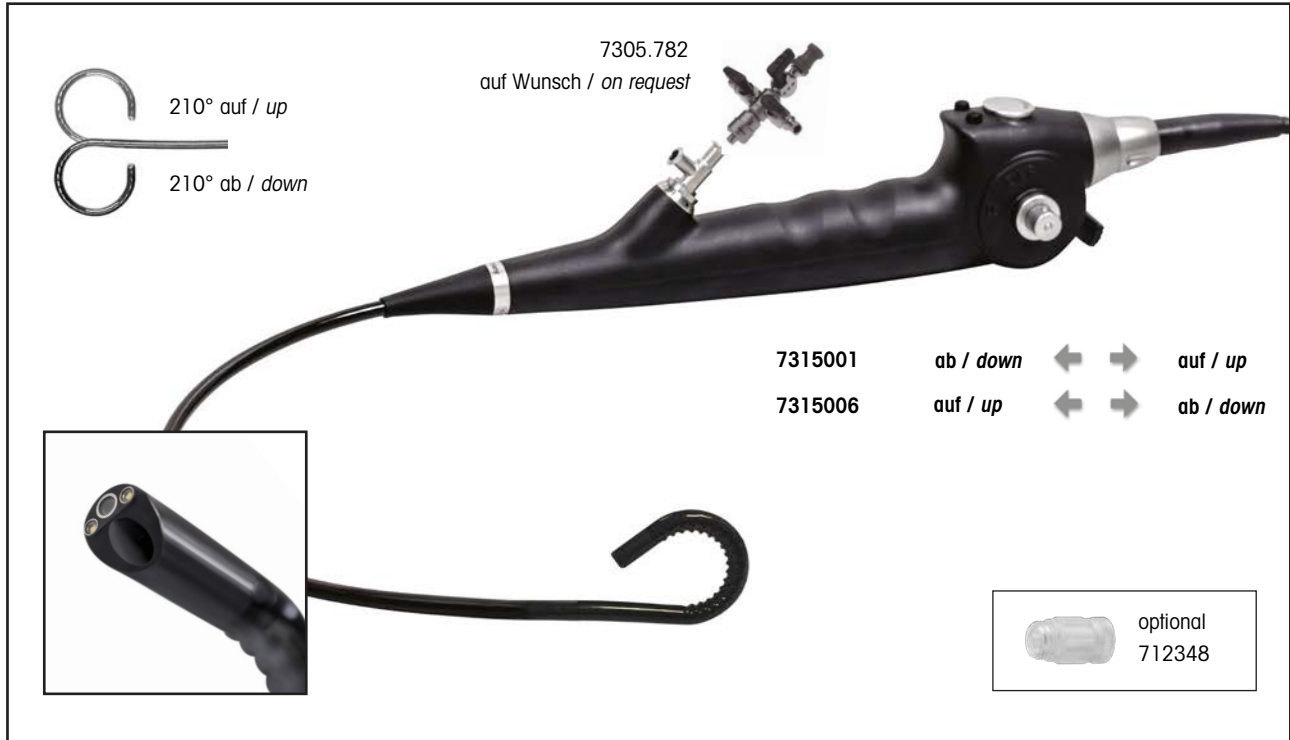

Sensor-cystoscope 16,2 Fr, WL 400 mm,
Ø 11,5/16,2 Fr., working and irrigation channel Ø 7,5 Fr.,
viewing direction 0°, angle of view 110°
forward movement of the control lever distally -
articulation of the tip upwards 7315001
articulation of the tip downwards 7315006

Sensor-Cystoskop 16,2 Ch, NL 400 mm,
Ø 11,5/16,2 Charr., Arbeits- und Spülkanal Ø 7,5 Charr.,
Blickrichtung 0°, Blickwinkel 110°
Steuerhebel nach distal -
Abwinklung nach unten 7315001
Abwinklung nach oben 7315006

Sensor-cystoscope bndl
consisting of:
Leak tester for flex. Endoscopes (163.903)
Pressure equalization valve (163.904)
Rinsing set V (163910)
Cleaning brush Ø 5 mm, TL 1200 mm (VE= 100 ST) (7990004)
Luer-Verschlußskappe (15023205)
Sensor-cystoscope 16.2 Fr., WL 400 mm (7315001)
orward movement of the control lever distally -
articulation of the tip upwards 73150011

Sensor-Cystoskop kpl
bestehend aus:
Dichtigkeitstester für flex Endoskope (163.903)
Druckausgleichsventil (163.904)
Spülset V (163910)
Reinigungsbürste Ø 5 mm, GL 1200 mm (VE= 100 ST) (7990004)
Luer-Verschlußskappe (15023205)
Sensor-Cystoskop 16,2 Ch, NL 400mm (7315001)
Steuerhebel nach distal,
Abwinklung nach unten 73150011

Sensor-cystoscope bndl
consisting of:
Leak tester for flex. Endoscopes (163.903)
Pressure equalization valve (163.904)
Rinsing set V (163910)
Cleaning brush Ø 5 mm, TL 1200 mm (VE= 100 ST) (7990004)
Luer-Verschlußskappe (15023205)
Sensor-cystoscope 16.2 Fr., WL 400 mm (7315006)
forward movement of the control lever distally -
articulation of the tip downwards 73150061

Sensor-Cystoskop kpl
bestehend aus:
Dichtigkeitstester für flex Endoskope (163.903)
Druckausgleichsventil (163.904)
Spülset V (163910)
Einmal-Reinigungsbürste (VE= 100 ST, (7990004)
Luer-Verschlußskappe (15023205)
Sensor-Cystoskop 16,2 CH, NL 400mm (7315006)
Steuerhebel nach distal,
Abwinklung nach unten 73150061

Tuebinger MIC Trainer

Tübinger MIC-Trainer

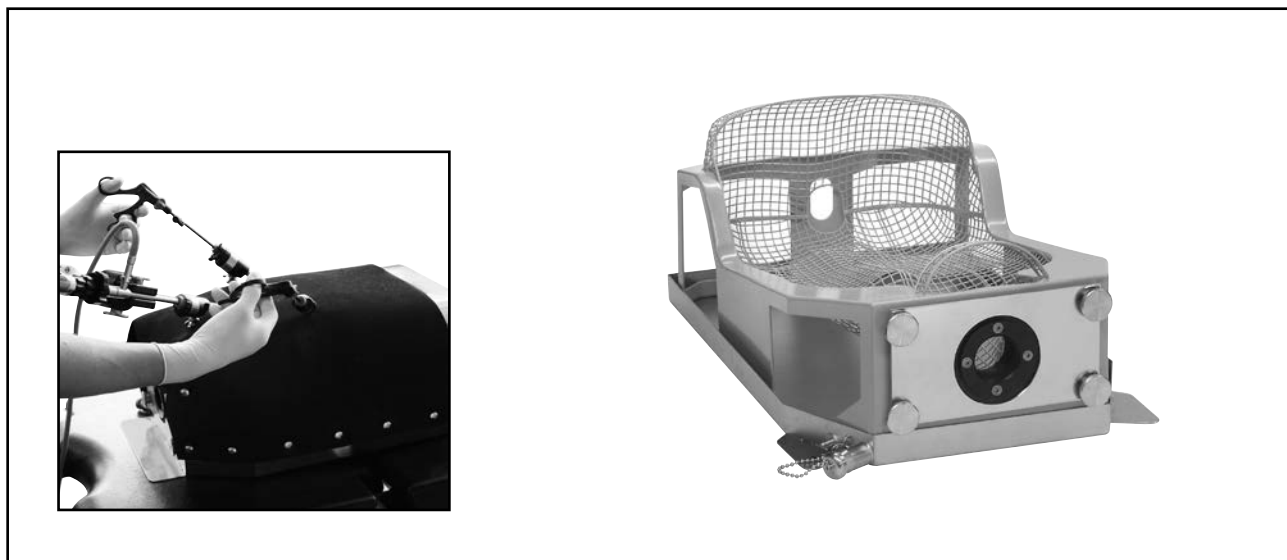

Tuebinger MIC Trainer

with 3 abdominal walls (rubber sponge)

(L x W x H) 550 mm x 340 mm x 220 mm 9500.056

Spare abdominal walls (rubber sponge),

PACK=5 PCS..... 9500.0561

Tübinger MIC-Trainer

mit 3 Bauchdecken (Moosgummi)

(L x B x H) 550 mm x 340 mm x 220 mm 9500.056

Ersatz-Bauchdecken (Moosgummi),

VE=5 ST 9500.0561

16



Auf Wunsch auch mit Transportkoffer lieferbar.

On request available with carrying case.

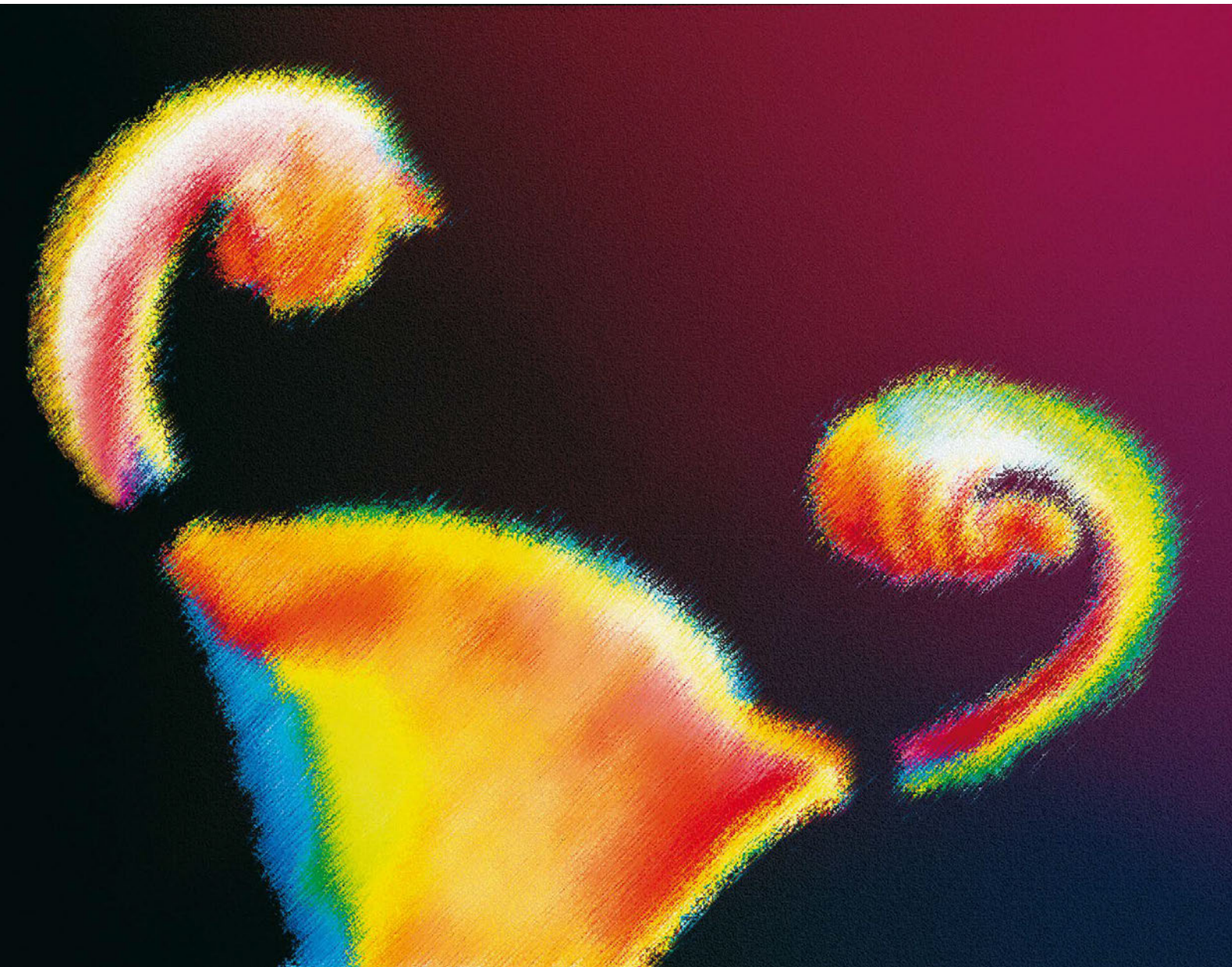

Hysterektomie

Hysterectomy

Hysterectomy

Hysterektomie

1

Secu**Fix** Uterus Manipulator

Secu**Fix** Uterus Manipulator

SecuFIX Uterusmanipulator

System with Colpotransillumination and Vacuum Fixation

SecuFIX Uterusmanipulator

System mit Colpotransillumination und Vakuum-Fixation

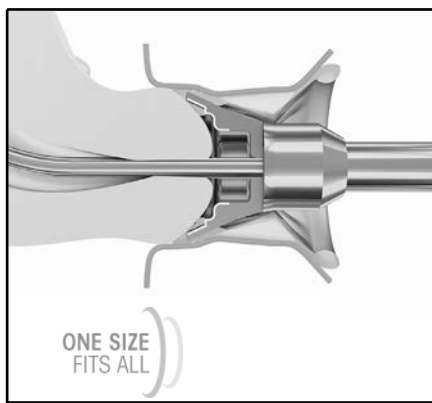
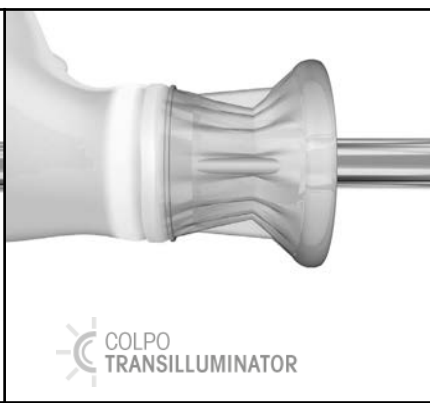
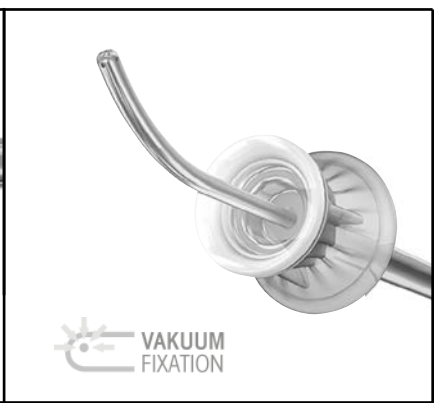

- Atraumatic and safe fixation using vacuum aspiration
 - Colpotransillumination for optimum visualization of the vaginal fornix and an elastic vaginal cuff for reliable gas sealing
 - Universal, conical dome and adjustable uterus probe for adaptation to all anatomical variations
 - Stable modular three-part construction
- Atraumatische Fixation durch Vakuum-Ansaugung
 - Colpotransillumination für eine optimale Darstellung der Schnittkante und elastische Vaginalmanschette zur permanenten Gasabdichtung
 - Universelle, konische Formation und verstellbare Uterussonde zur Anpassung unterschiedlicher Anatomien
 - Stabiler dreiteiliger modularer Aufbau

 <p>ONE SIZE FITS ALL</p>	 <p>COLPO TRANSILLUMINATOR</p>	 <p>VAKUUM FIXATION</p>
<p>Durch die konische Formation der Manipulator Glocke und die Abstufungen in der Kappe selbst ist ein Ansaugen der Portio unterschiedlicher Größen möglich. Die elastische Vaginalmanschette sorgt für eine optimale Abdichtung der Scheide und somit für ein stabiles Pneumoperitoneum in allen Phasen des Eingriffs.</p> <p><i>The conical shape of the manipulator dome and the gradations in the cap itself mean that portios of all sizes can be accommodated. The elastic vaginal cuff guarantees an optimum seal for the vagina and hence a stable pneumoperitoneum through all phases of the intervention.</i></p>	<p>Die ringförmige Illumination sorgt für die optimale Darstellung der Schneidekante und dient gleichzeitig als Ausleuchtungsunterstützung während des vaginalen Anlegens des Manipulators.</p> <p><i>The annular illumination provides optimum visualization of the cutting edge and at the same time serves as supporting illumination while the manipulator is positioned in the vagina.</i></p>	<p>Die Ansaugung in der Gebärmutter und im Zervix ermöglicht die atraumatische und sichere Fixation. Die intraperitoneale Zellverschleppung wird dadurch vermieden.</p> <p><i>The aspiration in the uterus and in the cervix permits atraumatic and secure fixation. This avoids intraperitoneal cell dislocation.</i></p>

SecuFIX Uterusmanipulator

System with Colpotransillumination and Vacuum Fixation

SecuFIX Uterusmanipulator

System mit Colpotransillumination und Vakuum-Fixation

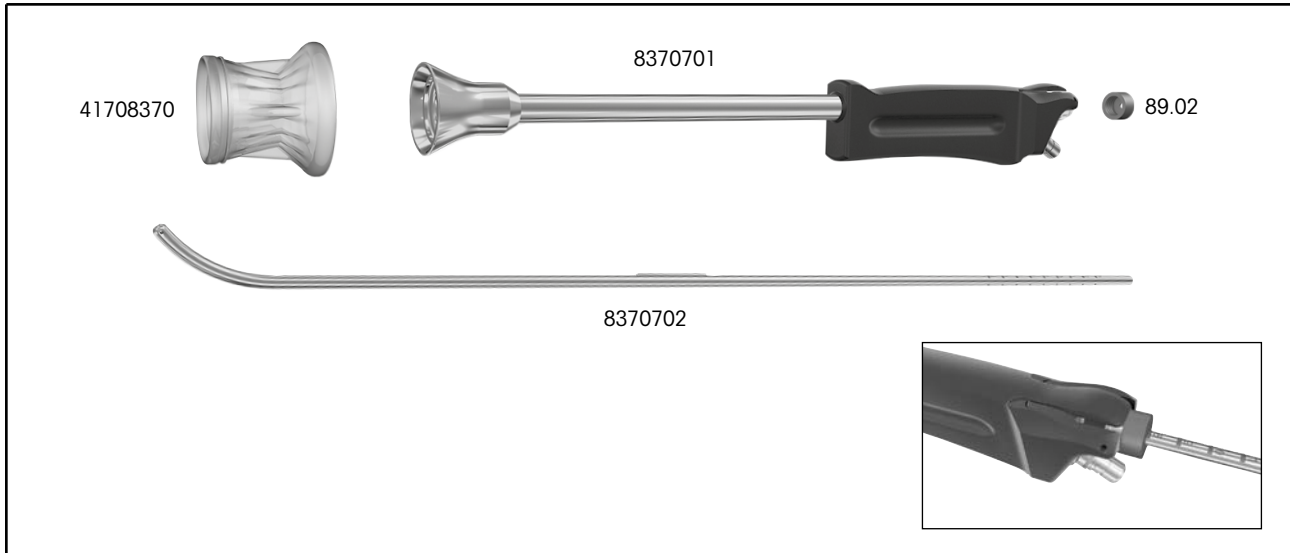

SecuFIX

Uterusmanipulator bndl

comprising:

SecuFix Uterus Manipulator (8370701), Uterus Probe with longitudinal scale (8370702), Colpotransilluminator vacuum tube, (PACK= 10 PCS, packed singly, sterile) (41708370), cleaning brush Ø 5 mm, TL 515 mm (6.05), cleaning brush (6.09), seal cap 3.4-5.1mm (pack of 10) (89.02) 83707011



Accessories:

Fiber light cable bndl,

fiber bundle Ø 3.5 mm (color marking orange),
length 2.3 m 806635231

Irrigation tube L 0.6m

for machine cleaning 163915

Container (wxhxd) 500x60x200mm

with instrument mat,
inner dimensions (wxhxd): 500x57x200mm,
outer dimensions (BxHxT): 566x77x266mm 33024

SecuFIX

Uterusmanipulator kpl

bestehend aus:

Uterusmanipulator Ø 36 mm (8370701), Uterussonde Ø 5 mm (8370702), Colpotransilluminator Vakuumschlauch (VE=10 ST, einzeln steril verpackt) (41708370), Reinigungsbürste (6.05), Reinigungsbürste Ø 5 mm, GL 515 mm (6.09), Dichtungskappe DL 3,4-5,1mm (VE=10 St.) (89.02) 83707011

SecuFIX

Colpotransilluminator Vakuumschlauch

(VE=10 ST, einzeln steril verpackt)

mit Rückschlagventil, Sauganschluss, Y-Verbindungsteil bei Verwendung eines Sauginstrumentes bei gleichem Absauggerät, Schlauchklemme, Einmalgebrauchsartikel 41708370

SecuFIX

Colpotransilluminator vacuum tube

(PACK=10 PCS, packed singly, sterile)

with nonreturn valve, suction connector, Y-shaped adapter for use with a suction instrument on the same suction unit, suction clamp, for single use 41708370

Zubehör

Fiber Lichtleiter kpl,

Faserbündel-Ø 3,5 mm, (Farbmarkierung orange),
Länge 2,3 m 806635231

Spülschlauch L 0,6m

für die maschinelle Reinigung 163915

Behälter (BxHxT) 500x60x200mm

mit Instrumentenmatte
Innenmaße (BxHxT): 500x57x200mm,
Außenmaße (BxHxT): 566x77x266mm 33024

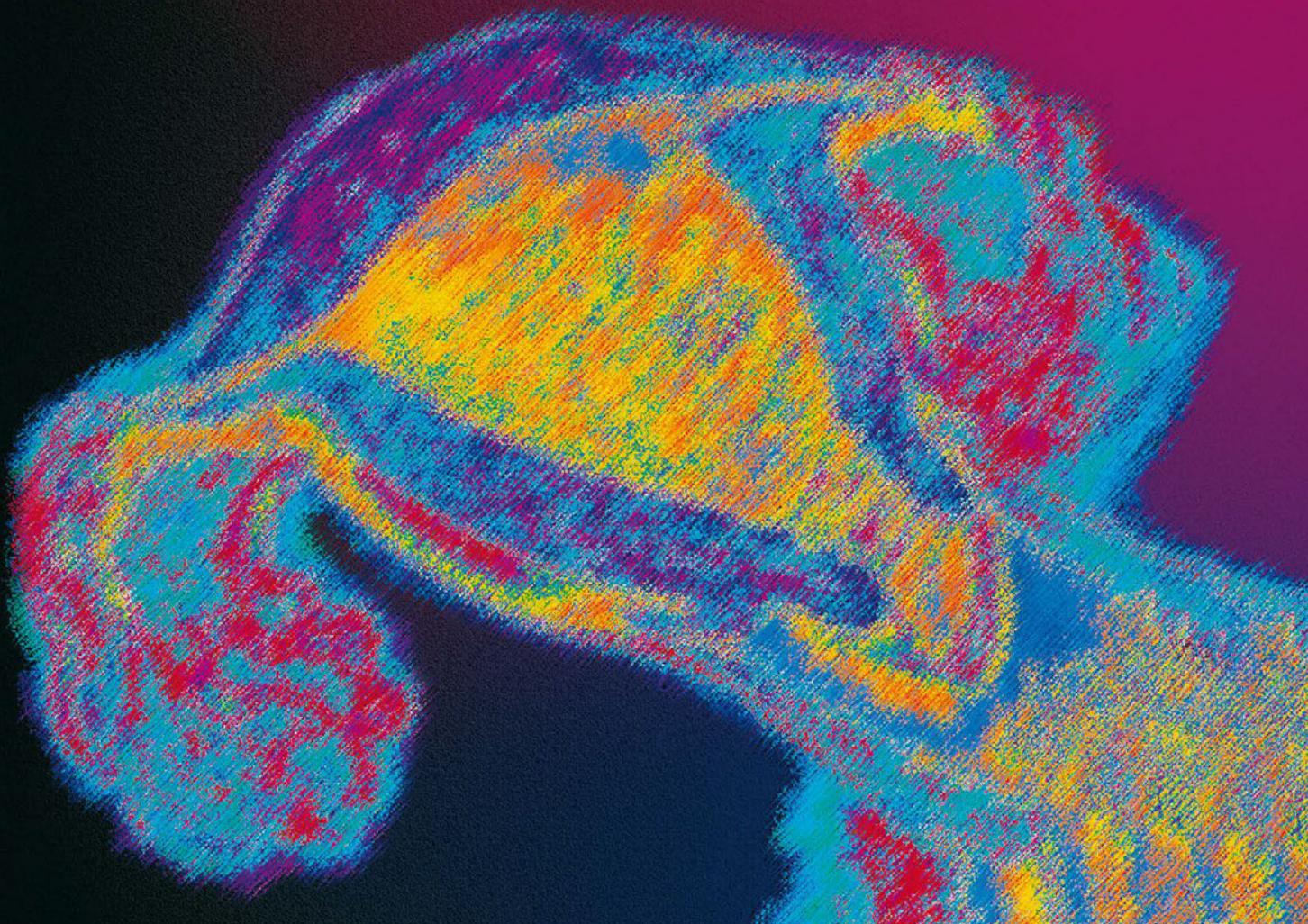

**Diagnostische und operative
Hysteroskopie**

***Diagnostic and operative
Hysteroscopy***





Diagnostic and operative Hysteroscopy

Diagnostische und operative Hysteroskopie

1	<i>Basic Sets</i>	Basis-Sets
2	<i>Telescopes</i>	Optiken
3	<i>For 2.7 mm Telescope: Hysteroscope Sheaths / Inserts</i>	Für 2,7 mm-Optik: Hysteroskop-Schäfte / Einsätze
4	<i>For 4 mm Telescope: Hysteroscope Sheaths</i>	Für 4 mm-Optik: Hysteroskop-Schäfte
5	<i>Compact Hysteroscope Ø 3.8 mm, 30°</i>	Kompakt-Hysteroskop Ø 3,8 mm, 30°
6	<i>Compact Hysteroscope Ø 5 mm, 20°</i>	Kompakt-Hysteroskop Ø 5 mm, 20°
7	<i>Rigid Forceps 7 Fr.</i>	Starre Zange 7 Charr.
8	<i>Forceps / Scissors micro modular system HySafe</i>	Zangen / Scheren Kleinmodulares System HySafe
9	<i>Flexible Forceps 3 Fr.</i>	Flexible Zangen 3 Charr.
10	<i>Electrodes, bipolar, monopolar</i>	Elektroden, bipolar, monopolar
11	<i>Instruments for Cervix and Uterus</i>	Instrumente für Portio und Uterus
12	<i>Hystero Resection</i>	Hystero-Resektion
13	<i>Flexible Hysteroscope</i>	Flexibles Hysteroskop
14	<i>Units</i>	Geräte
15	<i>HF Connecting Cables</i>	HF-Anschlusskabel

*Basic Set for Diagnostic
Hysteroscopy*

**Basis-Set zur diagnostischen
Hysteroskopie**

ohne Arbeitskanal without working channel		
	PANOVIEW Optik, 30°, 2,7 mm <i>PANOVIEW Telescope, 30°, 2.7 mm</i>	8974.402
	Schaff für Hysteroskop 10,5 Ch <i>Sheath for hysteroscope 10,5 Fr</i>	8985.11
	PE-Zange kpl, starr, 5 Charr. <i>Biopsy forceps bndl, rigid, 5 Fr.</i>	8642.6312
	Greifzange kpl, starr, 5 Charr. <i>Grasping forceps bndl, rigid, 5 Fr.</i>	8642.6502
alternativ alternatively		
	Hysteroskop kpl 3,8mm bestehend aus: Kompakt-Hysteroskop 30° (8986402) und Gummikappe "RIWO", rot (VE=10 St., 88.01) Hysteroscope bndl 3.8mm consisting of: Compact Hysteroscope 30° (8986402) and rubber cap "RIWO", red (pack of 10, 88.01)	89864021











1

Basic Set Hystero-Resectoscope

PRINCESS[®] E-line & S(a)line System,
Telescope 2.7 mm, 12°
21 Fr., passive, continuous irrigation

Basis-Set Hystero-Resektoskop

PRINCESS[®] E-line & S(a)line System,
Optik 2,7 mm, 12°,
21 Charr., passiv, Dauerspülung

	Außenschaft, 21 Charr. <i>Outer sheath, 21 Fr.</i>	8653.021
	Innenschaft, 19 Charr. <i>Inner sheath, 19 Fr.</i>	8653.018
	Obturator <i>Obturator</i>	8653.18
	Arbeitselement, offen, passiv <i>Working elements, open, passive</i>	8653.224
	PANOVIEW Optik, 12°, <i>PANOVIEW telescope, 12°</i>	8974.412
	Schneide-Elektrode, bipolar, VE= 3 ST, einzeln steril verpackt <i>Cutting electrode, bipolar, PACK=3 PCS, sterile individually packaged</i>	4653.1313
	Rollen-Elektrode, bipolar, VE= 3 ST, einzeln steril verpackt <i>Roller electrode, bipolar, pack of 3, sterile individually packaged</i>	4653.023
	Haken-Elektrode, monopolar und bipolar <i>Hook electrode, monopolar and bipolar</i>	865303
	Sterilisations-Schutzhülse <i>Protective sterilization sleeve</i>	8428.901
	HF-Bipolar Anschlusskabel <i>HF bipolar connecting cable</i>	8108...
	FLUID CONTROL 2225 Saugpumpe / <i>irrigation pump</i>	22250011
	mit / <i>with</i> Bilanzierungsmodul / <i>Balancing modul</i>	2225023

1

Mini Fibre Hysteroscope
2 mm, 0°

Mini-Fiber-Hysteroskop
2 mm, 0°

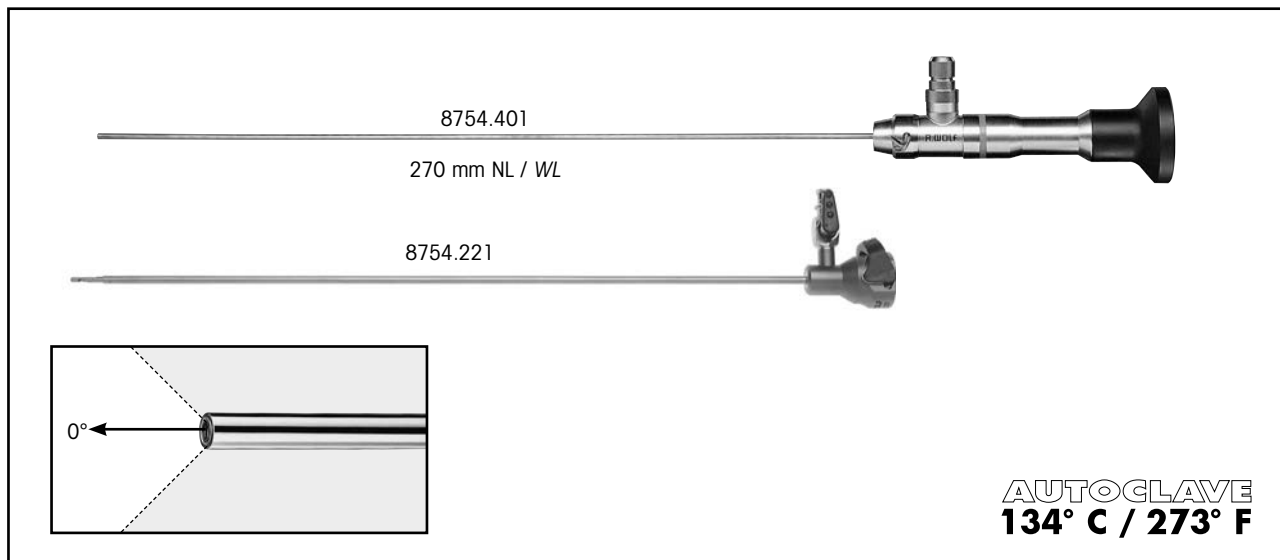

2

WL 270 mm standard version

Telescope

Ø 2 mm, 0° 8754.401

Outer sheath

Ø 2,8 mm, with insufflation tap, WL 250 mm 8754.221

NL 270 mm Standard-Ausführung

Optik

Ø 2 mm, 0° 8754.401

Außenschaft

Ø 2,8 mm, mit Insufflationshahn, NL 250 mm 8754.221

Recommended light cable:

Fiber light cable bndI, Ø 2.5 mm, 2.3 m long consisting of:

Fiber light cable (80662523), adapter projector-side (8095.07) and adapter endoscope-side (809509) 806625231 (for maximum light transmission)

Accessories:

Perf. basket for standard telescope 2

Dimensions (l x w x h): 481 x 59 x 54 mm 38016

Empfohlenes Lichtleitkabel:

Fiber Lichtleiter kpl, Ø 2,5 mm, 2,3 m lang bestehend aus:

Fiber Lichtleiter (80662523), Adapter projektorseitig (8095.07) und Adapter endoskopseitig (809509) 806625231 (für maximale Lichttransmission)

Zubehör:

Siebkorb für Standardoptik 2

Abmessungen (L x B x H) 481 x 59 x 54 mm 38016

Mini Operating Hysteroscope, by Solima-Zupi

Mini-OP-Hysteroskop nach Solima-Zupi

2

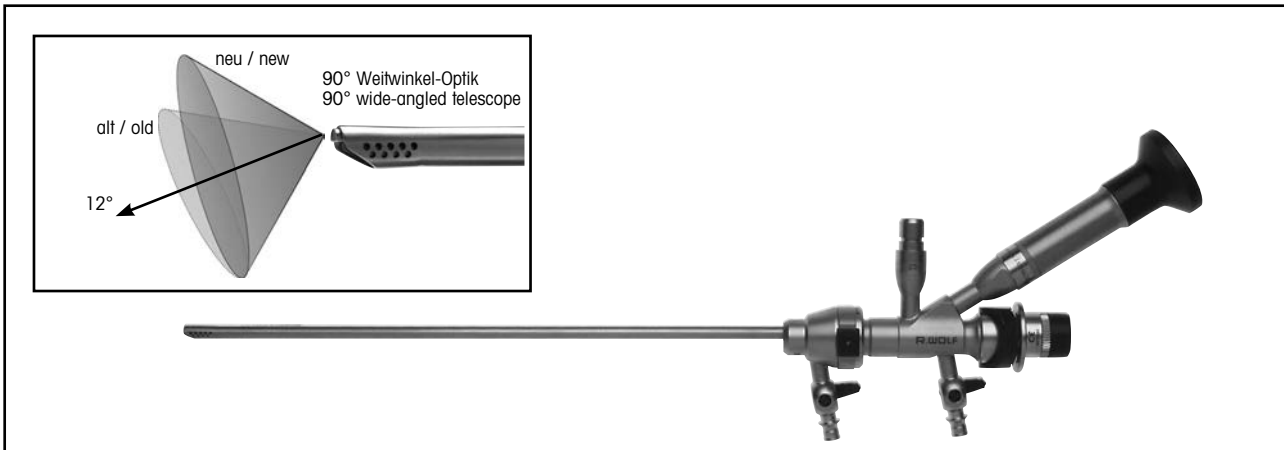

Farbmarkierung / Colour code	Außen-Ø / Outer-Ø	Arbeitskanal / Working channel	Aussenschaft / Outer sheath	Innenschaft / Inner sheath	Basis Optik / Basic telescope 2 mm, 12°
gelb / yellow	3.8 mm	3 Ch. / Fr.	8753.001	8753.002	8753.411
blau / blue	4.8 mm	5 Ch. / Fr.	8753.003	8753.004	
grün / green	5.4 mm	7 Ch. / Fr.	8753.006	8753.007	
weiß / white	5.8 mm	9 Ch. / Fr.	8753.008	8753.009	

- | | |
|--|---|
| <ul style="list-style-type: none"> <input type="checkbox"/> Modular construction for one basic telescope <input type="checkbox"/> High resolution fibre-optic system, 50.000 pixels and 12° direction of view <input type="checkbox"/> Automatic seal on instrument port - single handed operation <input type="checkbox"/> Snap-on connection <input type="checkbox"/> Very effective flow characteristics <input type="checkbox"/> Straight instrument channel | <ul style="list-style-type: none"> <input type="checkbox"/> Modularer Aufbau um eine Basis-Optik <input type="checkbox"/> Hochauflösendes fiberoptisches System, 50.000 Pixel und 12° Blickrichtung <input type="checkbox"/> Automatische Dichtung für den Arbeitskanal - Einhandbedienung <input type="checkbox"/> Schnappverschluss <input type="checkbox"/> Sehr effektive Spülleistung <input type="checkbox"/> Gerader Instrumentenkanal |
|--|---|

Spezielles Zubehör / Special accessories:		
	Starre Fasszange 3 mm, NL 340 mm Grasping forceps 3 mm, WL 340 mm	8993.235

Recommended light cable:

Fiber light cable bndI, Ø 2.5 mm, 2.3 m long
consisting of:

Fiber light cable (80662523), adapter projector-side (8095.07) and
adapter endoscope-side (809509) 806625231
(for maximum light transmission)

Empfohlenes Lichtleitkabel:

Fiber Lichtleiter kpl, Ø 2,5 mm, 2,3 m lang
bestehend aus:

Fiber Lichtleiter (80662523), Adapter projektorseitig (8095.07) und
Adapter endoskopseitig (809509) 806625231
(für maximale Lichttransmission)

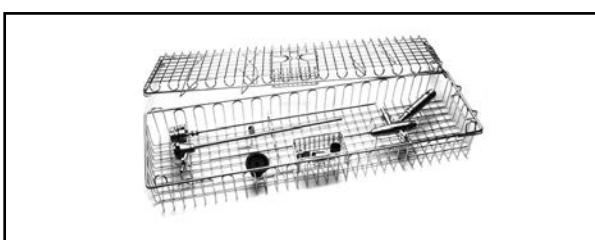

Siebkorb für Hysteroskop 1

zur Aufnahme für Wechselschäfte, mit Kleinteilesieb,
Innenmaße (BxHxT): 451x65x124mm,
Außenmaße (BxHxT): 467x75x132mm 38006

Perforated basket for hysteroscope 1

for holding replacement sheaths, with smallpart basket,
inner dimensions (wxhxd): 467x65x132mm,
outer dimensions (wxhxd): 467x75x132mm 38006

Hysteroscope Telescopes
2.7 mm

Hysteroskop-Optiken
2,7 mm

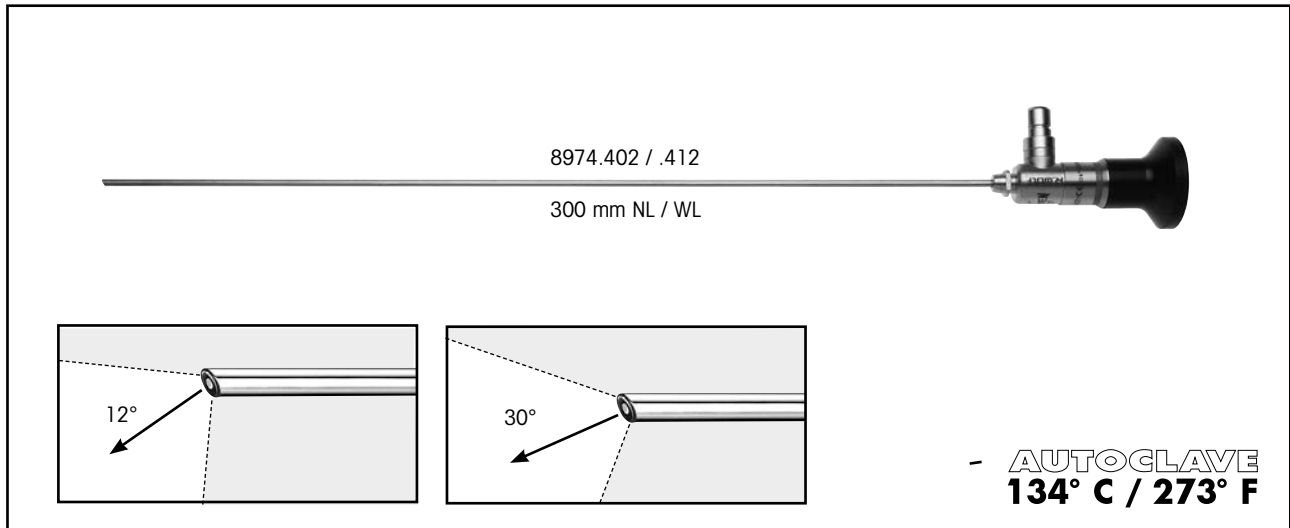

2

PANOVIEW telescope, Ø 2.7 mm,

12°	8974.412
30°	8974.402

PANOVIEW Optik, Ø 2,7 mm,

12°	8974.412
30°	8974.402

Recommended light cable:

Fiber light cable bndI, Ø 2.5 mm, 2.3 m long consisting of:

Fiber light cable (80662523), adapter projector-side (8095.07) and adapter endoscope-side (809509) 806625231
(for maximum light transmission)

Accessories:

Perf. basket for standard telescope 2

Dimensions (l x w x h): 481 x 59 x 54 mm 38016

Empfohlenes Lichtleitkabel:

Fiber Lichtleiter kpl, Ø 2,5 mm, 2,3 m lang bestehend aus:

Fiber Lichtleiter (80662523), Adapter projektorseitig (8095.07) und Adapter endoskopseitig (809509) 806625231
(für maximale Lichttransmission)

Zubehör:

Siebkorb für Standardoptik 2

Abmessungen (L x B x H) 481 x 59 x 54 mm 38016

Hysteroscope Telescope
4 mm, 30°

Hysteroskop-Optik
4 mm, 30°

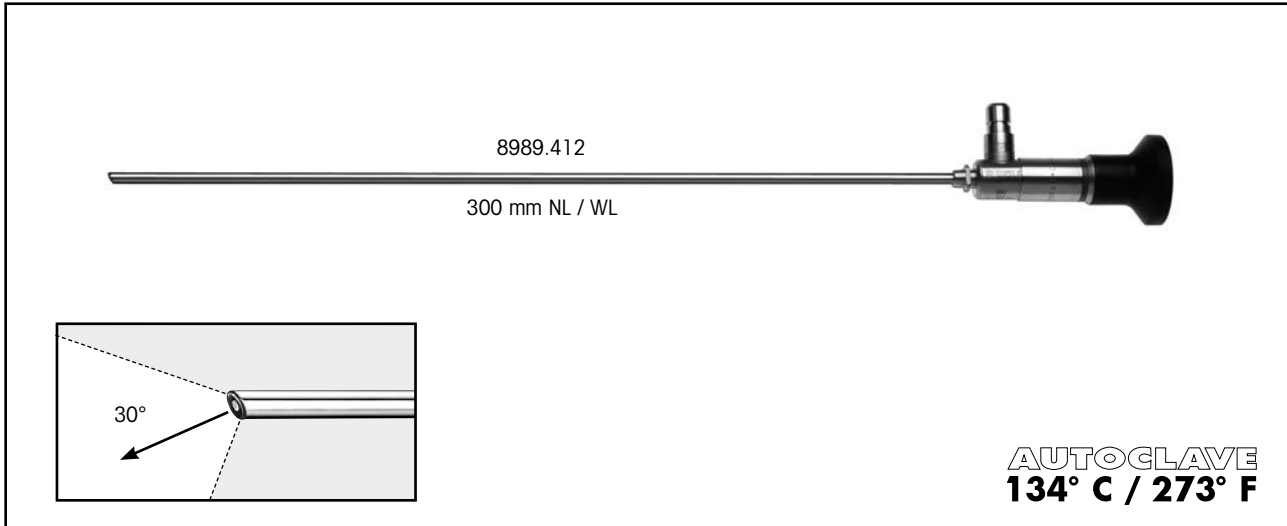

2

PANOVIEW PLUS telescope, Ø 4 mm,
30° 8989.412

PANOVIEW PLUS-Optik, Ø 4 mm,
30° 8989.412

Recommended light cable:

Fiber light cable set Ø 3.5 mm, 2300 mm long
consisting of:

Fiber light cable (80663523), adapter projector-side (8095.07) and
adapter endoscope-side (809509) 806635231
(for maximum light transmission)

Accessories:

Perf. basket for standard telescope 2
Dimensions (L x w x h): 481 x 59 x 54 mm 38016

Empfohlenes Lichtleitkabel:

Fiber Lichtleiter Set, Ø 3,5 mm, 2300 mm lang
bestehend aus:



Fiber Lichtleiter (80663523), Adapter projektorseitig (8095.07) und
Adapter endoskopseitig (809509) 806635231
(für maximale Lichttransmission)

Zubehör:

Siebkorb für Standardoptik 2
Abmessungen (L x B x H) 481 x 59 x 54 mm 38016

*Diagnostic CO₂ Hysteroscope
Sheath 10.5 Fr. / Ø 3.5 mm
for telescope 2.7 mm, 30°*

Diagnostik-CO₂-Hysteroskop-
Schaft 10,5 Charr. / Ø 3,5 mm
für Optik 2,7 mm, 30°

			
	Schaft / Sheath	NL / WL	Typen / Types
 Schaft für Hysteroskop 10,5CH <i>Sheath for hysteroscope 10.5FR</i>	10.5 Charr. / Fr. Ø 3.5 mm	255 mm	8985.11
Handgriff für Hysteroskop <i>Handle for hysteroscope</i>			8986.251



3

*Continuous-Irrigation Diagnostic
Hysteroscope Sheath 12 Fr., oval
for telescope 2.7 mm, 30°*

*Diagnostik-Dauerspül-
Hysteroskop-Schaft 12 Charr., oval
für Optik 2,7 mm, 30°*

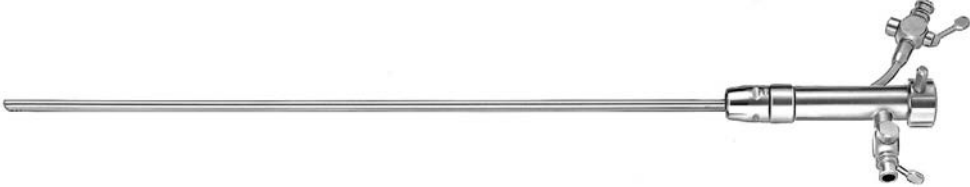

3



	Schaft / Sheath	Arbeitskanal / Working channel	NL / WL	Typen / Types
 <p>Schaft für Hysteroskop 12CH Sheath for hysteroscope 12FR</p>	12 Charr. / Fr.	3 Charr. / Fr.	245 mm	8974.121
<p>Handgriff für Hysteroskop Handle for hysteroscope</p>				8986.251

OptiFLOW™ Continuous-Flow
Operating sheath 5.5 mm
 for telescope 2.7 mm, 12° and 30°

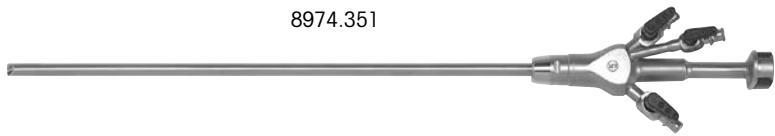
OptiFLOW™ Highflow-Dauerspül-
Operations-Schaft 5,5 mm
 für Optik 2,7 mm, 12° und 30°

 <p>8974.351</p>				
	Schaft / Sheath	Arbeitskanal / Working channel	NL / WL	Typen / Types
 <p>Schaft für Hysteroskop 16,5CH Sheath for hysteroscope 16.5FR</p>	16.5 Charr. / Fr. Ø 5.5 mm	5 Charr. / Fr.	219 mm	8974351
<p>Handgriff für Hysteroskop Handle for hysteroscope</p>				8986.251

3

also:

PANOVIEW telescope, Ø 2.7 mm,
 12° 8974.412
 30° 8974.402

hierzu:

PANOVIEW Optik, Ø 2,7 mm,
 12° 8974.412
 30° 8974.402

Recommended light cable:

Fiber light cable bndl, Ø 2.5 mm, 2.3 m long consisting of:
 Fiber light cable (80662523), adapter projector-side (8095.07)
 and adapter endoscope-side (809509) 806625231
 (for maximum light transmission)

For sterilising:

Container (wxhxd) 400x60x200mm
 inner dimensions (wxhxd): 400x57x200mm,
 outer dimensions (BxHxT): 466x77x266mm 33022

empfohlenes Lichtleitkabel:

Fiber Lichtleiter kpl, Ø 2,5 mm, 2,3 m lang bestehend aus:
 Fiber Lichtleiter (80662523), Adapter projektorseitig (8095.07)
 und Adapter endoskopseitig (809509) 806625231
 (für maximale Lichttransmission)

Zur Aufbereitung:

Behälter (BxHxT) 400x60x200mm
 Innenmaße (BxHxT): 400x57x200mm,
 Außenmaße (BxHxT): 466x77x266mm 33022

Diagnostic CO₂ Hysteroscope
Sheath 15 Fr.
for telescope 4 mm, 30°



Diagnostik-CO₂-Hysteroskop-
Schaff 15 Charr.
für Optik 4 mm, 30°

by Lindemann

nach Lindemann





3

	Schaff / Sheath	NL / WL	Typen / Types
 <p>Schaff für Hysteroskop 15CH mit distalen Längsschlitzen Sheath for hysteroscope 15 FR with openings at the distal tip</p>	15 Charr. / Fr.	255 mm	8989.151
<p>Handgriff für Hysteroskop Handle for hysteroscope</p>			8986.251

*Continuous-Irrigation Diagnostic
Hysteroscope Sheath 15 Fr., oval
for telescope 4 mm, 30°*

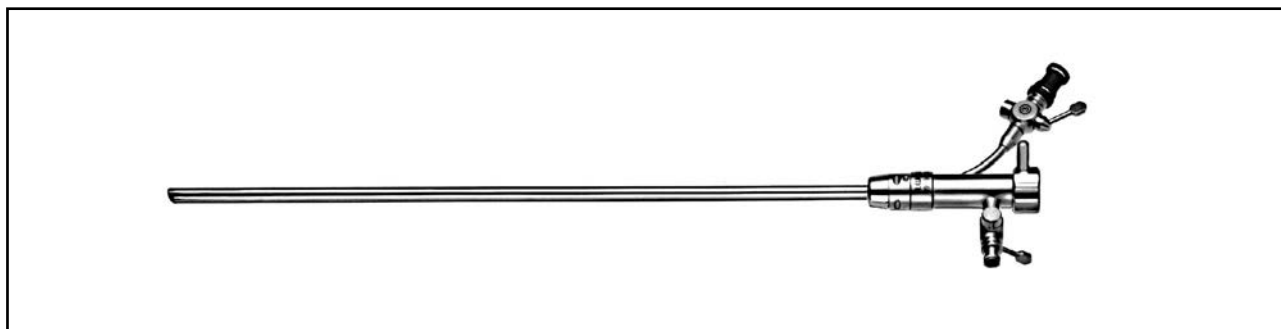
*Diagnostik-Dauerspül-
Hysteroskop-Schaft 15 Charr., oval
für Optik 4 mm, 30°*



	Schaft / Sheath	Arbeitskanal / Working channel	NL / WL	Typen / Types
 <p>Schaft für Hysteroskop 15CH mit zwei Luer-Lock-Schlauchteilen (886.00) und Gummikappe (88.005) Sheath for hysteroscope 15 FR with Luer tube connections (886.00) and rubber cap (88.005)</p>	15 Charr. / Fr.	3 Charr. / Fr.	230 mm	8989.031
<p>Handgriff für Hysteroskop Handle for hysteroscope</p>				8986.251

4

Use of flexible auxiliary instruments possible in inlet channel

Anwendung von flexiblen Hilfsinstrumenten bis 3 Charr. über den Zulaufkanal möglich

*Continuous-Irrigation Operating
Hysteroscope Sheath 21 Fr.
for telescope 4 mm, 30°*

*Operations-Dauerspül-
Hysteroskop-Schaft 21 Charr.
für Optik 4 mm, 30°*

by Gallinat

8988.031



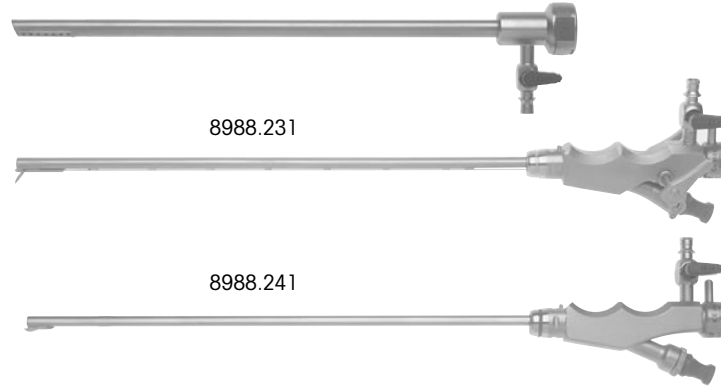

nach Gallinat



8988.231



8988.241

4

	Schaft / Sheath	Arbeitskanal / Working channel	NL / WL	Typen / Types
 <p>Außenschaft für Hysteroskop 21CH mit abgeschrägtem distalem Ende und drehbarem Ablaufhahn, sowie Schnellverschluss Outer sheath for hysteroscope 21FR with oblique distal tip, swivel outlet tap and fast locking connector</p>	21 Charr. / Fr.		204 mm	8988.031
 <p>Obturator für Hysteroskop AD 5mm speziell für 8988.031 Obturator for hysteroscope OD 5mm specially for 8988.031</p>				8988.131
 <p>Arbeitseinsatz für Hysteroskop 21CH mit Auslenk-Hebel und Zulaufhahn, sowie automatisches Ventil für Arbeitskanal, mit Dichtmembran (89.101) Working insert for hysteroscope 21FR with deflection lever, inlet tap and automatic valve for working channel, with sealing membrane (89.101)</p>		7 Charr. / Fr.		8988.231
 <p>Arbeitseinsatz für Hysteroskop 21CH mit Rampe und Zulaufhahn, sowie automatisches Ventil für Arbeitskanal, mit Dichtmembran (89.101) Working insert for hysteroscope 21FR with ramp, inlet tap and automatic valve for working channel, with sealing membrane (89.101)</p>		7 Charr. / Fr.		8988.241

Compact Hysteroscope
3.8 mm, 30°

Kompakt-Hysteroskop
3,8 mm, 30°

				
<p>AUTOCLAVE 134° C / 273° F</p>				
	Schaft / Sheath	Arbeitskanal / Working channel	NL / WL	Typen / Types
 <p>Hysteroskop kpl bestehend aus: Hysteroskop 30° (8986402) und Gummikappe "RIWO", rot (VE=10 ST, 88.01) Hysteroscope bndl consisting of: Hysteroscope 30° (8986402) and rubber cap "RIWO", red (PACK=10 PCS, 88.01)</p>	Ø 3.8 mm	5 Charr. / Fr.	217 mm	89864021
				8986.251
	<p>Handgriff für Hysteroskop Handle for hysteroscope</p>			

5

- Compact and ergonomic system with atraumatic instrument tip
- Exceptional image quality in a smaller design
- Continuous irrigation via separate inlet and outlet system for optimum viewing conditions
- Use of auxiliary instruments up to 5 Fr. via straight working channel

- Außergewöhnliche Bildqualität in einem kleineren Design
- Kompaktes und ergonomisches System mit atraumatischer Instrumentenspitze
- Dauerspülung über getrenntes Zu- und Ablaufsystem gewährleistet optimale Sichtverhältnisse
- Anwendung von Instrumenten bis 5 Charr. über geraden Arbeitskanal

Recommended light cable:

Fiber light cable bndl, Ø 2.5 mm, 2.3 m long
consisting of:

Fiber light cable (80662523), adapter projector-side (8095.07) and adapter endoscope-side (809509) 806625231
(for maximum light transmission)

Empfohlenes Lichtleitkabel:

Fiber Lichtleiter kpl, Ø 2,5 mm, 2,3 m lang
bestehend aus:

Fiber Lichtleiter (80662523), Adapter projektorseitig (8095.07) und Adapter endoskopseitig (809509) 806625231
(für maximale Lichttransmission)

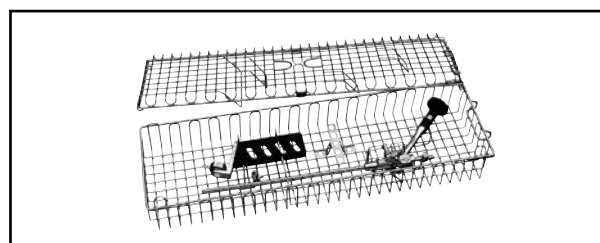

Siebkorb für Hysteroskop 2

mit Kleinteilesieb,

Innenmaße (BxHxT): 451x80x124mm,

Außenmaße (BxHxT): 467x90x132mm 38009

Perforated basket for hysteroscope 2



with small part basket,

inner dimensions (wxhxd): 451x80x124mm,

outer dimensions (wxhxd): 467x90x132mm 38009

Compact Hysteroscope
5 mm, 20°

Kompakt-Hysteroskop
5 mm, 20°

by Grochmal		nach Grochmal		
				
<p>AUTOCLAVE 134° C / 273° F</p>				
	Schaft / Sheath	Arbeitskanal / Working channel	NL / WL	Typen / Types
 Hysteroskop, 20° <i>Hysteroscope, 20°</i>	Ø 5 mm	5 Charr. / Fr.	217 mm	8986.401
Handgriff für Hysteroskop <i>Handle for hysteroscope</i>				8986.251

6

- Compact and ergonomic system
 - small outer dimensions - large-lumen straight working channel
- Brilliant image and high light transmission with the PANOVIEW PLUS telescope and large field of view
- Round profile
 - easy introduction usually without dilatation
 - better seal
- Continuous irrigation via separate inlet and outlet system for optimum viewing conditions
- Use of auxiliary instruments up to 5 Fr.

Recommended light cable:

Fiber light cable bndl, Ø 2.5 mm, 2.3 m long consisting of:

Fiber light cable (80662523), adapter projector-side (8095.07) and adapter endoscope-side (809509) 806625231 (for maximum light transmission)

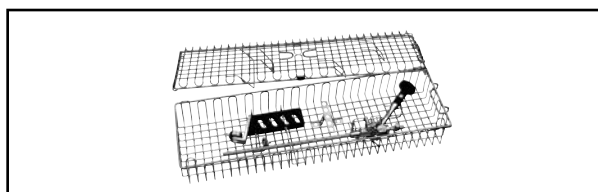

- Kompaktes und ergonomisches System
 - kleiner Außendurchmesser - großlumiger, gerader Arbeitskanal
- Brillante und lichtstarke PANOVIEW Plus-Optik mit großem Bildwinkel
- Rundes Profil
 - leichtes Einführen meist ohne Dilatation
 - bessere Abdichtung
- Dauerspülung über getrenntes Zu- und Ablaufsystem gewährleistet optimale Sichtverhältnisse
- Anwendung von Hilfsinstrumenten bis 5 Charr.

Empfohlenes Lichtleitkabel:

Fiber Lichtleiter kpl, Ø 2,5 mm, 2,3 m lang bestehend aus:

Fiber Lichtleiter (80662523), Adapter projektorseitig (8095.07) und Adapter endoskopseitig (809509) 806625231 (für maximale Lichttransmission)

Siebkorb für Hysteroskop 2 mit Kleinteilesieb,

Innenmaße (BxHxT): 451x80x124mm,

Außenmaße (BxHxT): 467x90x132mm 38009

Perforated basket for hysteroscope 2 with small part basket,

inner dimensions (wxhxd): 451x80x124mm,

outer dimensions (wxhxd): 467x90x132mm 38009





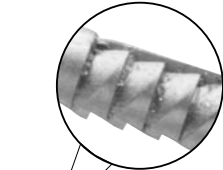
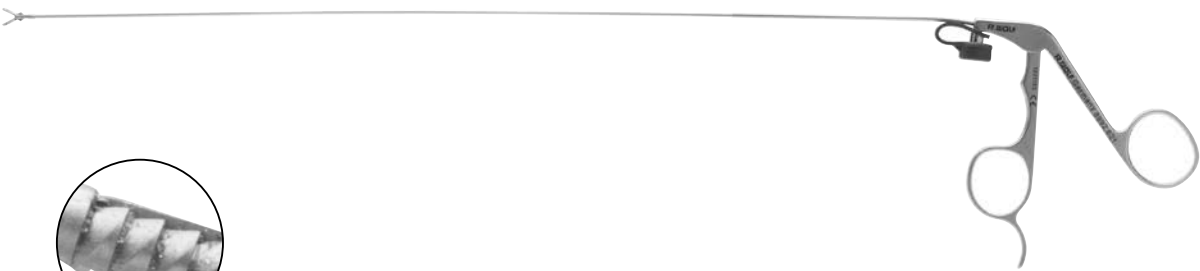

Rigid Forceps 7 Fr.

Starre Zange 7 Charr.

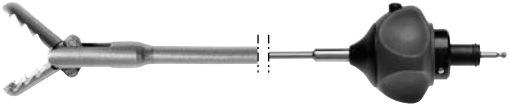
			
<p>Starre Präparierzange, Maulteil innen und außen gerieft und zusätzliche Schneidekante Rigid Preparation forceps, grooved inner and outer surfaces of jaws and additional cutting edge</p>	<p>Charr. / Fr.</p> <p>7</p>	<p>NL / WL</p> <p>371 mm</p>	<p>Type / Type</p> <p>8992.621</p>

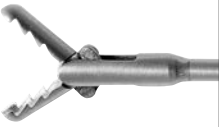
Forceps and Scissors
micro modular system **HySafe**

Zangen und Scheren
Kleinmodulares System **HySafe**



Maulteil mit Schaft / Jaw insert with sheath						Griff mit Überlastschutz Handle with overload protection		Komplett- Instrument <ul style="list-style-type: none"> • Maulteil • Griff Complete instrument <ul style="list-style-type: none"> • Insert with sheath • Handle Typen / Types	
		Einsatz- empfehlung Recommended fields of application	Typen / Types	Charr. / Fr.	NL / WL				
Greifzange kpl mit Hechtmaul			8642.6508	5	340	8083.001		8642.6502	
Grasping forceps bndl with alligator jaws			8992.6308	7	310			8992.6302	
Greifzange kpl, -Löffel Grasping forceps bndl, -spoon			8642.6008	5	340			8642.6002	
Schere kpl Scissors bndl			8642.6818	5	340			8642.6812	
PE-Zange kpl Biopsy forceps bndl			8642.6318	5	340			8642.6312	
Hakenschere kpl Hooked scissors bndl			8992.6408*	7	310			8992.6402*	

* on request

* auf Anfrage



Flexible Forceps 3 Fr.

Flexible Zangen 3 Charr.

			
	Charr. / Fr.	NL / WL	Typen / Types
 Flexible Probe-Exzisionszange <i>Flexible biopsy forceps</i>	3	380 mm	829.131
 Flexible Greifzange <i>Flexible grasping forceps</i>	3	380 mm	828.131

BipoTrode
1.6 mm / 5 Fr. Bipolar Electrode

BipoTrode
1,6 mm / 5 Charr. Bipolar-Elektrode

		
	NL / WL	Typen / Types
 BipoTrode Elektrode bipolar Electrode bipolar	360 mm	823005

- For precise dissection, preparation and coagulation using saline desension solutions, also for use in laparoscopy (e.g. in combination with trocar sleeve 8309.172 with trocar 8309.121)
- Small diameter of 5 Fr. allows use with hysteroscopes
- Made of semiflexible stainless steel it is suitable for use with curved working channels and ideal for use through the straight working channels of the compact R. WOLF hysteroscopes
- Robust and ergonomic handle
- Autoclavable and reusable



- Zur Dissektion, Präparation und Koagulation in der Hysteroskopie, auch in der Laparoskopie einsetzbar (passend z.B. zu Trokarhülse 8309.172 mit Trokar 8309.121)
- Sehr filigrane Abmessungen zur Anwendung durch klassische Hysteroskope mit 5 Charr. Arbeitskanal
- Durch Verwendung semielastischen Stahls sowohl durch gerade als auch durch schräg zulaufende Arbeitskanäle anwendbar
- Stabiler und ergonomischer Handgriff für einfaches Handling
- Autoklavierbar und somit wiederverwendbar

Bipolar-Pinzettenanschlusskabel siehe Seite / *Bipolar tweezers connecting cable see page E 144.*

*Electrodes
monopolar*





Elektroden
monopolar



	Charr. / Fr.	NL / WL	Typen / Types
 Koagulations-Elektrode mono <i>Coagulation electrode mono</i>	6	400 mm	823.06
 Nadel-Elektrode mono <i>Needle electrode mono</i>	5	420 mm	824.05

For Cervix and Uterus

Für Portio und Uterus

		
	NL / WL	Type / Type
 <p>Uterusgreifzange nach Pozzi, zum Anhängen der Portio Uterus grasping forceps by Pozzi, for grasping the cervix</p>	92 mm	8370.25
 <p>Uterusgreifzange nach Gimpelson Uterus grasping forceps by Gimpelson</p>	242 mm	8371.10
 <p>Uterusgreifzange nach Saïrges, Ø 6,5 mm zum Fixieren und Elevieren des Uterus Uterus grasping forceps by Saïrges Ø 6,5 mm for fixation and elevation of the uterus</p>	100 mm	8370.00

11

For Cervix and Uterus

Für Portio und Uterus

<p>for fixation, elevation as well as hydro and chromopertubation of the uterus</p>		<p>zum Fixieren, Elevieren sowie zur Hydro- und Chromopertubation des Uterus</p>	
		<p>NL / WL</p>	<p>Typen / Type</p>
<p>Uteruskatheter nach Sellheim, Ø 4,0 mm Uterine catheter by Sellheim, Ø 4.0 mm</p>		<p>42 mm</p>	<p>8368.00*</p>

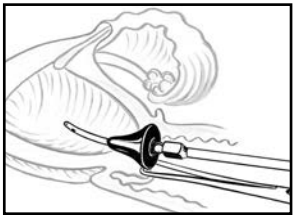
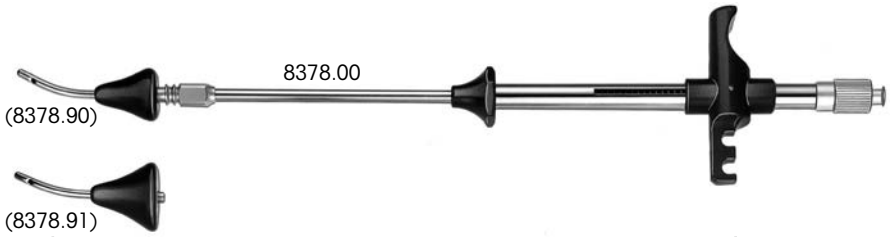
<p>for fixation, elevation as well as hydro and chromopertubation of the uterus</p>		<p>zum Fixieren, Elevieren sowie zur Hydro- und Chromopertubation des Uterus</p>	
<p></p>			
		<p>(8378.90) 8378.00 (8378.91)</p>	<p>NL / WL</p>
<p>Intrauterinsonden kpl bestehend aus: Intrauterinsonde nach Cohen (8378.00) mit federndem Zangenhalter, 1 kleinen (8378.90) und 1 großen (8378.91) Portio-Kegelansatz, Luer-Lock-Schlauchteil (886.00)</p> <p>Intrauterine probes bndl consisting of: Intrauterine probe by Cohen (8378.00) with spring-mounted forceps holder, 1 small (8378.90) and 1 large (8378.91) cervical cone, luer lock tube fitting (886.00)</p>		<p>32 mm</p>	<p>8378001*</p>

* also:
Uterus grasping forceps by Pozzi, WL 92 mm 8370.25

* hierzu:
Uterusgreifzange nach Pozzi, NL 92 mm 8370.25





PRINCESS

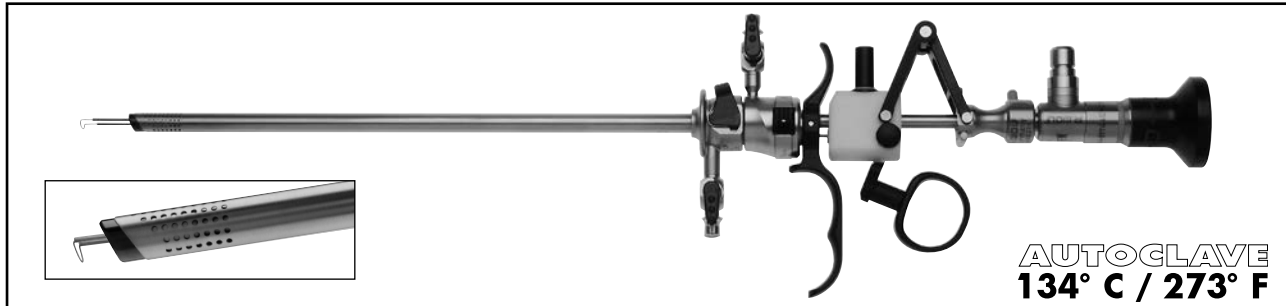

Petit Resectoscope including
E-line & S(a)line System

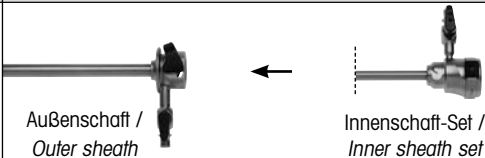
PRINCESS

Petit Resectoscope including
E-line & S(a)line System



Charr., Kennfarbe Fr., colour code	distales Ende distal tip	Schäfte, Innenschaff mit distaler Keramikisolation Sheaths, inner sheath with distal ceramic insulation	Obturator Obturator	Sichtobturator Viewing obturator	Elektroden Electrodes
Schäfte Sheaths		 Außenschaff / Outer sheath ← Innenschaff-Set / Inner sheath set			
7 mm 21 Charr. / Fr. schwarz / black		8653.021	8653.18	865319	siehe Seite see page E 124 / E 125
		8653.018 (19 Charr. / Fr.)			

Arbeits-Element Working element	Griff-Varianten Handle type	schneidend cutting action	Type Type
 Schnitt erfolgt durch Federdruck Spring-assisted cutting action	offen / open	passiv / passive	8653.224
 Schnitt erfolgt gegen Federdruck Manual cutting action with spring-assisted release	offen / open	aktiv / active	8653204

Arbeitseinsatz Working insert	für Hilfsinstrumente auxiliary instruments	Type Type
	bis 7 Charr. up to 7 Fr.	8653284

Optiken Telescopes	Ø	Blickrichtung Viewing direction		
	2.7 mm	12°	8974.412	

Accessories:

Fiber light cable bndl., Ø 2.5 mm, 2.3 m long consisting of:
Fiber light cable (80662523), adapter projector-side (8095.07) and
adapter endoscope-side (809509) 806625231
For sterilising: **Container** 33022

Zubehör:

Fiber Lichtleiter kpl., Ø 2,5 mm, 2,3 m lang bestehend aus:
Fiber Lichtleiter (80662523), Adapter projektorseitig (8095.07) und
Adapter endoskopseitig (809509) 806625231
Zur Aufbereitung: **Behälter** 33022

HF-Anschlusskabel siehe Seite / HF connecting cable see page E 145.







PRINCESS

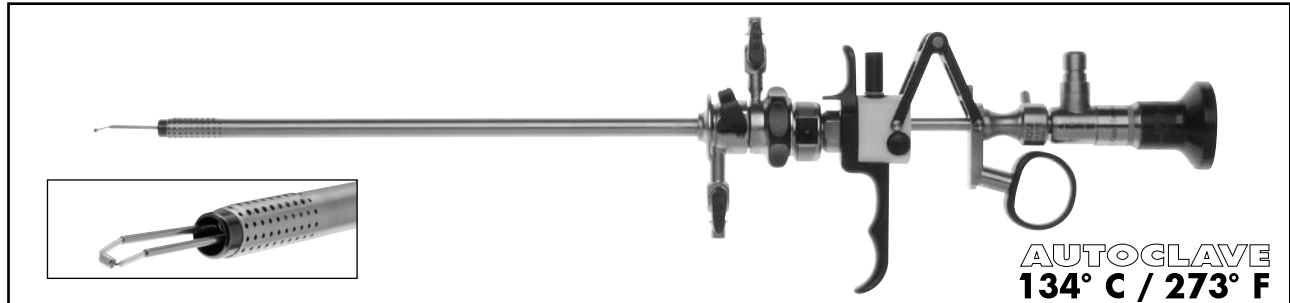

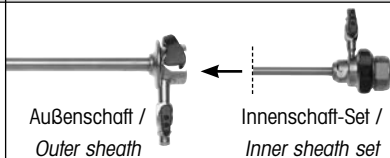
Petit Resectoscope including
E-line & S(a)line System, rotatable

PRINCESS

Petit Resectoscope including
E-line & S(a)line System, rotierbar



Charr., Kennfarbe Fr., colour code	distales Ende distal tip	Schäfte, Innenschaff mit distaler Keramikisolation Sheaths, inner sheath with distal ceramic insulation	Innenschaff-Set Inner sheath set		Obturator Obturator	Sichtobturator Viewing obturator	Elektroden Electrodes	
Schäfte Sheaths			bestehend aus consisting of					
		Außenschaff / Outer sheath	Innenschaff-Set / Inner sheath set	Innenschaff Inner sheath	Drehbares Verbindungsstück Rotatable connector			
7 mm 21 Charr. / Fr. schwarz / black		8653022	8653019 (19 Charr. / Fr.)	86530191	86533643	8653.18	865319	siehe Seite see page E 124 / E 125
8 mm 24,5 Charr. / Fr. grün / green		8655.334	8655.344 (22.5 Charr. / Fr.)	8655.3441	8654.3642	8654.16	-	

Arbeits-Element Working element	Griff-Varianten Handle type	schneidend cutting action	Type Type
 Schnitt erfolgt durch Federdruck Spring-assisted cutting action	offen / open	passiv / passive	8653.224
 Schnitt erfolgt gegen Federdruck Manual cutting action with spring-assisted release	offen / open	aktiv / active	8653204

Arbeitseinsatz Working insert	für Hilfsinstrumente auxiliary instruments	Type Type
	bis 7 Charr. up to 7 Fr.	8653284

Optik Telescopes	Ø	Blickrichtung Viewing direction	
	2.7 mm	12°	8974.412 

Accessories:

Fiber light cable bndI, Ø 2.5 mm, 2.3 m long consisting of:
Fiber light cable (80662523), adapter projector-side (8095.07) and
adapter endoscope-side (809509) 806625231
For sterilising: **Container** 33022

Zubehör:

Fiber Lichtleiter kpl, Ø 2,5 mm, 2,3 m lang bestehend aus:
Fiber Lichtleiter (80662523), Adapter projektorseitig (8095.07) und
Adapter endoskopseitig (809509) 806625231
Zur Aufbereitung: **Behälter** 33022



HF-Anschlusskabel siehe Seite / HF connecting cable see page E 145.

Electrodes

for PRINCESS Resectoscopes,
2.7 mm telescope, 12°

Elektroden

für PRINCESS Resektoskope,
Optik 2,7 mm, 12°

für Dauerspül-Schaft for continuous-irrigation sheath	Bügel Loop		7 mm / 21 Charr. / Fr.	8 mm / 24,5 Charr. / Fr.
Schneide-Elektrode, monopolar Cutting electrode, monopolar 	0,3 mm	Gabel Branches	rot / red	blau / blue
			8653.131	8653.132
Rollen-Elektrode, monopolar Roller electrode, monopolar 	-	Gabel Branches	rot / red	
			8653.02	
Haken-Elektrode, monopolar und bipolar Hook electrode, monopolar and bipolar 	-	Gabel Branches	rot / red	
			865303	
		Stiel Stem	blau / blue	blau / blue

12







AUTOGLAVE
134° C / 273° F

Protective sterilization sleeve
for a maximum of 5 resection or vaporisation electrodes, or urethrotome knives,
outer Ø 20 mm, length 328 mm 8428.901

Sterilisations-Schutzhülse
zur Aufnahme von max. 5 Resektions- oder Vaporisations-Elektroden, oder Urethrotommesser,
Außen-Ø 20 mm, Länge 328 mm 8428.901

Disposable Electrodes
für PRINCESS Resektoskope,
2.7 mm telescope, 12°





Einmalgebrauch-Elektroden
für PRINCESS Resektoskope,
Optik 2,7 mm, 12°

für Dauerspül-Schaft for continuous-irrigation sheath	Bügel Loop		7 mm / 21 Charr. / Fr.	8 mm / 24,5 Charr. / Fr.
Schneide-Elektrode , bipolar, VE= 3 ST, einzeln steril verpackt Cutting electrode , bipolar, PACK= 3 PCS., packed singly, sterile 	0.3 mm	Gabel Branches	transparent / transparent	transparent / transparent
			4653.1313	4653.1323
Rollen-Elektrode , bipolar, VE= 3 ST, einzeln steril verpackt Roller electrode , bipolar, PACK= 3 PCS., packed singly, sterile 	-	Gabel Branches	transparent / transparent	
			4653.023	
BIVAP-Elektrode , bipolar, VE= 3 ST, einzeln steril verpackt BIVAP electrode , bipolar, PACK= 3 PCS., packed singly, sterile 	-	Gabel Branches	blau / blue	blau / blue
			46530213	46530243
Haken-Elektrode , monopolar und bipolar, VE= 3 ST, einzeln steril verpackt Hook electrode , monopolar and bipolar, PACK= 3 PCS., packed singly, sterile 	-	Gabel Branches	transparent / transparent	
			4653033	
		Stiel Stem	blau / blue	

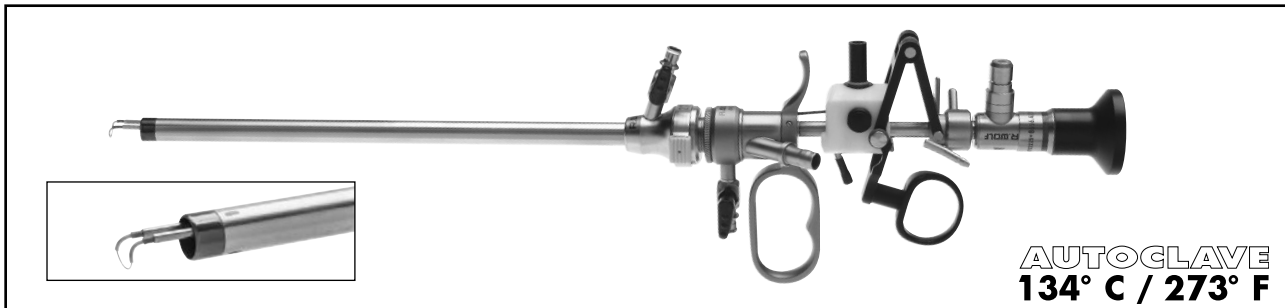
RESECTION MASTER
with automatic chip aspiration

RESECTION MASTER
mit automatischer Chip-Absaugung



Charr., Kennfarbe Fr., colour code	distales Ende distal tip	Dauerspül-Außenschaft, gerade, "E-line" Material: Titan / Edelstahl Continuous-flow outer sheath, straight, "E-line" material: titanium / stainless steel	Obturator Obturator	Elektroden Electrodes
Schaft Sheath				
9 mm 27 Charr. / Fr. schwarz / black		8659.071	8659.175	siehe Seite see page E 127 / E 128

Arbeits-Element, "E-line" Working element, "E-line"	Griff-Varianten Handle type	schneidend cutting action	Type Type
mit integriertem Impulsgeber für Absaugung im Kanal, mit distaler Kunststoff-Isolation with integrated pulse generator control for aspiration, with distal plastic insulation  Schnitt erfolgt durch Federdruck Spring-assisted cutting action	geschlossen / closed	passiv / passive	8659.2351

Optik Telescope	Ø	Blickrichtung Viewing direction	
	3.3 mm	30°	8656.422 

Sterile single use tube set for RESECTION PUMP 2228
consisting of: Control tube, irrigation tube with non-return valve, chip aspiration tube with non-return valve and pump tube
(10 PCS., individually sterile packed) 4170.2228

Recommended light cable:

Fiber light cable bndl, Ø 2.5 mm, 2.3 m long, consisting of:
Fiber light cable (80662523), adapter projector-side (8095.07) and
adapter endoscope-side (809509) 806625231

For sterilising:

Container (wxhxd) 400x60x200mm
inner dimensions (wxhxd): 400x57x200mm,
outer dimensions (BxHxT): 466x77x266mm 33022

Steriles Schlauchset zum Einmalgebrauch an RESECTION PUMP 2228
bestehend aus: Steuerschlauch, Spülschlauch mit Rückschlagventil,
Chip- absaugeschlauch mit Rückschlagventil und Pumpenschlauch
(10 Stück, einzeln steril verpackt) 4170.2228

Empfohlenes Lichtleitkabel:

Fiber Lichtleiter kpl, Ø 2,5 mm, 2,3 m lang, bestehend aus:
Fiber Lichtleiter (80662523), Adapter projektorseitig (8095.07) und
Adapter endoskopseitig (809509) 806625231

Zur Aufbereitung:

Behälter (BxHxT) 400x60x200mm
Innenmaße (BxHxT): 400x57x200mm,
Außenmaße (BxHxT): 466x77x266mm 33022



HF Anschlusskabel siehe Seite / HF connecting cable see page E 143.

Electrodes

for RESECTION MASTER
with automatic chip aspiration

Elektroden

für RESECTION MASTER
mit automatischer Chip-Absaugung

für Dauerspül-Schaft for continuous-irrigation sheath	Bügel Loop		27 Charr. / Fr.
Schneide-Elektrode, monopolar Cutting electrode, monopolar 	0.3 mm	Gabel Branches	rot / red
			8659.161
Vaporisations-Elektrode, tonnenförmig, monopolar Vaporisation electrode, barrel-shaped, monopolar 	-	Gabel Branches	blau / blue
			8659.162
Haken-Elektrode, monopolar und bipolar Hook electrode monopolar and bipolar 	-	Gabel Branches	rot / red
			8659163
		Stiel Stem	rot / red





Protective sterilization sleeve
for a maximum of 5 resection or vaporisation electrodes, or urethrotome knives,
outer Ø 20 mm, length 328 mm 8428.901

Sterilisations-Schutzhülse
zur Aufnahme von max. 5 Resektions- oder Vaporisations-Elektroden, oder Urethrotommesser,
Außen-Ø 20 mm, Länge 328 mm 8428.901

Disposable Electrodes
for RESECTION MASTER
with automatic chip aspiration

Einmalgebrauch-Elektroden
für RESECTION MASTER
mit automatischer Chip-Absaugung

für Dauerspül-Schaft for continuous-irrigation sheath	Bügel Loop		27 Charr. / Fr.
Schneide-Elektrode , bipolar, VE = 3 Stück, einzeln steril verpackt Cutting electrode , bipolar, PACK= 3 PCS., packed singly, sterile 	0.25 mm	Gabel Branches	bleu / azul
			4659.1613
Koagulations-Elektrode , bipolar, VE = 3 Stück, einzeln steril verpackt Coagulation electrode , bipolar, PACK= 3 PCS., packed singly, sterile 	-	Gabel Branches	bleu / azul
			4659.1623
		Stiel Stem	bleu / azul
		Stiel Stem	bleu / azul

RESECTION PUMP 2228

Microprocessor controlled high-power chip aspiration pump with clear LCD display

RESECTION PUMP 2228

microprozessorgesteuerte Hochleistungs-Chip-
absaugpumpe mit übersichtlicher LCD-Anzeige



A new, extremely effective pump unit with integrated pulse aspiration facilitates automatic chip aspiration. The very short aspiration pulse that can be adjusted in 3 levels, restricts the loss of fluid to a minimum, so that collapse of the cavity is effectively prevented.

Ein neues, höchst effektives Pumpenaggregat mit integrierter Impulsabsaugung ermöglicht die automatische Chip-Absaugung. Der extrem kurze Absaugimpuls beschränkt den Flüssigkeitsverlust auf ein (in 3 Stufen vorwählbares) Minimum, wodurch ein Kollabieren des cavums wirkungsvoll verhindert wird.

RESECTION PUMP 2228

suction pump bndl

consisting of:

RESECTION PUMP 2228 (2228.001), bottle holder cpl. (64030.125 and 64031.381), tube set RESECTION PUMP 2228, steril (4170.2228 / PACK=10 PCS), overflow protection/bacteria filter (2228.901 / for single use, PACK=10 PCS), hygiene-filter,steril (2221.901 / PACK=10 PCS), chip collecting container (2228.801) with tube insert (2228.802), secretion container 2000 ml, autoclavable (8170.6551) with lid (8170.6552), sound absorber (35100.115 / PACK= 3 PCS), connection tube (8170.6554) and power cable (2440.03) 2228.0011

also:

Unit cart, 560 x 560 x 800 mm,

4 antistatic castors, 2 with brake 31115.001

RESECTION PUMP 2228

Saugpumpe kpl

bestehend aus:

RESECTION PUMP 2228 (2228.001), Flaschenhalter kpl. (64030.125 und 64031.381), Schlauchset RESECTION PUMP 2228, steril (4170.2228 / VE=10 ST), Überlaufschutz/Bakterienfilter (2228.901 / Einmalartikel, VE=10 ST), Hygienefilter, steril (2221.901 / VE=10 ST), Chip-Auffangbehälter (2228.801) mit Rohreinsatz (2228.802), Sekretbehälter 2 L, autoklavierbar (8170.6551) mit Deckel (8170.6552), Schalldämpfer (35100.115 / VE=3 ST), Verbindungsschlauch (8170.6554) und Netzkabel (2440.03) 2228.0011

hierzu:

Gerätewagen, 560 x 560 x 800 mm,

4 antistatische Rollen, 2 feststellbar 31115.001

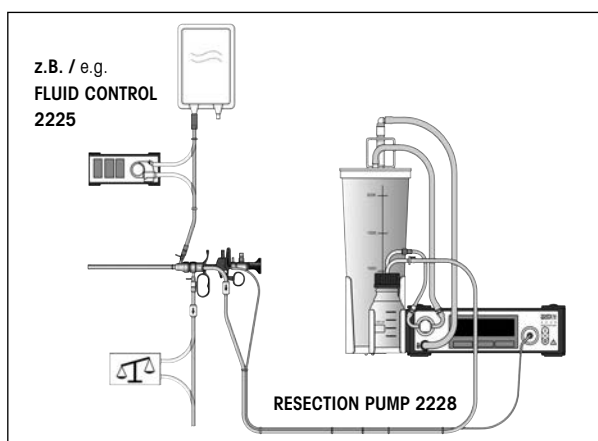

Das RESECTION PUMP System kann mit der Spülpumpe FLUID CONTROL 2225 kombiniert werden.

The RESECTION PUMP System can be combined with Irrigation Pump FLUID CONTROL 2225.



Resectoscope bipolar
 for 4 mm Telescope, 30°, 12°
 with continuous-irrigation double-sheath system
 for resection in saline







Resektoskop bipolar
 für Optik 4 mm, 30°, 12°
 mit Dauerspül-Doppelschaft-System
 zur Resektion in Kochsalzlösung

Arbeitselement, Innenschaft und Optik drehen sich im Außenschaft
 Working elements, inner sheath and telescope are rotating in the outer sheath

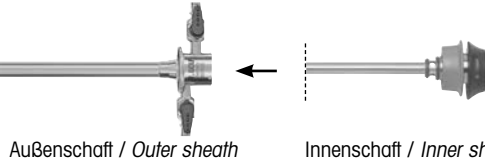

AUTOCLAVE
134° C / 273° F

Charr., Kennfarbe Fr., Colour code	distales Ende distal tip	Schäfte, Innenschaft mit distaler Keramikisolation Sheaths, inner sheath with distal ceramic insulation	Obturator Obturator	Sichtobturator Viewing obturator	Elektroden Electrodes
Schäfte Sheaths		 Außenschaft / Outer sheath Innenschaft / Inner sheath			
22 / 24 Charr. grün / green		8675424	8675322	8673022	8673122
					siehe Seite / see page E 132 / E 133

Arbeits-Elemente siehe Rückseite
Working elements see overleaf



Optiken Telescopes	∅	Blickrichtung Viewing direction	mit gesteigerter Bildgröße und Objektfeld with enlarged image and objective field	
	4 mm	30°	8654.422	
		12°	8654.431	

Recommended light cable:

Fiber light cable bndl, ∅ 2.5 mm, 2.3 m long

consisting of:

Fiber light cable (80662523), adapter projector-side (8095.07) and
 adapter endoscope-side (809509) 806625231

(for maximum light transmission)

Empfohlenes Lichtleitkabel:

Fiber Lichtleiter kpl, ∅ 2,5 mm, 2,3 m lang

bestehend aus:

Fiber Lichtleiter (80662523), Adapter projektorseitig (8095.07) und
 Adapter endoskopseitig (809509) 806625231

(für maximale Lichttransmission)

Bipolar-Anschlusskabel siehe Seite / Bipolar connecting cable see page E 144.

Working Elements

for **Shark** resectoscope bipolar
4 mm telescope, 30°, 12°

Arbeits-Elemente

für **Shark** Resektoskop bipolar
Optik 4 mm, 30°, 12°

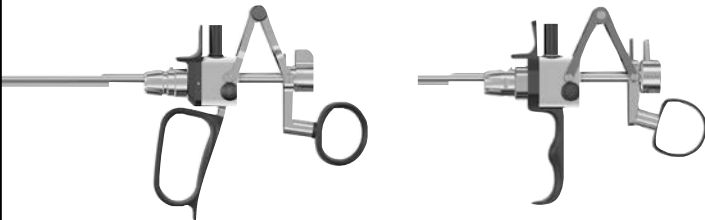
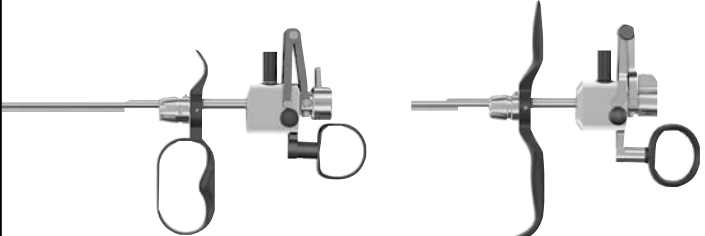
	Griff-Varianten Handle type	schneidend Cutting action	Type Type
 Schnitt erfolgt gegen Federdruck <i>Manual cutting action with spring-assisted release</i>	offen / open	aktiv / active	8680.204
	geschlossen / closed	aktiv / active	8680.205
 Schnitt erfolgt durch Federdruck <i>Spring-assisted cutting action</i>	offen / open	passiv / passive	8680.224
	geschlossen / closed	passiv / passive	8680.225

Thumb ring with large inner diameter..... 15008.159

Daumenring mit größerem Innendurchmesser..... 15008.159

Rubber caps, pack of 5, black 8880
(for sealing the electrode clamping on the working element)



Gummikappe, VE=5 Stück, schwarz 8880
(zum Abdichten der Elektrodenklemmung am Arbeitselement)

Electrodes

for **Shark** resectoscopes bipolar,
4 mm telescope, 30°, 12°

Elektroden

für **Shark** Resektoskope bipolar,
Optik 4 mm, 30°, 12°

für Dauerspül-Schaft for continuous-irrigation sheath	Bügel Loop		22 / 24 Charr. / Fr.
Schneide-Elektrode, rund Cutting electrode, round 	0.3 mm	Gabel Branches	blau / blue
		Stiel Stem	gelb / yellow
Haken-Elektrode Hook electrode 	-	Gabel Branches	blau / blue
		Stiel Stem	gelb / yellow
Koagulations-Elektrode Coagulating electrode 	-	Gabel Branches	blau / blue
		Stiel Stem	gelb / yellow

12



Protective sterilization sleeve

for a maximum of 5 resection or vaporisation electrodes, or urethrotome knives,
outer Ø 20 mm, length 328 mm 8428.901

Sterilisations-Schutzhülse



zur Aufnahme von max. 5 Resektions- oder Vaporisations-Elektroden, oder Urethrotommesser,
Außen-Ø 20 mm, Länge 328 mm 8428.901

Disposable Electrodes

für **Shark** resectoscopes bipolar,
4 mm telescope, 30°, 12°

Einmalgebrauch-Elektroden

für **Shark** Resektoskope bipolar,
Optik 4 mm, 30°, 12°

für Dauerspül-Schaft for continuous-irrigation sheath	Bügel Loop		22 / 24 Charr. / Fr.
Schneide-Elektrode, rund, VE= 3 ST, einzeln steril verpackt Cutting electrode, round, PACK= 3 PCS., packed singly, sterile 	0.25 mm	Gabel Branches	blau / blue
			4622.2533
	0.3 mm	Stiel Stem	blau / blue
			4622.1333
Koagulations-Elektrode, VE= 3 ST, einzeln steril verpackt Coagulating electrode, PACK= 3 PCS., packed singly, sterile 	-	Gabel Branches	blau / blue
			4623.0243
BIVAP-Elektrode, bipolar, VE= 3 ST, einzeln steril verpackt BIVAP electrode, bipolar, PACK= 3 PCS., packed singly, sterile 	-	Stiel Stem	blau / blue
			46300223
		Gabel Branches	blau / blue
			46300223
		Stiel Stem	blau / blue







Resectoscope monopolar
for 4 mm Telescope, 30°, 12°
with continuous-irrigation double-sheath system

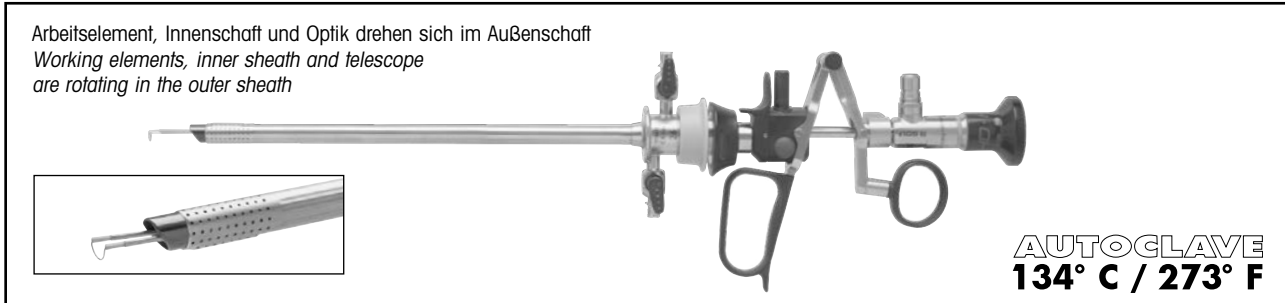

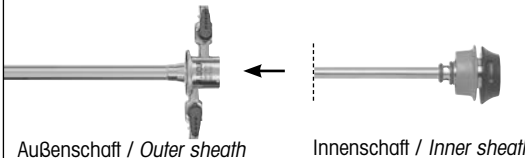
Resektoskop monopolar
für Optik 4 mm, 30°, 12°
mit Dauerspül-Doppelschaft-System



Charr., Kennfarbe <i>Fr., Colour code</i>	distales Ende <i>distal tip</i>	Schäfte, Innenschaft mit distaler Keramikisolation <i>Sheaths, inner sheath with distal ceramic insulation</i>	Obturator <i>Obturator</i>	Sichtobturator <i>Viewing obturator</i>	Elektroden <i>Electrodes</i>
Schäfte <i>Sheaths</i>		 Außenschaft / <i>Outer sheath</i> Innenschaft / <i>Inner sheath</i>			
22 / 24 Charr. grün / <i>green</i>		8675424	8675322	8673022	8673122
					siehe Seite / <i>see page</i> E 136 / E 137



Optiken <i>Telescopes</i>	∅	Blickrichtung <i>Viewing direction</i>	mit gesteigerter Bildgröße und Objektfeld <i>with enlarged image and objective field</i>	
	4 mm	30°	8654.422	
		12°	8654.431	

Recommended light cable:

Fiber light cable bndI, ∅ 2.5 mm, 2.3 m long

consisting of:

Fiber light cable (80662523), adapter projector-side (8095.07) and
adapter endoscope-side (809509) 806625231

(for maximum light transmission)

Empfohlenes Lichtleitkabel:

Fiber Lichtleiter kpl, ∅ 2,5 mm, 2,3 m lang

bestehend aus:

Fiber Lichtleiter (80662523), Adapter projektorseitig (8095.07) und
Adapter endoskopseitig (809509) 806625231

(für maximale Lichttransmission)

HF-Anschlusskabel siehe Seite / *HF connecting cable see page* E 143.

Working Elements

for **Shark** resectoscopes monopolar
4 mm telescope, 30°, 12°

Arbeits-Elemente

für **Shark** Resektoskope monopolar
Optik 4 mm, 30°, 12°

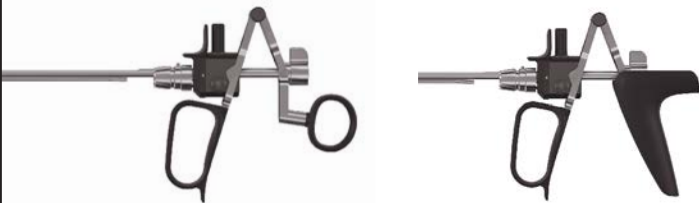
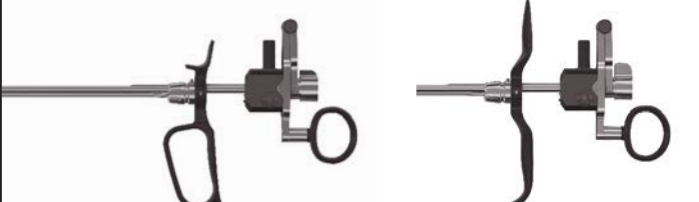
	Griff-Varianten Handle type	schneidend cutting action	Type Type
 Schnitt erfolgt gegen Federdruck Manual cutting action with spring-assisted release	geschlossen / closed	aktiv / active	8674205
	geschlossen mit Komfort-Daumenauflage closed with comfort thumb rest	aktiv / active	8674234
 Schnitt erfolgt durch Federdruck Spring-assisted cutting action	geschlossen / closed	passiv / passive	8674225
	offen / open	passiv / passive	8674224

* with comfort thumb rest

Thumb ring with large inner diameter 15008.159

Rubber caps, pack of 5, red 8874
(for sealing the electrode clamping on the working element)







* mit Komfort-Daumenauflage

Daumenring mit größerem Innendurchmesser 15008.159

Gummikappe, VE=5 Stück, rot 8874
(zum Abdichten der Elektrodenklemmung am Arbeitselement)

Electrodes
for **Shark** resectoscopes monopolar,
4 mm telescope, 12°, 30°

Elektroden
für **Shark** Resektoskope monopolar,
Optik 4 mm, 30°, 12°

für Dauerspül-Schaft for continuous-irrigation sheath	Bügel Loop	Stiel Stem	22 / 24 Charr. / Fr.
Schneide-Elektrode <i>Cutting electrode</i> 	0.35 mm	Gabel Branches	grün / green
		Stiel Stem	86782235 dunkelgrau / dark gray
Koagulations-Elektrode <i>Coagulating electrode</i> 	Rolle Roller	Gabel Branches	grün / green
		Stiel Stem	86782201 dunkelgrau / dark gray
Koagulations-Elektrode <i>Coagulating electrode</i> 	Kugel Ball	Gabel Branches	grün / green
		Stiel Stem	86782202 dunkelgrau / dark gray
Koagulations-Elektrode <i>Coagulating electrode</i> 	Knopf Button	Gabel Branches	grün / green
		Stiel Stem	86782203 dunkelgrau / dark gray
Messer-Elektrode <i>Knife electrode</i> 	-	Gabel Branches	grün / green
		Stiel Stem	86782204 dunkelgrau / dark gray
Haken-Elektrode <i>Hook electrode</i> 	-	Gabel Branches	grün / green
		Stiel Stem	86782205 dunkelgrau / dark gray
Wing-Elektrode <i>Wing electrode</i> 	-	Gabel Branches	grün / green
		Stiel Stem	86782206 dunkelgrau / dark gray

12

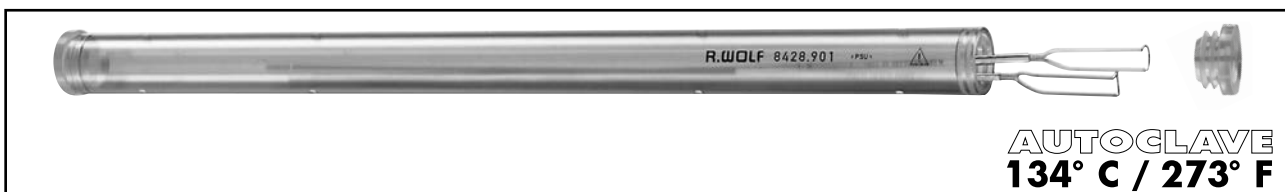

Protective sterilization sleeve for a maximum of
5 resection or vaporisation electrodes, or urethrotome knives,
outer Ø 20 mm, length 328 mm 8428.901







Sterilisations-Schutzhülse zur Aufnahme von
max. 5 Resektions- oder Vaporisations-Elektroden, oder Urethrotommesser,
Außen-Ø 20 mm, Länge 328 mm 8428.901

Disposable Electrodes

for **Shark** resectoscopes monopolar,
4 mm telescope, 12°, 30°

Einmalgebrauch-Elektroden

für **Shark** Resektoskope monopolar,
Optik 4 mm, 30°, 12°

für Dauerspül-Schaft for continuous-irrigation sheath	Bügel Loop	Stiel Stem	Für Schaftgrößen in Charr. / for sheath sizes in Fr. 22/24
Schneide-Elektrode VE= 10 ST, einzeln steril verpackt Cutting electrode PACK= 10 PCS., packed singly, sterile 	Schlinge Loop 0.35 mm	Gabel Branches	grün / green 46782235
		Stiel Stem	transparent / transparent
	Schlinge Loop 0.25 mm	Gabel Branches	grün / green 46782225
		Stiel Stem	transparent / transparent
Koagulations-Elektrode VE= 5 ST, einzeln steril verpackt Coagulating electrode PACK= 5 PCS., packed singly, sterile 	Rolle Roller	Gabel Branches	grün / green 46782201
		Stiel Stem	transparent / transparent
Koagulations-Elektrode VE= 5 ST, einzeln steril verpackt Coagulating electrode PACK= 5 PCS., packed singly, sterile 	Kugel Sphere	Gabel Branches	grün / green 46782202
		Stiel Stem	transparent / transparent
Koagulations-Elektrode VE= 5 ST, einzeln steril verpackt Coagulating electrode PACK= 5 PCS., packed singly, sterile 	Knopf Button	Gabel Branches	grün / green 46782203
		Stiel Stem	transparent / transparent
Messer-Elektrode VE= 5 ST, einzeln steril verpackt Knife electrode PACK= 5 PCS., packed singly, sterile 	Messer Knife	Gabel Branches	grün / green 46782204
		Stiel Stem	transparent / transparent
Haken-Elektrode VE= 5 ST, einzeln steril verpackt Hook electrode PACK= 5 PCS., packed singly, sterile 	Haken Hook	Gabel Branches	grün / green 46782205
		Stiel Stem	transparent / transparent

Flexible Fibre-Hysteroscope 2.5 mm / 7.5 Fr.

Flexibles Fiber-Hysteroskop 2,5 mm / 7,5 Charr.

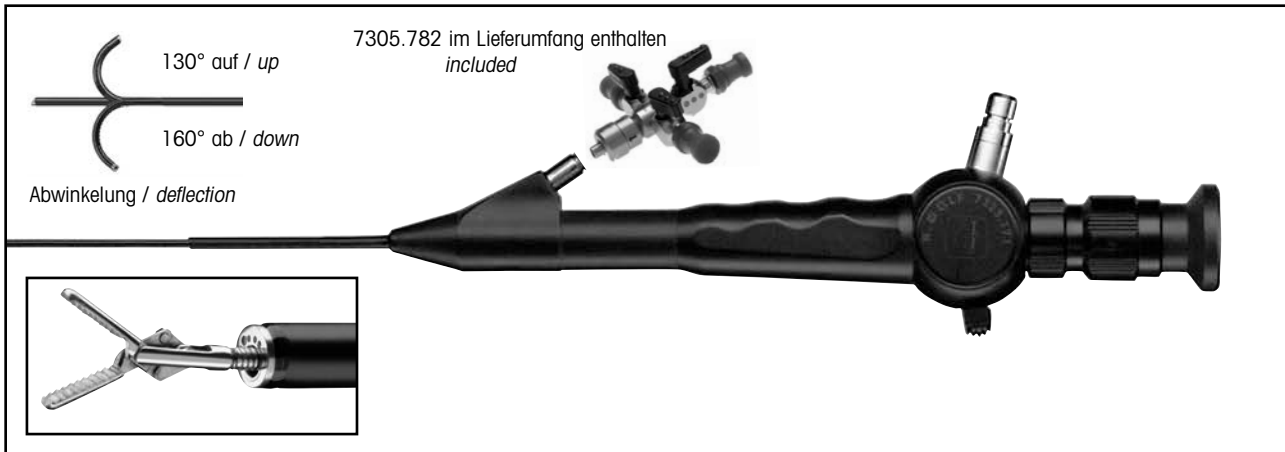

- Optimum ratio between sheath and instrument diameter - 2.5 / 1.2 mm with excellent image quality
- Easy to insert with stepless sheath over the entire working length
- Active deflection of 130° up / 160° down with extra passive deflection
- 0° position of the instrument tip can be clearly felt on the control lever
- Reduced weight and ergonomic design for optimal handling and less strain on the operator
- Immersible and suitable for gas sterilisation
- Optimales Verhältnis von Schaft- zu Sondenkanal-Durchmesser 2,5 / 1,2 mm bei exzellenter Bildqualität
- Gutes Einführungsverhalten durch stufenlosen Schaft auf gesamter Nutzlänge
- Aktive Abwinkelung von 130° auf / 160° ab mit zusätzlicher passiver Abwinkelung
- Spürbare Positionsraste am Steuerhebel zeigt die 0°-Stellung der gestreckten Instrumentenspitze an
- Gewichtsreduzierte Bauweise und ergonomisches Design für optimales Handling und ermüdungsfreies Arbeiten
- Einleg- und gassterilisierbar

	im Set enthaltenes Hysteroskop included in set hysteroscope	Außen-Ø Outer Ø	Sondenkanal Instrument channel	Nutzlänge Working length	Type Type
Fiber-Hysteroskop kpl bestehend aus: Flexibles Fiber-Hysteroskop, Ansatz mit Einführungshahn (7305.782), flexible PE-Zange (7223.60), Dichtigkeitstester (163.903), Gassteril-Ventil (163.904), Reinigungsbürste (7321.911), Koffer Fibre hysteroscope bundle consisting of: flexible fibre hysteroscope, instrument port (7305.782), flexible biopsy forceps (7223.60), water tightness tester (163.903), gas sterilisation valve (163.904), cleaning brush (7321.911), case	7325.122	2.5 mm 7.5 Charr. / Fr.	1.2 mm 3.6 Charr. / Fr.	200 mm	7325.1221

hierzu / also: Fiber Lichtleiter kpl , Ø 1,6 mm bestehend aus: Fiber Lichtleiter (80661618), Adapter projektorseitig (8095.07) und Adapter endoskopseitig (809509) Fiber light cable bndl , Ø 1.6 mm consisting of: Fiber light cable (80661618), adapter projector-side (8095.07) and adapter endoscope-side (809509)				1800 mm	806616181
--	--	--	--	---------	------------------

auf Wunsch / on request: Flexible Fasszange Flexible grasping forceps		1 mm 3 Charr. / Fr.		640 mm	7223.65
---	--	------------------------	--	--------	----------------

13

FLUID CONTROL 2225

Suction and irrigation pump

FLUID CONTROL 2225

Saug- und Spülpumpe



core

Performance

- 1800 ml/min irrigation performance
- 2000 ml/min suction performance
- Continuous irrigation flow
Even in small sized instruments
- NEW: Integrated vacuum function**
Fast exchange of fluid for optimum visualization conditions
- 60% higher irrigation performance compared to previous models

Diagnosis

- Simple instrument selection using touch display
- "Plug-and-Play" by using instrument presets
- Pressure-controlled indication - Optimally adjusted pressure setting
- Optimum irrigation performance also with small- sized instruments
- Endoscopes from other manufacturers
can be used with standard adjustment
- Perioperative permanent maximum power

Resection

- Pressure-controlled indication - Optimally adjusted pressure setting
- Permanent display and monitoring of the fluid deficit
- Acoustic warning signal if the permitted quantity is exceeded

FLUID CONTROL 2225

Irrigation pump for HYS / URO / LAP

Fluid management for irrigation of irrigation fluids

FLUID CONTROL 2225 2225001

FLUID CONTROL 2225, incl. power cable 22250011

Balancing module

fluid management for fluid balancing in combination
with FLUID CONTROL 2225,

mobile stands with integrated load cells and accommodation

for up to 4 irrigation fluid bags 2225023

Leistung

- 1800 ml/min Spüleleistung
- 2000 ml/min Absaugleistung
- Kontinuierlicher Spülstrom
selbst bei dünnlumigen Instrumenten
- NEU: Integrierte Vakuum-Funktion**
Schneller Flüssigkeitsaustausch für optimale Sichtverhältnisse
- 60% höhere Spüleleistung gegenüber Vorgängermodell

Diagnostik

- Einfache Instrumenten-Auswahl über Touch-Display
- "Plug-and-Play" durch Instrumenten-Presets
- Druckgeregelte Indikation - Optimal angepasster Druckwert
- Optimale Spüleleistung auch mit dünnlumigen Instrumenten
- Endoskope anderer Hersteller
können mit Standardeinstellung verwendet werden
- Perioperativ gleichbleibend maximale Leistung

Resektion

- Druckgeregelte Indikation - Optimal angepasster Druckwert
- Permanente Anzeige und Überwachung des Flüssigkeitsdefizits
- Akustisches Warnsignal bei Überschreitung der zulässigen Menge

FLUID CONTROL 2225

Spülpumpe für HYS / URO / LAP

Fluidmanagement zur Irrigation von Spülflüssigkeiten

FLUID CONTROL 2225 2225001

FLUID CONTROL 2225, inkl. Netzkabel 22250011

Bilanzierungsmodul

Fluidmanagement zur Flüssigkeitsbilanzierung in Kombination
mit FLUID CONTROL 2225,

Fahrständer mit integrierten Wiegezellen und Aufnahme

für bis zu 4 Spülflüssigkeitsbeutel 2225023

FLUID CONTROL 2225

Accessories

Irrigation tube set, with piercing connector, 3 m,
with Y-piece, with Luer lock connector,
PACK= 10 PCS, sterile, for single use 4171223

Irrigation tube set, with Care lock, 3 m,
PACK= 10 PCS, sterile, for single use 4171224

Suction-irrigation tube set,
3 m, PACK= 10 PCS, sterile, for single use 4171225

Irrigation tube set, with piercing connector,
with Luer lock connection, incl. 10 replacement membranes,
reusable, 20 x autoclavable 8171223*

Tube set with Y-piece, 5 m
pack of 10, sterile, for single use 4170.901

Vacuum tube,
silicon, reusable, 20x autoclavable 8170.401*

Vacuum tube with filter, 1.7 m 2206207

Tube adapter,
with Luer lock connector, for suction irrigation handle 8385.901
and tube set 8171223 or 8170.223,
reusable 817123*

Drain tube, 3 m
for suction irrigation handle 8385.901
reusable 8171402

Protective filter for gas filtration for single use 4171.121*

Suction container, 3 l
incl. mounting bracket, reusable 8170.981

Suction container, 3 l
PACK= 2 PCS, for single use 2215.971

Wiring accessories

Patch cable, RJ45 SFTP,
cable length 0.5 m 72325378
cable length 1.0 m 72325429
cable length 10 m 72325434
Plastic cap for network socket, PACK= 8 PCS 5592105
Fuse, 5 x 20, 3,15 AT, VE= 2 ST 64268.007
Power cable, cable length 2.0 m 2440.03

* not for U.S. device

FLUID CONTROL 2225

Zubehör

Spülschlauchset mit Anstechdorn, 3 m
mit Y-Stück, mit Luer-Lock-Anschluss,
VE= 10 ST, steril, zum Einmalgebrauch 4171223

Spülschlauchset mit Care-Lock, 3 m
VE= 10 ST, steril, zum Einmalgebrauch 4171224

Saug-Spülschlauchset 3 m
VE= 10 ST, steril, zum Einmalgebrauch 4171225

Spülschlauchset, mit Anstechdorn,
mit Luer-Lock-Anschluss, inkl. 10 Ersatzmembranen,
wiederverwendbar, 20x autoklavierbar 8171223*

Schlauchset mit Y-Stück, 5 m
VE= 10 ST, steril, zum Einmalgebrauch 4170.901

Vakuum-Schlauch,
wiederverwendbar, 20x autoklavierbar 8170.401*

Vakuum-Schlauch mit Filter, 1,7 m 2206207

Schlauchansatz
mit Luer-Lock-Anschluss, für Saug-Spül-Handgriff 8385.901
und Schlauchset 8171223 oder 8170.223,
wiederverwendbar 817123*

Saugschlauch, 3 m
für Saug-Spül-Handgriff 8385.901
wiederverwendbar 8171402

Schutzfilter zur Gasfiltration zum Einmalgebrauch 4171.121*

Saug-Behälter, 3 l
inkl. Halterung, wiederverwendbar 8170.981

Saug-Behälter, 3 l
VE= 2 ST, zum Einmalgebrauch 2215.971

Verkabelungszubehör

Patchkabel, RJ45 SFTP,
Kabellänge 0,5 m 72325378
Kabellänge 1,0 m 72325429
Kabellänge 10 m 72325434
Plastikkappe für Netzwerkbuchse, VE= 8 ST 5592105
Sicherung, 5 x 20, 3,15 AT, VE= 2 ST 64268.007
Netzkabel, Kabellänge 2,0 m 2440.03

* nicht für US-Gerät

Technical Data

FLUID CONTROL 2225

Technische Daten

FLUID CONTROL 2225

FLUID CONTROL 2225	
Netzspannungsbereich (V) <i>Mains voltage range (V)</i>	100 - 240 V~
Versorgungsfrequenz (Hz) <i>Supply frequency range (Hz)</i>	50/60 Hz
Leistungsaufnahme <i>Power consumption</i>	Strom (A) Leistungsaufnahme (VA) <i>Current (A) Power consumption (VA)</i>
100 V / 60 Hz	1,10 A 110 VA
240 V / 50 Hz	0,50 A 118 VA
Schutzklasse (I, II) <i>Protection class (I, II)</i>	I
Betriebsbedingungen <i>Operating conditions</i>	+10 bis/to +40 °C 30 bis 75 % rel. Luftfeuchtigkeit / <i>a</i> 30 to 75 % rel. humidity 70 bis 106 kPa Luftdruck / 70 to 106 kPa air pressure 3000 m max. Einsatzhöhe über NN / 3000 m max. altitude above sea level for device use
Lager- & Transportbedingungen <i>Storage, transport and shipping conditions</i>	-20 bis/to +60 °C 10 bis 90 % rel. Luftfeuchtigkeit / 10 to 90 % rel. humidity 70 bis 106 kPa Luftdruck / 70 to 106 kPa air pressure
Maximaler Saugunterdruck <i>Maximum suction vacuum</i>	-60 kPa
Einstellbare Werte / Bereiche / Adjustable values/ranges	
Sollfluss-Bereich <i>Nominal flow range</i>	Hysteroskopie / <i>Hysteroscopy</i> : 800 ml/min (max. Flow, nicht einstellbar / <i>max. flow, not adjustable</i>) Endourologie / <i>Endourology</i> : 10 - 800 ml/min (max. Flow / <i>max. flow</i>) Laparoskopie / <i>Laparoscopy</i> : 0,1 - 1,8 l/min (max. Flow / <i>max. flow</i>)
Saugleistung <i>Suction power</i>	max. 2 l/min <i>maximum 2 l/min</i>
Ausgangs-Solldruckbereich <i>Starting nominal pressure range</i>	Hysteroskopie / <i>Hysteroscopy</i> : 15 - 200 mmHg Endourologie / <i>Endourology</i> : 15 - 90 mmHg / 20 - 125 cmH ₂ O Laparoskopie / <i>Laparoscopy</i> : 370 mmHg (fest eingestellt / <i>not adjustable</i>)
Druck <i>Pressure</i>	0 - 300 mmHg
Defizit / Verbrauch <i>Deficit / consumption</i>	-9990 bis +9990 ml / 0 bis 99,9 l <i>-9990 to +9990 ml / 0 to 99.9 l</i>
Abmessungen (B x H x T) <i>Maximum dimensions (w x h x d)</i>	300 mm x 157 mm x 436 mm
Gewicht <i>Weight</i>	8,8 kg 8.8 kg

Technical Data

FLUID CONTROL 2225













Technische Daten

FLUID CONTROL 2225

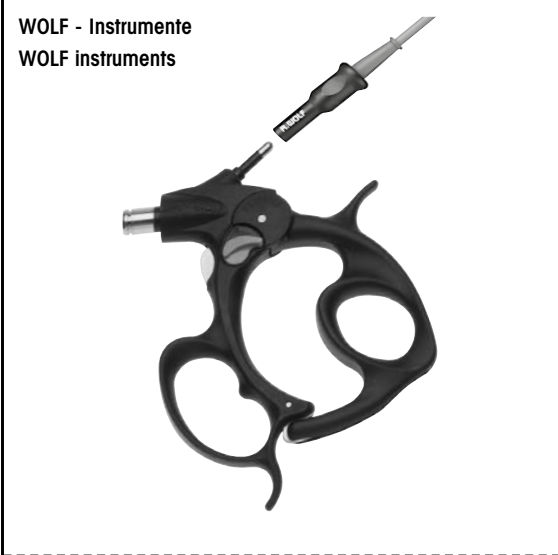
Bilanzierungsmodul / Balancing module	
Betriebsbedingungen <i>Operating conditions</i>	+10 bis/to +40 °C 30 bis 75 % rel. Luftfeuchtigkeit / a 30 to 75 % rel. humidity 70 bis 106 kPa Luftdruck / 70 to 106 kPa air pressure 3000 m max. Einsatzhöhe über NN / 3000 m max. altitude above sea level for device use
Lager- & Transportbedingungen <i>Storage, transport and shipping conditions</i>	-20 bis +60 °C / -20 to +60 10 bis 90 % rel. Luftfeuchtigkeit / 10 to 90 % rel. humidity 70 bis 106 kPa Luftdruck / 70 to 106 kPa air pressure
Maximale Belastung der Behälterwaage <i>Max. load of canister scale</i>	16 kg / 4 Behälter zu jeweils 3 l 16 kg / 4 containers with 3 l each
Maximale Belastung der Beutelwaage <i>Max. load of bag scale</i>	23 kg / 4 Beutel zu jeweils 5 l 23 kg / 4 bags with 5 l each
Abmessungen (B x H x T) <i>Maximum dimensions (w x h x d)</i>	618 mm x 1064 mm x 618 mm















HF Monopolar Connecting Cables

HF-Monopolar Anschlusskabel

Anschluss Instrument <i>Connector for instrument</i>	Anschluss Gerät <i>Connector for unit</i>	Länge <i>Length</i>	Typen <i>Types</i>
<p>WOLF - Resektoskope <i>WOLF resectoscopes</i></p> 	 ERBE (ACC / ICC) / BOWA (EU)	3 m	815.032
		5 m	815.052
	 ERBE (T-Serie) ERBE (T series)	3 m	815.132
		5 m	815.152
	 Martin (m-Version) / Berchtold / Aesculap	3 m	815.031
		5 m	815.051
<p>HF-Elektroden, monopolar <i>Monopolar HF electrodes</i></p> 	 Bovie / Valleylab / Erbe (Int.) / BOWA (Int.)	3 m	815.033
		5 m	815.053
	 BOWA (Int. / EU) Eschmann und andere Geräte mit 4 mm Stecker <i>Eschmann and other devices with 4 mm connectors</i>	3 m	815.034
<p>WOLF - Instrumente <i>WOLF instruments</i></p> 	 ERBE (ACC / ICC) / BOWA (EU)	3 m	8106.032
		5 m	8106.052
	 ERBE (T-Serie) ERBE (T series)	3 m	8106.132
		5 m	8106.152
	 Martin (m-Version) / Berchtold / Aesculap	3 m	8106.031
		5 m	8106.051
<p>HF-Elektroden, monopolar <i>Monopolar HF electrodes</i></p> 	 Bovie / Valleylab / Erbe (Int.) / BOWA (Int.)	3 m	8106.033
		5 m	8106.053
	 BOWA (Int. / EU) Eschmann und andere Geräte mit 4 mm Stecker <i>Eschmann and other devices with 4 mm connectors</i>	3 m	8106.034
		5 m	8106.054



HF Bipolar Connecting Cables

HF-Bipolar Anschlusskabel

Anschluss Instrument <i>Connector for instrument</i>	Anschluss Gerät <i>Connector for unit</i>	Länge <i>Length</i>	Typen <i>Types</i>
 <p>WOLF Bipolar-Zangen <i>WOLF bipolar forceps</i></p>	 ERBE (ACC / ICC / T) / BOWA (EU)	3 m	8108.032
	 Martin (Int.) / 2 pin Valleylab / BOWA (Int.)	5 m	8108.052
	 WOLF / Martin (m-Version) / Berchtold / Aesculap	3 m	8108.033
	 WOLF / Martin (m-Version) / Berchtold / Aesculap	5 m	8108.053
	 WOLF / Martin (m-Version) / Berchtold / Aesculap	3 m	8108.031
	 EMC Dolley	5 m	8108.051
 <p>Bipolar-Pinzetten Anschluss <i>Bipolar tweezers</i></p>	 ERBE (ACC / ICC / T) / BOWA (EU)	3 m	8108.132
	 Martin (Int.) / 2 pin Valleylab / BOWA (Int.)	5 m	8108.152
	 WOLF / Martin (m-Version) / Berchtold / Aesculap	3 m	8108.133
	 WOLF / Martin (m-Version) / Berchtold / Aesculap	5 m	8108.153
	 WOLF / Martin (m-Version) / Berchtold / Aesculap	3 m	8108.131
	 EMC Dolley	5 m	8108.151
		3 m	8108135

HF Connecting Cables
for *S(a)line* resectoscopes

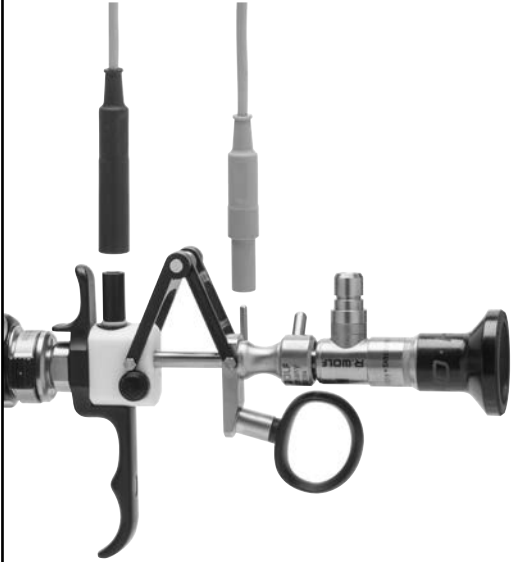
HF Anschlusskabel
für *S(a)line* Resektoskope

Anschluss Instrument Connector for instrument	Anschluss Gerät Connector for unit	Länge Length	Typen Types
<p>WOLF S(a)line-Resektoskope WOLF S(a)line resectoscopes</p> 		3 m	8108.232
	ERBE	5 m	8108.252
		3 m	8108.231
	Martin (m-Version)	5 m	8108.251

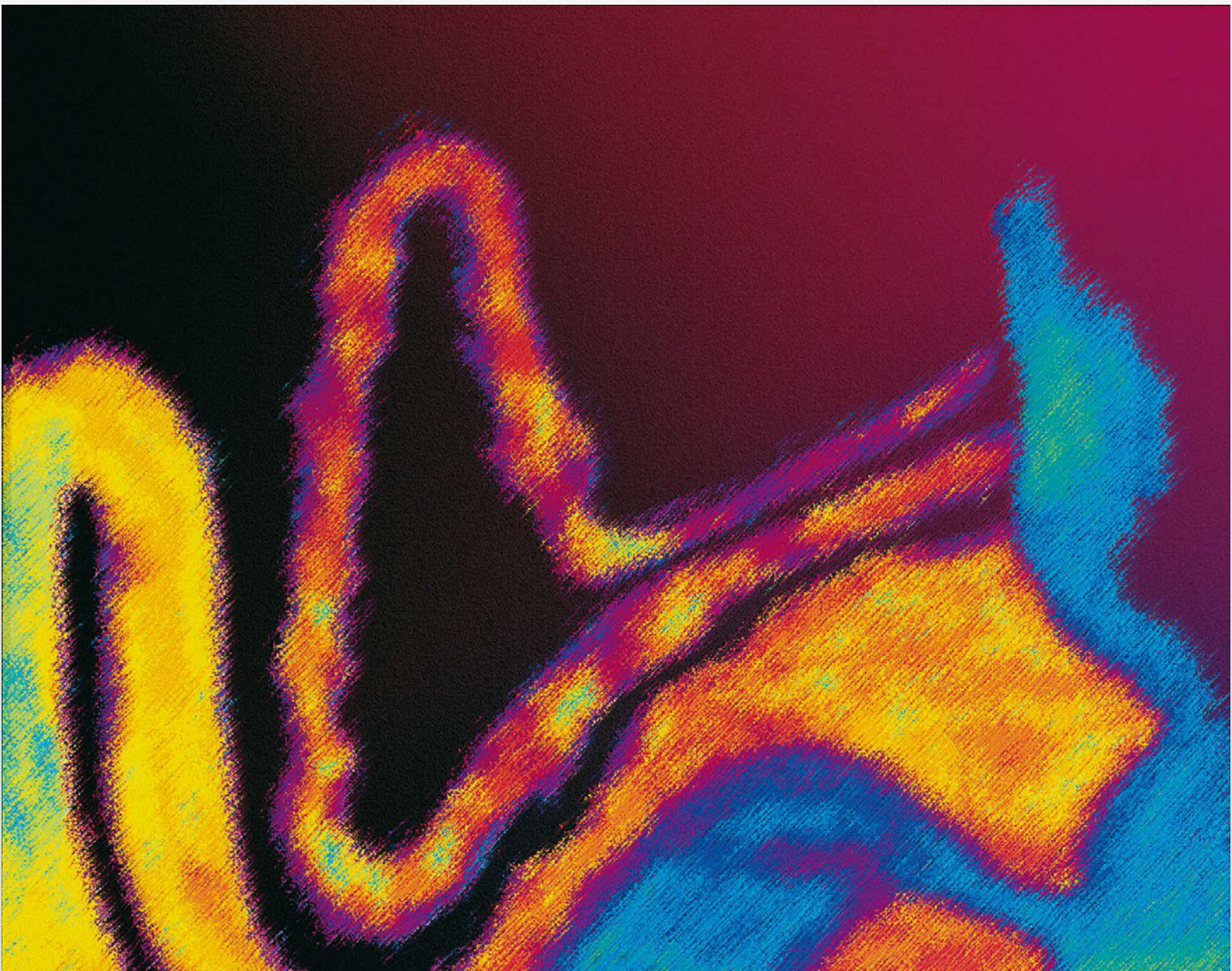

Interdisziplinäre Anwendungen

Cysto-Urethroskopie

Interdisciplinary Applications

Cysto-Urethroscopy

Interdisciplinary Applications

Interdisziplinäre Anwendungen

1

*Cysto-Urethroscope 8650
for Telescope 4 mm, 0°, 5°, 30°, 70° (TVT)*

2

Cystoscope 14, 17 Fr., 25°

3

Set for transurethral Incontinence Therapy

Cysto-Urethroskop 8650
für Optik 4 mm, 0°, 5°, 30°, 70° (TVT)

Cystoskop 14, 17 Charr., 25°

Set zur transurethralen Inkontinenz-Therapie

Cysto-Urethroscope

8650 E-line





for telescope 4 mm, 0°, 12°, 30°, 70°
and adaptors

Cysto-Urethroskop

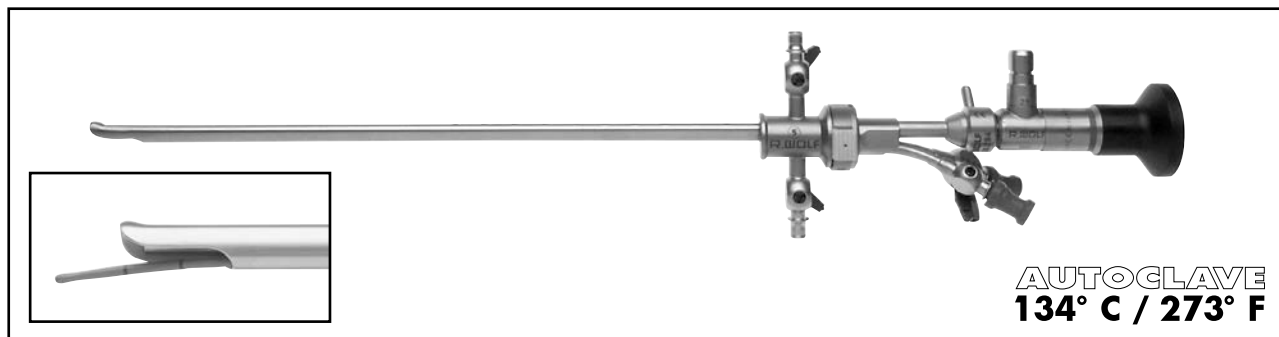
8650 E-line

für Optik 4 mm, 0°, 12°, 30°, 70°
und Ansätze



Schäfte und Obturatoren <i>Sheaths and obturators</i>						Ansätze <i>Adaptors</i>		
								
Schaft inkl. Obturator <i>Sheath incl. obturator</i>	Schaft einzeln <i>Sheath single</i>	Obturator einzeln <i>Obturator single</i>	Charr. <i>Fr.</i>	Kennfarbe <i>Colour code</i>	Durchlass in Charr. <i>Capacity (Fr.)</i>	nur zur Diagnostik <i>only for examination</i>	1 Einführungshahn <i>1 Instrument port</i>	2 Einführungshähne <i>2 Instrument ports</i>
8650.0141	8650.0145	8650.0147	16	gelb <i>yellow</i>	1x5*	8650.254	8650.264	8650.284
8650.0241	8650.0245	8650.0247	17.5	grün <i>green</i>	1x5 oder / or 2x4			
8650.0341	8650.0345	8650.0347	19.5	rot <i>red</i>	1x7 oder / or 2x5			
8650.0441	8650.0445	8650.0447	21	blau <i>blue</i>	1x10 oder / or 2x6			
8650.0541	8650.0545	8650.0547	23	weiß <i>white</i>	1x12 oder / or 2x7			
8650.0641	8650.0645	8650.0647	25	schwarz <i>black</i>	1x15			

* for urethroscopy (cystoscopy for diagnosis only with adaptor 8650.254)

* nur urethroskopisch (cystoskopisch nur zur Diagnostik geeignet über Ansatz 8650.254)

Ø	Blickrichtung <i>Viewing direction</i>	Typen <i>Types</i>	PANOVIEW-Optiken <i>PANOVIEW telescopes</i>
4 mm	0°	8650.414	
	12°	8654.431	
	30°	8654.422	
	70°	8650.415	

Accessories:

Fiber light cable bndl, Ø 2.5 mm, 2.3 m long consisting of:
Fiber light cable (80662523), adapter projector side (8095.07) and
adapter endoscope side (809509) 806625231
Perf. basket for standard telescope 2
Dimensions (l x w x h): 481 x 59 x 54 mm 38016

Zubehör:

Fiber Lichtleiter kpl, Ø 2,5 mm, 2,3 m lang bestehend aus:
bestehend aus: Fiber Lichtleiter (80663523), Adapter projektorseitig
(8095.07) und Adapter endoskopseitig (809509) 806625231
Siebkorb für Standardoptik 2
Abmessungen (L x B x H) 481 x 59 x 54 mm 38016

Cysto-Urethroscope

8650 E-line



for telescope 4 mm, 30°, 70°
and inserts with Albarran deflector

Cysto-Urethroskop

8650 E-line

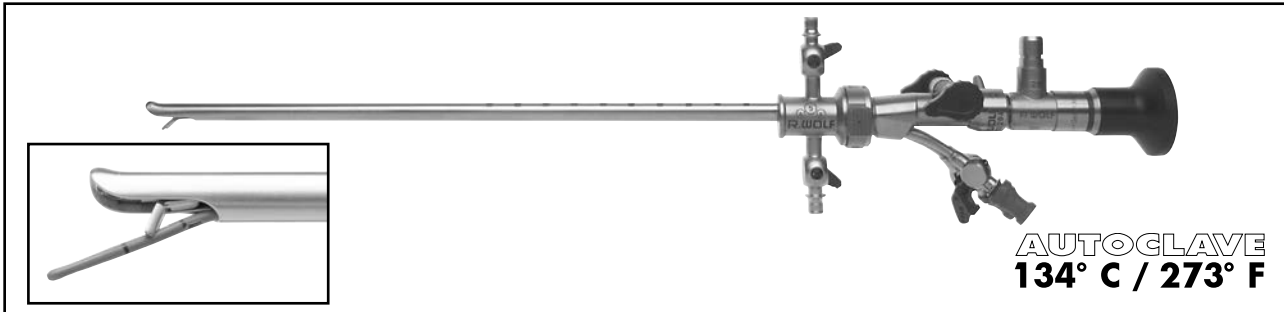
für Optik 4 mm, 30°, 70°
und Einsätze mit Albarran-Hebel



Schäfte und Obturatoren <i>Sheaths and obturators</i>						Einsätze mit Albarran-Hebel <i>Inserts with Albarran deflector</i>	
							
Schaft inkl. Obturator <i>Sheath incl. obturator</i>	Schaft einzeln <i>Sheath single</i>	Obturator einzeln <i>Obturator single</i>	Charr. <i>Fr.</i>	Kennfarbe <i>Colour code</i>	Durchlass in Charr. <i>Capacity (Fr.)</i>	1 Einführungshahn <i>1 Instrument port</i>	2 Einführungshähne <i>2 Instrument ports</i>
8650.0241	8650.0245	8650.0247	17.5	grün green	1x5 oder / or 2x4	8650.214	8650.204
8650.0341	8650.0345	8650.0347	19.5	rot red	1x7 oder / or 2x5		
8650.0441	8650.0445	8650.0447	21	blau blue	1x10 oder / or 2x6		
8650.0541	8650.0545	8650.0547	23	weiß white	1x12 oder / or 2x7		

Ø	Blickrichtung <i>Viewing direction</i>	Typen <i>Types</i>	PANOVIEW-Optiken <i>PANOVIEW telescopes</i>
4 mm	30°	8654.422	
	70°	8650.415	



Accessories:

Fiber light cable bndl, Ø 2.5 mm, 2.3 m long consisting of:
Fiber light cable (80662523), adapter projector side (8095.07) and
adapter endoscope side (809509) 806625231
Perf. basket for standard telescope 2
Dimensions (l x w x h): 481 x 59 x 54 mm 38016

Zubehör:

Fiber Lichtleiter kpl, Ø 2,5 mm, 2,3 m lang bestehend aus:
bestehend aus: Fiber Lichtleiter (80663523), Adapter projektorseitig
(8095.07) und Adapter endoskopseitig (809509) 806625231
Siebkorb für Standardoptik 2
Abmessungen (L x B x H) 481 x 59 x 54 mm 38016

**Atraumatic
Compact Cysto-Urethroscopes
14, 17 Fr., 25°**

**Atraumatische
Kompakt-Cysto-Urethroskope
14, 17 Charr., 25°**

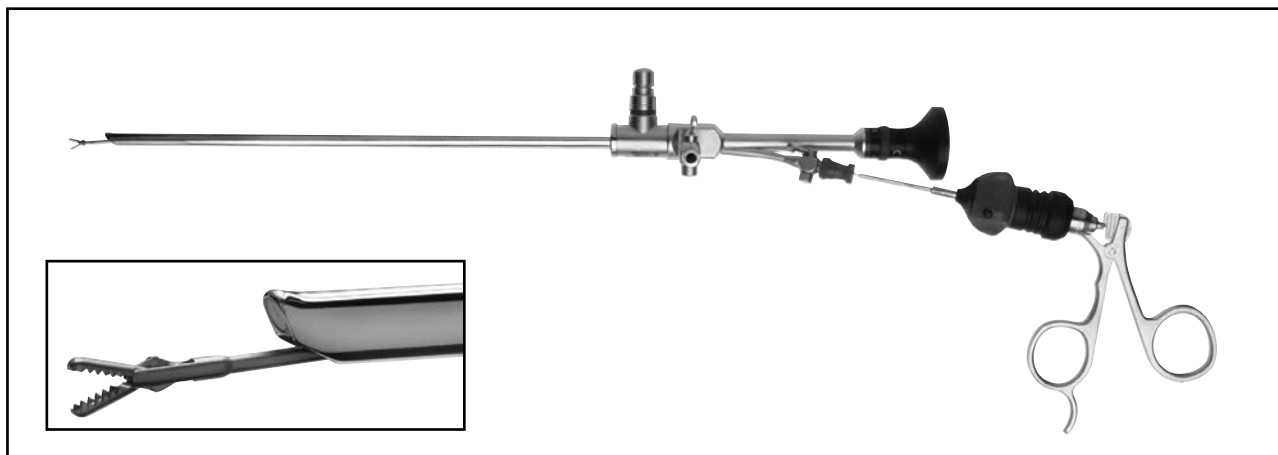

2

For clinique and practice

- Outpatient urethro-cystoscopy, with less stress on the patient
- Biopsy specimens even from the prostate area
- Foreign body extraction (e.g. removal of stents)
- Retrograde manipulation
- Treatment of strictures
- Powerful PANOVIEW PLUS telescope, 25° viewing direction, panoramic field of view, exceptional detail
- Specially shaped atraumatic distal tip
- Compact and sturdy construction

Für Klinik und Praxis

- Patientenfreundliche ambulante Urethro-Cystoskopie
- Biopsieentnahme, auch im Prostatabereich
- Fremdkörper-Extraktion (z.B. Splint-Entfernung)
- Retrograde Manipulationen
- Strikturbehandlung
- Leistungsstarke PANOVIEW PLUS-Optik, 25° Blickrichtung, Panorama-Blickfeld, ausgezeichnete Detail-Erkennbarkeit
- Atraumatisch gestaltetes, distales Ende
- Kompakte und robuste Bauweise

Cystoskop Cystoscope	NL	Charr.	Sondenkanal / Instrument channel für Hilfsinstrumente for accessory instruments		Optik 25° Telescope 25°
	WL	Fr.	Form	Shape	
8642.403	215 mm	14	bis / up to 5 Charr. / Fr.	oval / oval	PANOVIEW PLUS mit gesteigerter Bildgröße und Objektfeld
8645.403	225 mm	17	bis / up to 7 Charr. / Fr.	oval / oval	PANOVIEW PLUS telescope with enlarged image and objective field

Accessories:

Fiber light cable bndl, Ø 2.5 mm, 2.3 m long consisting of:
Fiber light cable (80662523), adapter projector side (8095.07) and
adapter endoscope side (809509) 806625231
Perforated basket for cysto-urethroscope
(L x W x H): 451 x 80 x 64 mm 38013

Zubehör:

Fiber Lichtleiter kpl, Ø 2,5 mm, 2,3 m lang bestehend aus:
bestehend aus: Fiber Lichtleiter (80663523), Adapter projektorseitig
(8095.07) und Adapter endoskopseitig (809509) 806625231
Siebkorb für Cysto-Urethroskop
(L x B x H): 451 x 80 x 64 mm 38013





Hilfsinstrumente siehe Rückseite / Accessory instruments see overleaf

Flexible Accessory Instruments

for cystoscopes 14, 17 Fr., 25°

Flexible Hilfsinstrumente

für Cystoskope 14, 17 Charr., 25°

		NL / WL mm	Charr. Fr.	Type Type
	Flexible Probe-Exzisionszange <i>Flexible biopsy forceps</i>	375	7	829.07
		315	5	829.05
	Flexible Greifzange <i>Flexible grasping forceps</i>	365	7	828.07
		315	5	828.05
	Flexible Schere <i>Flexible scissors</i>	375	7	830.07
	Koagulations-Elektrode mono <i>Coagulating electrode mono</i>	400	6	823.06
		400	5	823.05



2

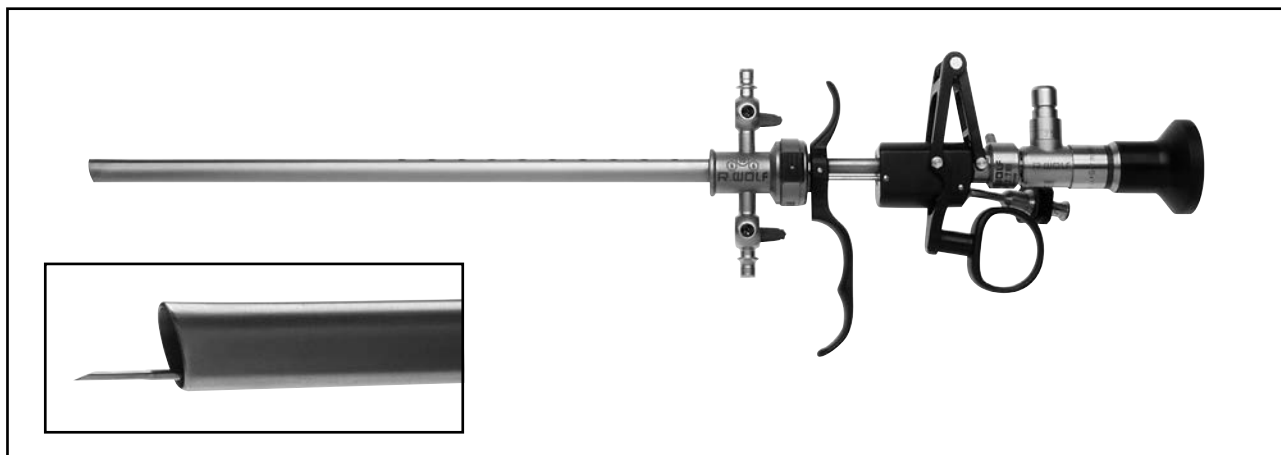

*Set for transurethral
Incontinence Therapy*

Set zur transurethralen
Inkontinenz-Therapie

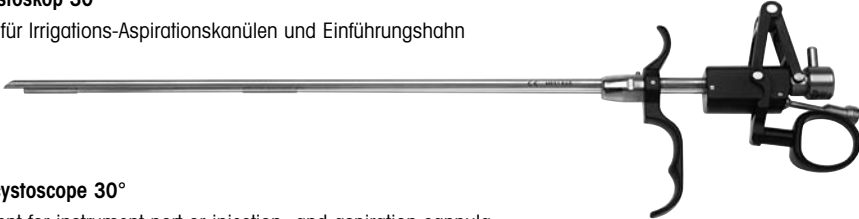

3

		Type Type
<p>Arbeitselement für Cystoskop 30° mit drehbarem Ansatz für Irrigations-Aspirationskanülen und Einführungshahn</p> 		8652.781
<p>Working element for cystoscope 30° with rotatable attachment for instrument port or injection- and aspiration cannula</p>		
<p>Einführungshahn GL 31mm, Durchlass für Instrumente bis 4Charr.</p> <p>Instrument port TL 31mm, capacity for instruments up to 4Fr.</p> 		8652.788
<p>Schaft für Cystoskop mit Obturator Durchlass für Instrumente bis 10 Charr. oder 2x6 Charr.</p> <p>Instrument port with obturator capacity for instruments up to 10 Fr. or 2x6 Fr.</p> 		8652.0441

Optiken Telescopes	Ø	Blickrichtung Viewing direction	mit gesteigerter Bildgröße und Objektivfeld with enlarged image and objective field	
	4 mm	30°	8654.422	 

Accessories:

Fiber light cable bndl, Ø 2.5 mm, 2.3 m long consisting of:
Fiber light cable (80662523), adapter projector side (8095.07) and
adapter endoscope side (809509) 806625231
Perf. basket for standard telescope 2
Dimensions (l x w x h): 481 x 59 x 54 mm 38016

Zubehör:

Fiber Lichtleiter kpl, Ø 2,5 mm, 2,3 m lang bestehend aus:
bestehend aus: Fiber Lichtleiter (80663523), Adapter projektorseitig
(8095.07) und Adapter endoskopseitig (809509) 806625231
Siebkorb für Standardoptik 2
Abmessungen (L x B x H) 481 x 59 x 54 mm 38016

